



# SCHNEIDER

*equipment for professionals*



PROFESSIONELLE PRODUKTE  
Für Bäckerei, Konditorei, Hotellerie und Gastronomie

48

PROFESSIONAL PRODUCTS  
For bakery, confectionery, hotels and gastronomy

Food is  
our passion

Non-Food  
our solution



## Equipment for professionals

Die Schneider GmbH zeichnet sich in allen Produktbereichen als leistungsfähiger und qualitätsbewusster Hersteller, Lieferant und Partner aus. Seit 1977 in Albershausen bei Stuttgart ansässig, liefert das Familienunternehmen qualitativ hochwertige und herausragende Produkte ins In- und Ausland.

Eine konsequente Entwicklung unserer Produkte, die große Auswahl und unsere Kundenorientierung zeichnen uns seit fast 50 Jahren aus.

## Equipment for professionals

Schneider GmbH stands out as an efficient and quality-conscious manufacturer, supplier and partner in all product areas. Based in Albershausen near Stuttgart in the south of Germany, since 1977 the family-owned company supplies high-quality and outstanding products all over the world.

The consistent development of our products, the large selection and our customer orientation have characterized us for almost 50 years.





## Unsere Produktwelten

- Ein großes und umfangreiches Sortiment an Non-Food Fachgeräten für den täglichen Einsatz in Bäckereien, Konditoreien, Gastronomie und Küchen
- Notizblöcke als optimaler Werbeträger



## Our product lines

- A large and comprehensive range of non-food utensils and appliances for daily use in bakeries, confectioneries, restaurants and kitchens
- Notepads as the perfect advertising product

## Qualität aus Leidenschaft

Unsere erstklassige Qualität zeichnet uns seit Jahrzehnten aus. Weltweit namhafte Unternehmen, 5-Sterne-Hotels, ebenso wie der „Bäcker um die Ecke“ arbeiten täglich mit unseren Produkten.

Die imponierende Stärke der Schneider GmbH ist die umfangreiche Produktpalette – eben alles aus einer Hand! Dies gilt nicht nur für unsere Katalogartikel, sondern auch für spezielle Sonderanfertigungen, welche nach Kundenwunsch entwickelt und hergestellt werden.

Alle Prozesse im Unternehmen werden regelmäßig überprüft – seit Jahren schon sind wir ein gemäß ISO 9001:2015 zertifiziertes Unternehmen. Das ist unsere Verpflichtung zu zuverlässigen, nachhaltigen Prozessen und hochwertigen Produkten.

## A passion for quality

Our first-class quality has set us apart for decades. Renowned companies around the world, 5-star hotels and the “baker around the corner” are using our products daily. The impressive strength of Schneider GmbH is its extensive product range – you get everything from a single source! This applies not only to our catalog articles, but also to special custom-made products, which are developed and produced according to customer requirements.

All processes in the company are regularly reviewed – we have been an ISO 9001:2015 certified company for many years. This is our commitment to reliable, sustainable processes and high quality products.

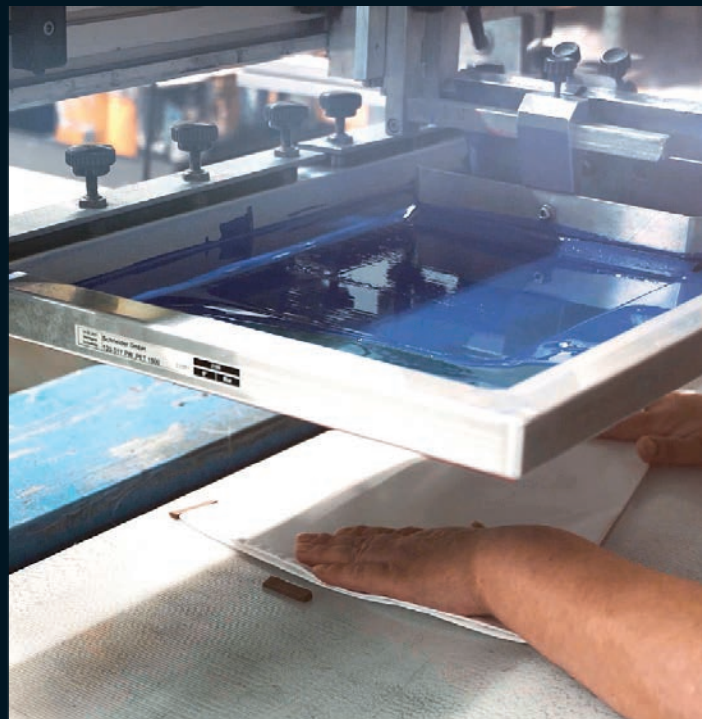
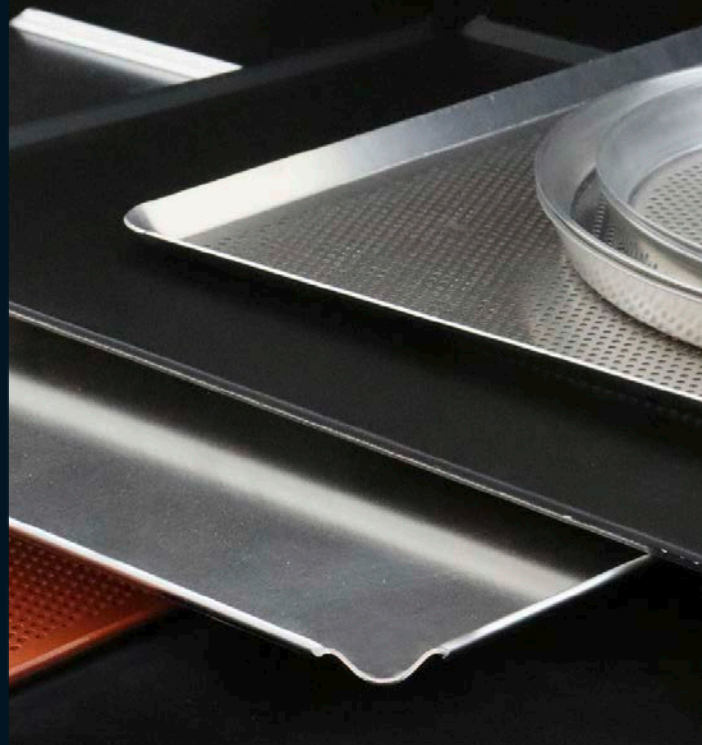



## Service und Kundenähe

Bestmöglicher Service für unsere Kunden und eine rasche Lieferung aller Aufträge zählen zu unseren wichtigsten Prämissen. Kundennähe ist ein essenzieller Faktor. Deshalb finden Sie uns auch auf vielen wichtigen Fachmessen im In- und Ausland. Dort können wir Interessenten und unsere Kunden persönlich beraten und die Qualitätsvorteile der Schneider-Produkte erläutern.

## Customer service

The best possible service for our customers and a fast delivery time for all orders are among our most important premises. Customer proximity is an essential factor. That is why you will find us at many important trade fairs in Germany and around the world. A personal advice to our customers and is very important for us.

## Nachhaltigkeit

Unsere erfolgreichen Produktentwicklungen basieren auf langjähriger Erfahrung, zuverlässigen Leistungen und kundenorientierten Lösungen. Heute sind wir stolz darauf, ein weltweit führender Anbieter zu sein. Unsere Produkte ermöglichen es unseren weltweiten Kunden aus unterschiedlichsten Branchen, energieeffizienter zu wirtschaften, wertvolle Ressourcen zu schonen und gleichzeitig unsere langlebigen Produkte zu nutzen.

Wir sind überzeugt, dass wir durch unser Engagement für Nachhaltigkeit, soziale Verantwortung und starke Governance einen entscheidenden Beitrag zur Gestaltung einer nachhaltigen Wirtschaft leisten können.



## Sustainability

Our successful product developments are based on many years of experience, reliable performance and customer-oriented solutions. Today, we are proud to be a leading global supplier. Our products enable our global customers from a wide range of industries to operate more energy-efficiently, conserve valuable resources and at the same time use our durable products.

We are convinced that we can make a decisive contribution to achieving a sustainable economy through our commitment to sustainability, social responsibility and strong governance.





## Hochwertige Verpackung für Ihren Erfolg

Zahlreiche Produkte werden standardmäßig hochwertig und verkaufsfördernd verpackt – eine optimale Warenpräsentation garantiert für Ihren Erfolg am Verkaufsregal.

## High-quality packaging for your success

Numerous products are packaged in high-quality, sales-promoting packaging as standard – the optimum product presentation guarantees success sales at the displays in your shop.

**Nutzen Sie unser Know-how und unsere Leistungsfähigkeit für Ihre Werbung!**

Ihr Name – Ihr Logo – Ihr Corporate Identity!

Wir bringen Ihre Marke zu Ihren Kunden. Eine Vielzahl unserer Qualitätsprodukte eignen sich perfekt als Werbeträger. Nahezu jede Gestaltungsmöglichkeit auf unterschiedlichen Materialien können wir umsetzen. Auf modernen und leistungsfähigen Maschinen können die unterschiedlichsten Materialien durch Laser, Prägung, Ätzung oder Druck werbewirksam gestaltet werden. Somit können wir Ihrem Marketing-Gedanken Rechnung tragen und sind der richtige Partner für Ihre Werbeprodukte.

**Take advantage of our expertise and performance for your advertising!**

Your name – your logo – your corporate identity!

We bring your brand to your customers. Many of our products are perfect to be used for advertising and promotional purposes. Using modern and efficient technologies, we can implement almost any design options on different products and materials with lasers, embossing, etching or printing. Therefore we can take your marketing ideas into account and are the right partner for your promotional products.





	<b>Inhalt   Content</b>	3	
	<b>Stichwortsuche   Alphabetical index</b>	4 – 11	
	<b>Transport &amp; Lagerung   Transportation &amp; Storage</b> Trasporto e Stoccaggio   Transporte y almacenamiento	12 – 39	<b>1</b>
	<b>Backen   Baking</b> Cottura   Cocer	40 – 57	<b>2</b>
	<b>Backformen   Baking moulds</b> Stampi   Moldes	58 – 69	<b>3</b>
	<b>Silikon-Backformen   Silicone baking moulds</b> Stampi in silicone   Moldes en silicona	70 – 81	<b>4</b>
	<b>Ausstecher   Cutters</b> Tagliapasta   Cortapastas	82 – 99	<b>5</b>
	<b>Fachgeräte   Utensils</b> Utensili   Utensilios	100 – 155	<b>6</b>
	<b>Thermometer   Thermometers</b> Termometri   Termómetros	156 – 161	<b>7</b>
	<b>Arbeitsschutz   Protection</b> Protezione   Protección	162 – 167	<b>8</b>
	<b>Präsentieren   Presentation</b> Presentazione   Presentación	168 – 197	<b>9</b>
	<b>Dekorieren   Decoration</b> Decorazioni   Decoración	198 – 221	<b>10</b>
	<b>Eis   Ice cream</b> Gelato   Helado	222 – 227	<b>11</b>
	<b>Schokolade   Chocolate</b> Cioccolato   Chocolate	228 – 261	<b>12</b>
	<b>Gebäckfüller &amp; Dosierspender   Cream injectors &amp; Dosing dispensers</b> Riempitrici & Dosatore   Dosificadoras	262 – 285	<b>13</b>
	<b>Küchenzubehör   Kitchen Equipment</b> Accessori da Cucina   Accesorios de Cocina	286 – 339	<b>14</b>
	<b>Pizzazubehör   Pizza equipment</b> Accessori per pizza   Accesorios para pizza	340 – 349	<b>15</b>
	<b>Messer &amp; Zubehör   Knives &amp; Accessories</b> Coltelleria & Accessori   Cuchilleria & Accesorios	350 – 373	<b>16</b>
	<b>SB-Displays   SB-Displays</b>	374 – 375	
	<b>Artikelnummern-Index   Item number index</b>	376 – 387	
	<b>Materialeigenschaften   Material characteristics</b>	388 – 393	

## D STICHWORTREGISTER

Artikel	Seite	Artikel	Seite	Artikel	Seite
<b>A</b>					
ABDECKHAUBEN	183	BACKTRENNPAPIERE "RONDEN" UND "RINGREIN"	49	DONUTS-SILIKONFORM	75,79
ABREISSGERÄTE	52, 339	BAGUETTEBLECHE	48	DOSENÖFFNER	330
ABROLLGERÄT	53	BAUMWOLLHANDSCHUHE	165	DOSIERFLASCHE	128
ABSTECHER	103, 104, 106	BEHÄLTERWAGEN	39	DOSIERGERÄT "PRALINENFIX"	229
ABTROPFSTÄNDER	373	BERLINER TÜLLE	211	DOSIERMASCHINE "EDHARD"	264–266
ABZIEHSTAHL	369	BISKUIT-SILIKONFORM	72, 78	DOSIERSYSTEM	277
AIRBRUSH KOMPRESSOR	213	BLECHANFASSER	165	DREIECK-AUSSTECHEWALZEN	109
ALLZWECKZANGEN	193	BRATENTÖPFE	305	DRUCKKNOPF	
APFELAUSSTECHER	329	BRATPFANNEN	303	DOSIERSPENDER	278, 279, 282, 283
APFELSCHÄLMASCHINE	155	BREZEL-SCHNEIDE-SET	360	DRUCKPUMPENZERSTÄUBER	129, 305
APFELTEILER	329	BREZELSCHIESSER	138	DRÜCKSIEB	135
ARBEITSSCHÜRZEN	166	BREZELSTÄNDER	192	<b>E</b>	
AUFSATZRAHMEN	16, 25	BRIOCHEFORMEN	63	ECLAIRS-SILIKONFORM	79
AUFSATZ "HOT & COLD"	21, 25	BRIOCHE-SILIKONFORM	71, 77	EIERSTÜCKLER / EIERTEILER	328
AUFSCHNITTMESSER	356, 358	BROTDRÜCKER	119	EIMER	31
AUSBACKSCHIESSER	138, 139	BROTFORMEN	66, 116–118	EINHANDSIEB	135
AUSBEINMESSER	366, 368	BROTMESSER	356, 358	EINSTECKKARTEN	16, 23
AUSGLEICHSVORRICHTUNG	271	BROTSTREICHER	112	EINWEGSPRITZBEUTEL	204–207
AUSKÜHLPLATTEN	346	BRÖTCHENDRÜCKER	119	EISBEHÄLTER	224
AUSLAGESCHALEN	173	BRÖTCHENMESSER	359	EISDIPPER	223
AUSLAGETABLETTS	169–177	BÄCKER-KLINGE	359	EISPORTIONIERER	223
AUSSTECHER-SÄTZE	82–99	BÄCKERMESSER	350, 355	EISSCHALEN LÖFFELFLÖTE / LÖFFELBEHÄLTER	225
AUSSTECHER	82–99	<b>C</b>		EISSPACHTELN	222
AUSSTECHEMATTEN	92, 93	CANNOLI	152	EISTÜTENHALTER	226, 227
AUSSTELLBLECHE	176,177	CATERING-EINSCHUB	16	EIWEISS-SCHÜSSELN	131
<b>B</b>					
BACK-TRENNSPRAY	54, 296	CHEF 9000	297	ELEKTRONISCHER TIMER	161
BACK- / KONVEKTOMATEN- BLECHE	300, 301	CREME-FORMEN	326	ENGHALSFLASCHE	128
BACKBLECHE	41–43	CREPES-EISEN	337	EPP-BOXEN	15–27
BACKBLECHMESSER	355	CREPES-SCHIEBER	337	ERSATZ-SCHNEIDEBRETT	372
BACKBLECHVORSETZER	47	CREPES-WENDER	337	ERSATZDECKEL TOP-BOX GN 1/2	19
BACKFORMEN AUS SILKON	71–81	<b>D</b>		ERSATZDECKEL TOP-BOX ICE	25
BACKFORMEN AUS PAPIER	57	DARIOLFORMEN	326	ERSATZDECKEL – 40 x 60	20
BACKHANDSCHUHE LEDER	164,165	DECKEL FÜR EISBEHÄLTER	224	ERSATZDECKEL –	
BACKHANDSCHUHE SILIKON	163, 323	DECKEL FÜR PIZZABALLENBOX	33, 344	PIZZA	26, 27, 348, 349
BACKHANDSCHUHE "PREMIUM"	162	DECKEL FÜR SCHÜSSELN	122, 316	ETAGEN-TORTENSTÄNDER	187–189
BACKHANDSCHUHE "STANDARD"	163	DECKEL FÜR STAPELBEHÄLTER	33	<b>F</b>	
BACKHANDSCHUHE NEOPREN	163, 323	DECKEL FÜR TEIGWANNEN	33, 123	FAHRGESTELLE	17,18, 21–23, 32
BACKLINEALE	149	DECKEL FÜR TÖPFE UND PFANNEN	305	FAHRGESTELL FÜR BACKTRENNPAPIER	52
BACKMATTEN	54	DEKOR-AUSSTECHER	82–99	FAHRGESTELL FÜR KÜBEL	32
BACKOFENBESEN	113	DEKOR-SPRITZBEUTEL	200,201,202	FETTPAPIERHALTER	184
BACKPALETTEN	337, 353	DEKOR-TÜLLEN	208–221	FILIERMESSER	367
BACKRAHMEN, VERSTELLBAR	145	DEKORIERPLATTEN	181	FLACHBESEN	120, 320
BACKRAHMEN "HERZ"	143	DESSERT- UND TORTENRINGE	140, 141, 326, 327	FLASCHEN- UND DOSENÖFFNER	330
BACKTRENNFOLIE	53	DESSERTTRINGE	140, 141, 144, 146, 327	FLASCHENWÄRMER	276
BACKTRENNPAPIERE	51, 301	DONUT-AUSSTECHER	87	FLEISCHGABEL	310
				FLEISCHTÖPFE	304
				FLORENTINERRING	141

## D STICHWORTREGISTER

Artikel	Seite	Artikel	Seite	Artikel	Seite
FLORENTINER-SILIKONFORM	73, 74, 77, 78	GYROS-MESSER	365	KUCHENBLECHMESSER	351, 352
FOLIEN-ABREISS-VORRICHTUNG	338, 339	GÄRKÖRBE	116–118	KUCHENPALETTEN	358
FONDANTTRICHTER / SAUCENPORTIONIERER	297	GÄRTÜCHER	118	KUNSTSTOFF-BAND – TORTEN	185
FRANKFURTER KRANZFORM	59	<b>H</b>		KUPPLUNGSSTÜCK FÜR TRICHTER	267
FRANZÖSISCHE TÜLLEN	210	HACCP MARKIERUNGSClips	289, 291	KUVERTÜRE- / SCHOKOLADEABSTECHER	233
FRISCHHALTEFOLIE	338	HANDBÜRSTE FÜR GÄRKÖRBE	118	KÄSETORTENFORM	60
FRITTIERSCHAUFEL	308	HANDENTSTEINER	155	KÖNIGSKUCHENFORM	61, 69
FRONT-BOX GN 1/1	18	HANDSCHIESSER	139, 346	KÖNIGSKUCHENPLATTEN	175
FRONT-BOX – 40 x 60	22	HANDSCHLAGKESSEL	127	KÖNIGSKUCHEN-SILIKONFORM	81
FRÜCHTE ABLAUF-SET	122, 317	HAUSHALTS-SPRITZBEUTEL	202	KÜBEL	32
FRÜHSTÜCKSMESSER	360	HEBEL-DOSIERSPENDER / TEIGDOSIERER – STANDGERÄT	336	KÜCHENMESSER	351, 355, 367
FUSSBALLFELD-BACKFORM	64	HEBEL-DOSIERSPENDER MIT DONUT-AUFSATZ	275	KÜCHENSIEBE	311, 312
FUSS FÜR EIWEISS-SCHÜSSELN	131	HERZFORM	62, 63	KÜHLAKKU FRONT-BOX – 40 x 60	23
FUSS FÜR HANDSCHLAGKESSEL	127	HILFSWERKZEUG FÜR HEBELDOSIERSPENDER	285	KÜHLAKKUS “COLD”	29, 281, 278
<b>G</b>		HOCHZEITSTORTENSTÄNDER	187–189	KÜHLPLATTEN	28, 196
GASBRENNER	324, 325	HÖRNCHENBACKFORM	152	KÜHLTHERMOMETER	159
GASTRO-BLECH – UNIVERSAL	48	<b>I</b>		<b>L</b>	
GASTRO-BRENNER	325	IGELFORMEN	63	LAMM-FORM	65
GASTROHANDSCHUH	163, 323	INDUKTIONSKOCHFELD	302	LEBENSMITTELBEHÄLTER	30
GEBÄCKFÜLLER	273, 284, 285	INFRAROT-THERMOMETER	157	LIKÖR- UND FONDANTTRICHTER	296
GEBÄCKFÜLLER “BLICKLE”	274	<b>K</b>		LOCHBLECH	41–43
GEBÄCKKAPSELN	56	KAISERSEMELDRÜCKER	119	LOCHTÜLLEN-SATZ	209
GEBÄCKSPRITZE	273	KARAMELLISIERER	325	LOCHTÜLLEN	209, 212, 220
GEMÜSEHOBEL	315	KARTOFFELSTAMPFER	313	LÖFFELFLÖTE / LÖFFELBEHÄLTER	225
GEMÜSEMESSER	366	KASSEROLLE	124, 233, 316	<b>M</b>	
GEWÜRZDOSE	322	KASTENFORM	66	MADELEINE	64
GEWÜRZSCHAUFELN	132, 133	KEBAP-MESSER	365	MADELEINE-SILIKONFORM	77
GITTERHAUBE	36	KELLNER- / NOTABLOCKS	197	MAGNETFORMEN	261
GITTERSCHNEIDER	109	KESSELSCHABER	102	MAGNETLEISTE	369
GLASIERTISCH	38	KLIMASCHUTZHAUBE	36	MARZIPAN-MODELLIERSET	153
GLASURPALETTEN	337, 353	KNOBLAUCHPRESSE	329	MARZIPAN-MODELLIERSTÄBE	153
GLASURTRICHTER	135	KOCHMESSER	364	MASCHINENSCHLAGKESSEL	127
GLÄTTER FÜR FONDANT	153	KOCHMÜTZEN	167	MASSENRÜHRSPATEL	107
GN BEHÄLTER AUS POLYCARBONAT	290	KOCHTÖPFE	304	MEHLBESEN	113
GN BEHÄLTER AUS POLYPROPYLEN	288	KONDITORLÖFFEL	107	MEHLSCHAUFELN	132, 133
GN DECKEL	289, 291, 293	KONDITORMESSER	351, 354	MEHLSIEBE	136, 137
GN EINSATZ GN BEHÄLTER AUS EDELSTAHL	45, 292, 293	KONFITÜREN-SCHÜSSELN	130	MESSBECHER-DECKEL	134, 319
GOURMET PASSIERSIEBE	311, 312	KONTAKTGRILL	333	MESSBECHER-SET	134, 319
GRILLROSTE	45, 151, 301	KONVEKTOMATENBLECHE	44, 45	MESSBECHER	134, 135, 319
GRILLZANGEN	193	KREIDESTIFTE	197	MESSER-ABSTREIFBEHÄLTER	370
GROSSKÜCHENSIEBE	311	KUCHEN- & TORTENPLATTEN	175, 180, 181, 182	MESSER-STERILISIERUNGSGERÄT	369
GUGELHUPF-FORM	59	KUCHENBLECHE	61, 66, 68	MESSER	350–368
GUGELHUPF-SILIKONFORM	72, 74, 77, 79, 81			MESSERLEISTE	369

## D STICHWORTREGISTER

Artikel	Seite	Artikel	Seite	Artikel	Seite
MUFFINFORMEN-VERBUND "TULPE"	55			SCHOKOLADEN-FORMEN	234–261
MUFFINFORM "TULPE"	56	<b>R</b>		SCHOKOLADEN-SPENDER	231
<b>N</b>		RAHM- UND CREMEROLLEN	152	SCHOKOLADEN TEMPERIERGERÄTE	231
NIESSCHUTZ	192	RAHMEN FÜR SCHNITTKUCHENBLECH	48, 185	SCHÖPFKELLEN	308
NUDELZANGEN	191	REFRAKTOMETER	159	SCHÜSSELN	124, 126,
<b>O</b>		REGALWAGEN	34, 35, 37	SEIHER	122, 317
OBSTTORTENFORM	61	REHRÜCKENFORM	62	SEITENTEIL FRONT-BOX 40 x 60	23
OLIVENENTSTEINER	329	REIBEN	315	SERVIERLÖFFEL	309
<b>P</b>		REINIGUNGSBÜRSTE	113, 228, 333	SERVIERTABLETTS	174, 225
PALETTE MIT WELLENSCHLIFF	352	RODONFORM	59	SERVIERWAGEN	38
PAPIERMÜTZE "SCHIFFCHEN"	167	ROLLHÖLZER / TEIGROLLEN	112	SERVIERZANGEN	193
PASSIERSIEBE	311	ROSENTÜLLEN	211, 212	SERVIENTENSPENDER / -HALTER	225
PASTETENAUSSTECHE	322	RUNDSIEBE	136, 137	SILIKON-BACKFORMEN	71–81
PENDELSCHÄLER	328	RÜHRBESEN	120, 121, 321,	SILIKONPINSEL	114
PERGAMENTERSATZ	49	RÜHRKEULEN, RÜHRSPATEL	107, 313	SIRUP-SCHÜSSELN	131
PETIT-FOURS-AUSSTECHE	87	RÜHRMASCHINE	297	SNACK-BLECH	177
PFANNENWENDER	309, 358	RÜHRSCHÜSSELN	122, 126, 316, 317, 318	SNACK-VERKAUFSSTÄNDER	178, 179
PINSEL	115	<b>S</b>		SNACKWELLEN	178, 179, 185
PINSEL "SILIKON"	114	SACKSCHAUFELN	133	SPACHTELN	104
PINZETTEN-ZANGEN	194	SAHNE-ABDECKPAPIERE	184	SPAGHETTIÖFFEL	310
PIZZA BALLEBOX	33, 344	SAHNEKAPSELN	332	SPARSCHÄLER	328
PIZZABLECHE	342	SAHNESPENDER	332	SPITZSIEBE	312
PIZZA BLECHZANGE	345	SALATSCHLEUDER	331	SPRINGBLECHE	60
PIZZA BOXEN	26, 27, 348, 349	SALATZANGEN	191	SPRINGFORM	60
PIZZA GITTER / PIZZASCREEN	343	SANDKLANZFORM	59, 69	SPRITZBEUTEL-ABSETZSTÄNDER	203
PIZZA OFENBÜRSTE	345	SANTOKU	365	SPRITZBEUTEL-WANDAUFHÄNGER	203
PIZZA SCHAUFELN	340, 341	SAUCENLÖFFEL	310	SPRITZBEUTEL	201, 202
PIZZA TEIG-DOCKER	345	SAUTEUSEN	305	SPRITZTÜLLEN-SET	217
PIZZA WENDER	358	SAVARIN-SILIKONFORM	71	SPRÜHFLASCHEN	128, 129
PIZZA WIEGEMESSER / PIZZA TEILER	347	SB-DISPLAYS	381	SPRÜHPISTOLE "ALEXO 200"	298
PLANETEN-RÜHRMASCHINE	297	SCHABER	328	SPRÜHPISTOLE "ALEXO 500+"	233
PRALINEN- / TRÜFFELGITTER	150, 151	SCHABER EDELSTAHL	103, 104	SPUCK- UND NIESSCHUTZ	192
PRALINEN-VORRATSDOSE	232	SCHAUMLÖFFEL	308	STABMIXER	294, 295
PRALINENSCHNEIDER "GITARRE"	230	SCHIFFCHEN-SILIKONFORM	87	STAPELBEHÄLTER	33
PRALINENTUNGABELN	232	SCHILLERLOCKENFORMEN	152	STECHMESSER	368
PREISSCHILDER	196	SCHLACHTMESSER	368	STEG FÜR GN BEHÄLTER	293
PROFI-DOSENÖFFNER	330	SCHLAGSCHÜSSELN	126, 318	STERNBANDTÜLLEN	211, 213, 215
PRÄSENTIER-STÄNDER	48, 184	SCHLESINGER	100	STERNTÜLLEN-SATZ	208, 220
PUDERZUCKERSIEBE	136, 137	SCHNEEBESEN	120, 320,	STERNTÜLLEN	208, 210, 220
PUMPEINHEITEN	266	SCHNEIDEBRETTER	371	STIELE	138
<b>Q</b>		SCHNEIDEBRETT + SAFTSCHALE	372	STIELKASSEROLLEN	305
QUERSCHÄLER	328	SCHNEIDEBRETT-SET HACCP	372	STIELSCHABER	105, 106
QUETSCHFLASCHEN	277	SCHNEIDEBRETT HOBEL	373	STIELSCHABER MIT THERMOMETER	105
QUICHE-FORMEN	63, 68	SCHNITTEN- / BACKRAHMEN	145	STIPPROLLER	108
		SCHNITTENRAHMEN	149, 185	STOLLENFORM	67
		SCHNITTKUCHENBLECHE	46, 47	STOLLENRING	143
		SCHNITTKUCHENBRÜCKEN	48, 184	STREICH- UND BUTTERMESSER	359
		SCHOKOLADEN-FONTÄNE	228	STREUER	313, 323

## D STICHWORTREGISTER

Artikel	Seite	Artikel	Seite	Artikel	Seite
STRUDELWALZEN	108	TORTENRINGE	140, 141, 143, 144	WANDHALTERUNG FÜR EINWEGSPRITZBEUTEL	213
STÄNDER FÜR DRUCKKNOPF DOSIERSPENDER	283	TORTENRINGPALETTE	353, 357	WARMHALTEGERÄT	284
STÄNDER FÜR KUCHEN UND PIZZABLECHE	343	TORTENSCHIBEN	142	WARMHALTEPLATTE	17
<b>T</b>					
TEIG- UND PIZZASCHNEIDER	111, 347	TORTENSCHIBENSTÄNDER	142	WASSER-SPRÜHPISTOLE / GEBÄCKSPRÜHER	154
TEIGABSTECHECHER MIT GRIFFLEISTE	101	TORTENSCHUTZ	185	WEIHNACHTSSTERN-FORM	63
TEIGBEHÄLTERWAGEN	39	TORTENSPITZEN + SETS	186	WELLEN-BROMMESSER	352
TEIGDOSIERER	336	TOURNIERMESSER	366	WETZSTAHL	369
TEIGDRÜCKER	119	TRANSPORTHILFE – BÄCKER – 40 x 60	21, 22	WINKELPALETTE	353, 357
TEIGSCHABER / KUCHENLÖSER	60	TRANSPORTHILFE – GN 1/1	17, 18	WOLFSZAHNBLECH	62
TEIGSCHABER	60, 106	TRANSPORTHILFE – TORTE & PIZZA	27, 349	WRAP-HALTER	179
TEIGSCHABER – FLEXIBEL	100	TRANSPORTWAGEN	34, 37–39	WURSTSTÄNDER	192
TEIGSCHABER “SCHLESINGER”	100	TRICHTER	128	WURSTZANGEN	194
TEIGSCHNEIDER	110, 111	TRICHTER “EDHARD”	265, 266	WÄRMEAKKUS	28
TEIGWANNEN	32, 33,123	TRÜFFELFÜLLER	296	<b>Z</b>	
THEKEN-DISPLAY	360	TRÜFFELGITTER	150, 151	ZABAIONESCHÜSSELN	130
THEKEN-DISPLAY VESPERMESSER	360	TÜLLEN-ADAPTER-SET	202	ZIMTSTERN-AUSSTECHECHER	87
THEKENABTRENNUNG	176	TÜLLEN-ADAPTER	217, 218	ZIP-HYGIENE-HANDSCHUH	166
THEKENAUFSTELLER	195	TÜLLEN-SET	220, 221	ZUBEHÖR DOPPELFORMEN	234
THEKENAUFSTELLER FÜR HYGIENISCHEN SCHUTZ	195	TÜLLEN	208–221	ZUBEHÖR SPRÜHPISTOLE “ALEXO 200”	298
THEKENBLECHE / SNACK-BLECH	177	TÜLLENBÜRSTE	217	ZUBEHÖR “EDHARD”	267–272
THEKENPRÄSENTER	194	TÜRSCHLOSS – TRANSPORTWAGEN	37	ZUCKERSIEBE	136, 137
THERMO-GUEST-CHEQUES	197	<b>U</b>			
THERMOMETER	156, 158, 160,161	UNIVERSALMESSER	351, 367	ZUCKERSTREUER	322
TIEFKÜHLMATTEN	54	UNIVERSALSCHERE	369	ZUCKERTÖPFE	130
TISCHAUFSTELLER	196	<b>V</b>			
TOMATENSCHNEIDEGERÄT	331	VERSCHLUSS-CLIPS	203	ZUSCHNEIDMESSER	368
TOP-BOX GN 1/1	15	VERSCHLUSSGRIFF	23	ZUTATENBEHÄLTER / VORRATSBEHÄLTER	317
TOP-BOX GN 1/2	19	VIERKANTREIBE	314		
TOP-BOX ICE 2+3	24	VORLEGEBESTECK	306, 307		
TOP-BOX PIZZA	26, 27, 348, 349	VORRATSBEHÄLTER	30, 125		
TOP-BOX – 40 x 60	20	<b>W</b>			
TORTELETT – SILIKONFORM	71	WAFFELEISEN	334, 335		
TORTEN- UND DEKORIERPLATTE – DREHBAR	181	WAFFELSTÄBE	334		
TORTENBLECHE	142	WAFFEL-SILIKONFOR	78,79		
TORTENBODENSÄGE	147	WAGEN FÜR FAHRGESTELLE & TORTENRINGE	39		
TORTENEINTEILER	148	WANDAUFHÄNGER	124		
TORTENGITTER	150, 151				
TORTENGITTERSTANZE	147				
TORTENHAUBEN	183				
TORTENHEBER	190				
TORTENMESSER	352, 355				
TORTENPLATTEN	180–182				
TORTENPLATTEN – HALBKREIS	180–182				
TORTENRING-SET	142				

# EN ALPHABETICAL INDEX

product	page	product	page	product	page
<b>A</b>					
ACCESSORIES FOR DOUBLE MOULD	240	BOWL STRAINERS	327	COOLING TRAYS	28, 196
ACCESSORIES LEVER DISPENSERS	275, 280–282, 284	BREAD AND DOUGH MARKERS	119	COTTON LINERS	118
ACCESSORIES SPRAY GUN “ALEXO 200”	298	BREAD BRUSHES	112	COUNTER DISPLAY	360
ADAPTER BAR	293	BREAD KNIVES	356	COUNTER DISPLAY “ALLROUND UTILITY KNIFE”	360
ADAPTER FOR FILLER UNITS	267	BREAD MOULDS	66, 116–118	COUNTER DISPLAY “BREAKFAST KNIFE”	360
AIRBRUSH COMPRESSOR	213	BREAD PROOFING BASKETS	116–118	COUNTER SEPARATOR	176
AIRBRUSH GUN	213	BRIOCHE MOULD	63	COUNTER SHOWCASE WITH SNEEZE GUARD	195
ANGULAR KNIVES	355	BRIOCHE–SILICONE	71, 77	CREAM CHARGERS	332
ANGULAR SPATULAS	353	BRUSHES	115	CREAM COVERS	184
APPLE CORER	329	BRUSHES “SILICONE”	114	CREAM INJECTOR “BLICKLE”	274
APPLE PEELING MACHINE	155	BRUSH FOR TUBES	217	CREAM ROLL MOULDS	152
APPLE SLICER	329	BUCKETS	31	CREAM TART MOULDS	326
APRONS	166	BUTCHER KNIVES	368	CREAM WHIPPERS	332
<b>B</b>					
BAGUETTE TRAYS	48	<b>C</b>			
BAKER BLADE	359	CAKE DISPLAYS	46, 47	CREPE MAKER	337
BAKER’S KNIVES	350, 351, 354, 355	CAKE KNIVES	351, 352	CREPE SPATULA	337
BAKING AND FREEZER MATS	54	CAKE MOULDS	61, 66	CREPE SPREADERS	337
BAKING CASES	56	CAKE PLATES	142, 181, 186–188	CREAM INJECTOR	273
BAKING FOIL – PTFE	53	CAKE POLISHER FOR SUGAR PASTE	153	CUTLERY, HEAT-RESISTANT	306, 307
BAKING FRAMES “HEART”	143	CAKE PROTECTION	185	CUTTERS FOR PATE	322
BAKING MITTENS LEATHER	164, 165	CAKE RINGS, ADJUSTABLE	145	CUTTING BOARDS	371
BAKING MITTENS NEOPRENE	163, 323	CAKE SAW	147	CUTTING BOARD SET HACCP	372
BAKING MITTENS SILICONE	163, 323	CAKE SPATULAS	358	CUTTING BOARD WITH DRIPPING TRAY	372
BAKING MITTENS “PREMIUM”	162	CAKE STANDS / CAKE SERVERS	193–195	CUTTING ROLLERS	108
BAKING MITTENS “STANDARD”	163	CANNOLI	152	CUTTING SHEETS	92, 93
BAKING MOULDS – PAPER	57	CASSEROLES	305	<b>D</b>	
BAKING MOULDS – SILICONE	71–81	CATERING SLIDE-IN UNIT GN 1/1	16	DECORATING BAGS	200–202
BAKING RELEASE PAPERS	50, 51, 301	CHALK MARKERS	197	DECORATING CUTTERS	82–99
BAKING RELEASE PAPERS “RONDEN” AND “RINGREIN”	49	CHEESE FLAN PAN	60	DECORATING PLATES	181
BAKING TRAYS	41–44	CHEF 9000	297	DECORATION TUBES	208–221
BALANCER	271	CHEF’S KNIVES	364	DENTS DE LOUP BISCUITS BAKING SHEET	62
BASE FOR MIXING BOWLS	127	CHINESE COLANDER	318	DESSERT AND TART RINGS	140, 141, 326, 327
BASE FOR BOWLS	131	CHOCOLATE / TRUFFLE GRATES	150, 151	DESSERT RINGS	140–144, 146, 327
BISCUIT / PASTRY SYRINGE	273, 284, 285	CHOCOLATE DISPENSER	231	DIGITAL PROBE THERMOMETER	156, 160, 161
BLOWTORCH	324, 325	CHOCOLATE FOUNTAIN	228	DIPPING FORKS	232
BOARD SCRAPER	373	CHOCOLATE GRATERS	239	DISPENSER	53, 284, 285
BONING KNIFE	366, 368	CHOCOLATE MELTERS	231	DISPENSERS FOR GREASE-PROOF PAPERS	184
BOTTLE AND CAN OPENER	330	CHOCOLATE MOULDS	234–261	DISPLAY RISER FOR SLICED CAKES	48
BOTTLES	128, 129	CHOCOLATE SPRAY GUN “ALEXO 500+”	233	DISPLAY TRAYS	169–177
BOTTLE WARMER	276	CHRISTMAS STAR MOULD	63	DISPOSABLE PASTRY BAGS	204–207
BOWLS	124, 126	CHRISTMAS LOAF MOULD	67	DOLLIES	17, 18, 21, 23, 32
BOWL SCRAPERS	102	CINNAMON STAR CUTTER	87	DOLLY FOR BUCKETS	32
		CLEANING BRUSHES	113, 228, 333		
		COOLING PACKS “COLD”	29, 281, 278		
		COOLING PLATES FOR PIZZA	346		

# EN ALPHABETICAL INDEX

product	page	product	page	product	page
DONUTS-SILICONE	75, 79	FRAME FOR CAKE DISPLAY SHEET	48, 185	<b>I</b>	
DOOR LOCK – UTILITY RACK	37	FREE STANDING	133	ICE CREAM CONE HOLDER	226,227
DOSING DISPENSER – TABLE STANDING UNIT	336	FRENCH STAR TUBES	210	ICE CREAM CONTAINERS	224
DOSING METER / FILLING MACHINE “PRALINENFIX B”	229	FRIDGE THERMOMETERS	159	ICE CREAM DIPPERS	223
DOSING METER / FILLING MACHINE “PRALINENFIX D”	229	FRITTER TUBE	211	ICE CREAM SCOOPS	223
DOSING METER “EDHARD”	264–266	FRONT BOX GN 1/1	18	ICE CREAM SPATULAS	222
DOUGH AND PIZZA CUTTERS	111, 347	FRONT BOX – 40 x 60	22	INDUCTION HOB	302
DOUGH CONTAINERS	32, 33, 39, 123	FRUIT FLAN PAN	61	INFRARED THERMOMETERS	157
DOUGH CONTAINER – PIZZA	33, 344	FRUIT STAINER SET	122, 317	INGREDIENT STORAGE CONTAINERS	30
DOUGH CUTTER	110, 111	FRYING PANS, NON-STICK	303	<b>J</b>	
DOUGH DISPENSER	336	FUNNELS	128	JAM BOWLS	130
DOUGHNUT CUTTERS	87	<b>G</b>		<b>K</b>	
DOUGH RULERS	149	GARLIC PRESS	329	KAISERSEMMELE MARKERS	119
DOUGH SCRAPERS	60, 106	GASTRO-TRAY UNIVERSAL	48	KEBAB KNIVES	365
DOUGH SCRAPERS – FLEXIBLE	100	GASTRO MITTENS	163, 323	KETTLES FOR MIXING MACHINES	127
DOUGH SCRAPERS “SCHLESINGER”	100	GLAZE FUNNEL	135	KITCHEN KNIVES	351, 355, 367
DRAINING RACK	373	GLAZING TABLE / UTILITY RACK	38	KITCHEN SCISSORS	369
<b>E</b>		GLOVES – MADE OF COTTON	165	KNIFE-STERILIZER	369
ECLAIRS – SILICONE MOULDS	79	GN CONTAINERS MADE OF POLYPROPYLEN	288	KNIFE-CLEANER	370
EGG CUTTER	328	GN CONTAINERS MADE OF POLYCARBONAT	290	KNIVES	350–360
ELECTRONIC TIMER	161	GN CONTAINERS MADE OF STAINLESS STEEL	292, 293	<b>L</b>	
EXTENSION FRAME	16, 25	GN LID	289, 291, 293	LADLE	308
<b>F</b>		GOURMET BOUILLON-SIEVES	311, 312	LAMB MOULD	65
FASTENING CLIPS	203	GOURMET SIEVES	311	LATTICE CUTTING ROLLERS	109
FILLETING KNIFE	367	GRATERS	315	LATTICE MATRIX	147
FILLER UNITS “EDHARD”	265, 266	GRATES	150, 151	LEVER DISPENSER WITH DONUT ADAPTER	275
FLAN CASE	142	GREASEPROOF PAPER	49	LID FOR DOUGH CONTAINER	33, 123
FLAT WHISK	120, 320	GRIDS	45, 151, 301	LID FOR DOUGH CONTAINER – PIZZA	33, 344
FLORENTINES –SILICONE BAKING MOULDS	74, 77, 78	GRILL TONGS	193	LID FOR STACKABLE CONTAINERS	33
FLOUR AND SUGAR SIEVES	136, 137	GUGELHUPF MOULD	59	LID FOR STEWPOTS	305
FLOUR BRUSHES	113	GUGELHUPF-SILICONE BAKING MOULDS	72, 74, 77, 79, 81	LIDS FOR MEASURING CUPS	134, 319
FLOUR SCOOPS	132, 133	GUITAR CUTTERS	230	LIDS FOR MIXING BOWLS	122, 316
FOOD STORAGE CONTAINERS WITH LID	125, 317	GYROS KNIFE	365	LOAF CAKE MOULD	61, 68
FOOTBALL MOULD	64	<b>E</b>		LOCKING FASTENER	23
FORAGE HAT	167	HACCP MARKING CLIPS	289, 291	LOW FORAGE HAT	167
FOR “EDHARD”	267–272	HANDLES	138	<b>M</b>	
FRAME	149, 185	HEART MOULD	62, 63	MADELEINE MOULD	64
		HEAT PACKS	28	MADELEINE-SILICONE	77
		HEDGEHOG MOULD	63	MAGNET BAR	369
		HORN MOULDS STRAIGHT	152	MAGNET MOULDS	261
		HOT PLATE	17	MARZIPAN MODELLING TOOLS	153
		HYGIENE GLOVES	166	MEASURING CUP-SET	134, 319
				MEASURING CUPS	134, 135, 319
				MEASURING SCOOPS	132

## EN ALPHABETICAL INDEX

product	page	product	page	product	page
MEAT FORK	310	PRETZEL CUTTING DEVICE	360	SETS OF PASTRY CUTTERS	82–99
MENU BOARD	196	PRETZEL STAND	192	SHAKER	313
MIXER	297	PROFESSIONAL CAN OPENERS	330	SHARPENING STEELS	369
MIXING BOWLS	122, 126, 316, 317, 318	PROTECTION – PRETZEL STAND	192	SHOWCASES	195
MIXING PADDLES	319	PROTECTION COVERS	183	SIDE PANEL FRONT BOX 40 x 60	23
MUFFIN PAN	64	PUMP DISPENSERS	278, 279, 282, 283	SILICONE BAKING MOULDS	71–81
MUFFIN TRAYS “TULIP”	55	PUMPS	266	SKIMMER	308
MULTI PURPOSE TONGS	193			SLICER FOR VEGETABLES	314
<b>N</b>		<b>Q</b>		SLICING KNIVES	356
NAPKIN HOLDERS	225	QUICHE MOULDS	63, 68	SNACK SALES RACKS	183–185
<b>O</b>		<b>R</b>		SPAGETTI SPOON	310
OLIVE STONER	329	REFRACTOMETER	159	SPATULAS	110–115, 312, 315
OVEN BROOMS	113	REPLACEMENT CUTTING BOARD	372	SPATULA WITH THERMOMETER	105
OVEN CLOTH	165	REPLACEMENT LID TOP BOX GN 1/2	19	SPEED PEELER	328
OVEN PEELS	138, 139, 346	REPLACEMENT LID TOP BOX ICE	25	SPONGE CAKE –SILICONE BAKING MOULDS	72, 78, 79
<b>P</b>		REPLACEMENT LID – 40 x 60	20	SPOON HOLDERS	225
PALETTE KNIFE WITH SCALLOPED EDGE	352	REPLACEMENT LID – PIZZA	26, 27, 348, 349	SPOONS	107
PALETTE KNIVES / TARTRING SPATULA	353	RIDGED BAKING MOULD	62	SPRAY GUN “ALEXO 200”	298
PAN	303	ROLLER DOCKERS	108	SPRAY GUN “ALEXO 500+”	233
PAN FLIPPERS	358	ROLLING PINS	112	SPREADING AND BUTTERING KNIFE	359
PASTA TONGS	191	ROLL KNIVES	363	SPRINGFORM CAKE TIN	60
PASTRY BAGS	201, 202	ROSE TUBE	211–212	SQUEEZE BOTTLES	277
PASTRY BAGS FOR DOMESTIC USE	202	<b>S</b>		STACKABLE CONTAINERS	33
PASTRY CUTTERS	82–99	SALAD SPINNER	331	STAND FOR DISPENSERS	283
PETIT FOUR CUTTERS	87	SALAD TONGS	191	STAR RIBBON TUBES	211, 213, 215
PIE KNIVES	352, 355	SANTOKU	365	STAR TUBES	208, 210, 220
PIPING TUBE ADAPTER	217, 218	SAUCE DISPENSER	277	STEWPOTS	304
PIPING TUBE ADAPTER SET	202	SAUCE PANS	124, 233, 316	STICK BLENDER	294, 295
PIZZA CHOPPER	347	SAUCE STRAINERS	311, 312	STICKING KNIVES	368
PIZZA DOUGH DOCKERS	345	SAUCE WARMER	303	STOCK POTS	304
PIZZA FLIPPER	358	SAUSAGE STAND	192	STRAINER	122, 317
PIZZA OVEN BRUSH	345	SAUSAGE TONGS	194	SUGAR DISPENSERS	322
PIZZA PEELS	340, 341	SAUTEUSES	305	SUPPORT FOR CAKE- AND PIZZA MOULDS	343
PIZZA SCREENS	343	SAVARIN RING MOULD	59, 69	SUPPORT FOR CAKE PLATES	142
PIZZA SHEET TONG	345	SCRAPERS	103, 104, 106	SUPPORT FOR PASTRY BAGS	203
PIZZA TRAYS	342	SCRAPERS STAINLESS STEEL	103, 104	SWIVEL PEELER	328
PLAIN TUBES	209, 212, 220	SCRAPERS WITH REINFORCED GRIP	101	<b>T</b>	
PLANETARY MIXER	297	SERVICE TROLLEY	38	TEAR-OFF DISPENSERS	52, 339
PLASTIC COVER–DISPOSABLE	36	SERVING SPOON	310	THERMO-GUEST-CHEQUES	197
PLASTIC RIBBONS	185	SERVING TONGS	193	THERMOMETER	156–161
PLUG-IN CARDS	16, 23	SERVING TRAYS	174, 255	TILTING CAKE DECORATING – TURNABLE	180–182
PLUM CAKE – SILICONE	87	SET INCLUDING KNIFE	364	TOMATO SLICER	331
PLUM STONING DEVICE	155	SET OF DECORATING TUBES	217	TOP BOX GN 1/1	15
POTATO MASHER	313	SET OF PLAIN TUBES	209	TOP BOX GN 1/2	19
PRECISION TWEEZER TONGS	194	SET OF STAR TUBES	208, 220	TOP BOX ICE 2+3	24
		SET OF TART RINGS	142		

## EN ALPHABETICAL INDEX

product	page	product	page	product	page
TOP BOX PIZZA	26, 27, 348, 349				
TOP BOX – 40 x 60	20				
TOP FRAME “HOT & COLD”	21, 25				
TRANSPORT ASSISTANCE GN 1/1	17, 18				
TRANSPORT ASSISTANCE – BAKERS – 40 x 60	21, 22				
TRANSPORT ASSISTANCE – CAKE & PIZZA	27, 349				
TRIANGULAR CROISSANT CUTTERS	109				
TRUFFLE FILLER	296				
TRUFFLE GRATES	150, 151				
TUBES	208–221				
TUBES SET	220, 221				
<b>U</b>					
UNIVERSAL KNIVES	351, 367				
UTILIY RACK	34, 35, 37				
<b>V</b>					
VEGETABLE KNIVES	366				
<b>W</b>					
WAFFLE-STICKS	334				
WAFFLE MAKERS	334, 335				
WAFFLE–SILICONE BAKING MOULDS	78, 79				
WAITER PADS	197				
WALL HOLDER FOR DISPOSABLE PASTRY BAGS	213				
WALL RACK	124				
WALL RACKS FOR PASTRY BAGS	203				
WARMING DEVICE	284				
WATER SPRAY GUN	154				
WHISKS	120, 121, 320, 321				
WIRE SKIMMER	308				
WRAP HOLDER	179				
WRENCH FOR LEVER DISPENSERS	285				
<b>Y</b>					
YULE LOG MOULDS	332				
<b>Z</b>					
ZABAGLIONE BOWLS	130				
ZIPPERED PLASTIC COVER	36				

# VORTEILE AUF EINEN BLICK...

ADVANTAGES AT A GLANCE...

VANTAGGI IN SINTESI...

VENTAJAS DE UN VISTAZO...



Für kalte Lebensmittel

For cold food

Per alimenti freddi

Para alimentos fríos

Durch Aussparung am Griff kann Wasser zuverlässig ablaufen

Water can drain reliably through recess on the handle

L'incavo sul manico permette all'acqua di defluire in modo affidabile

El rebaje del mango permite que el agua se escurra con seguridad

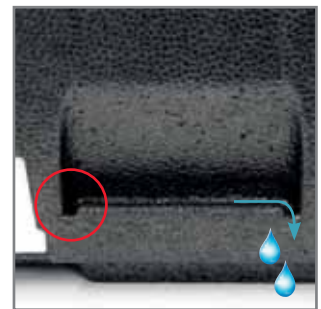

Für warme Lebensmittel

For hot food

Per alimenti caldi

Para alimentos calientes

Perfekt geformte Griffe sorgen für eine optimale Handhabung

Perfectly shaped handles ensure optimal handling

I manici perfettamente sagomati assicurano una maneggevolezza ottimale

Las asas de forma perfecta garantizan un manejo óptimo



Für frische Lebensmittel

For fresh food

Per alimenti freschi

Para alimentos frescos

Robustes Material gewährleistet eine optimale Isolierung

Robust material ensures optimal insulation

Il materiale robusto garantisce un isolamento ottimale

El material robusto garantiza un aislamiento óptimo



Einsteckkarten in 5 Farben für eine individuelle Beschriftung

Plug-in cards in 5 colors for individual labeling

Inserti in 5 colori per l'etichettatura individuale

Tarjetas de 5 colores para el etiquetado individual

Wasserabweisendes Material

Water resistant material

Materiale idrorepellente

Material hidrófugo





Ausgangstemperatur (warm halten)  
Initial temperature (keep warm)

<b>87°C</b>	<b>85,6°C</b>	<b>84,4°C</b>	<b>82,8°C</b>	<b>81,2°C</b>
<b>1 Std./h</b>	<b>2 Std./h</b>	<b>3 Std./h</b>	<b>4 Std./h</b>	

Ausgangstemperatur (kalt halten)  
Initial temperature (keep cold)

<b>0,3°C</b>	<b>0,8°C</b>	<b>0,9°C</b>	<b>1,2°C</b>	<b>1,4°C</b>
<b>1 Std./h</b>	<b>2 Std./h</b>	<b>3 Std./h</b>	<b>4 Std./h</b>	



Eine Griffmulde ermöglicht einfaches Öffnen übers Eck  
A recessed grip allows easy opening across the corner  
Le impugnature incassate consentono un'agevole apertura dall'angolo  
Una empuñadura empotrada facilita la apertura desde la esquina

Hot & Cold  
Praktische Aufsatzrahmen für Wärme- und Kühlakkus  
Practical extension frame for warm and cold packs  
Pratici telai di fissaggio per piastra eutettica e accumulatore di calore  
Prácticos bastidores de fijación para acumulador de frío y acumulador de calor



Aussparung an allen Seiten ermöglicht einfache Entnahme von Behältern aus der Box  
Recess on all sides enables easy removal of containers from the box  
L'incavo su tutti i lati consente di rimuovere facilmente i contenitori dalla box  
El rebaje en todos los lados permite sacar fácilmente los contenedores de la caja

Passgenaue Platzierung der Behälter  
Precise placement of the containers  
Posizionamento preciso dei contenitori  
Colocación precisa de los contenedores

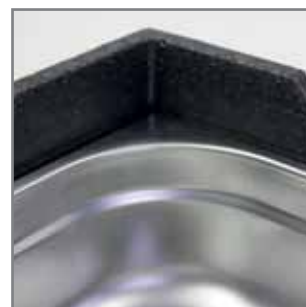

Passgenaues und sicheres Stapeln  
Precise fit and safe stacking  
Impilaggio preciso e sicuro  
Apilado preciso y seguro

Praktischer und robuster Verschluss bei Frontboxen  
Practical and robust closure for front boxes  
Chiusura pratica e robusta per box frontali  
Cierre práctico y robusto para cajas frontales



Praktische Kabelaussparung für die Verwendung von Wärmeplatten  
Practical cable recess for the use of warming plates  
Pratico alloggiamento per i cavi per l'utilizzo di piastre riscaldanti  
Práctico hueco para cables para el uso de placas calentaplatos

Scharniere aus EPP  
Top hygienisch  
Hinges made of EPP  
Top hygienic  
Cerniere in EPP  
Top igienico  
Bisagras de EPP  
Máxima higiene



### Größenangaben und Kombinationsbeispiele

#### Sizes and combination examples

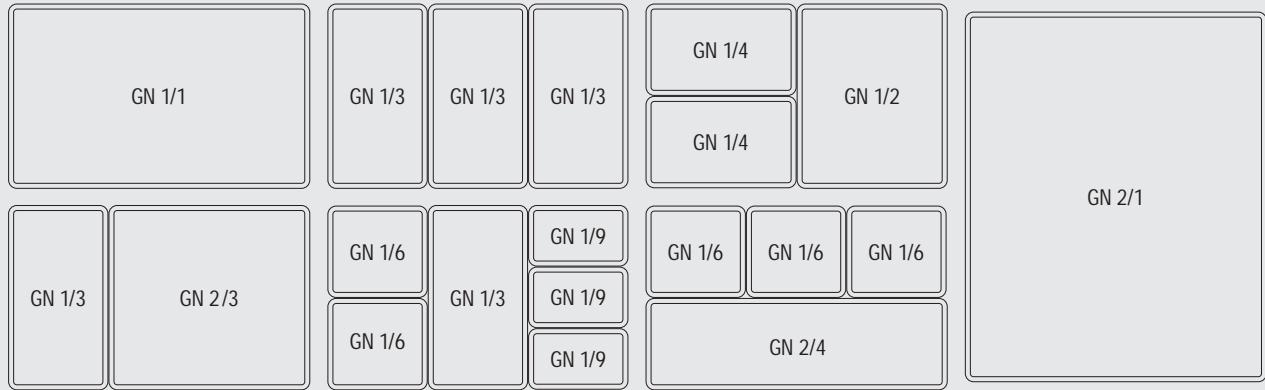

GN 1/1	GN 1/2	GN 1/3	GN 1/4	GN 1/6	GN 1/9	GN 2/1	GN 2/3	GN 2/4
530 x 325 mm	325 x 265 mm	325 x 176 mm	265 x 162 mm	176 x 162 mm	176 x 108 mm	650 x 530 mm	354 x 325 mm	530 x 162 mm

### Angaben zum Volumenvermögen Behälter GN 1/1

#### Data on volume capacity container GN 1/1

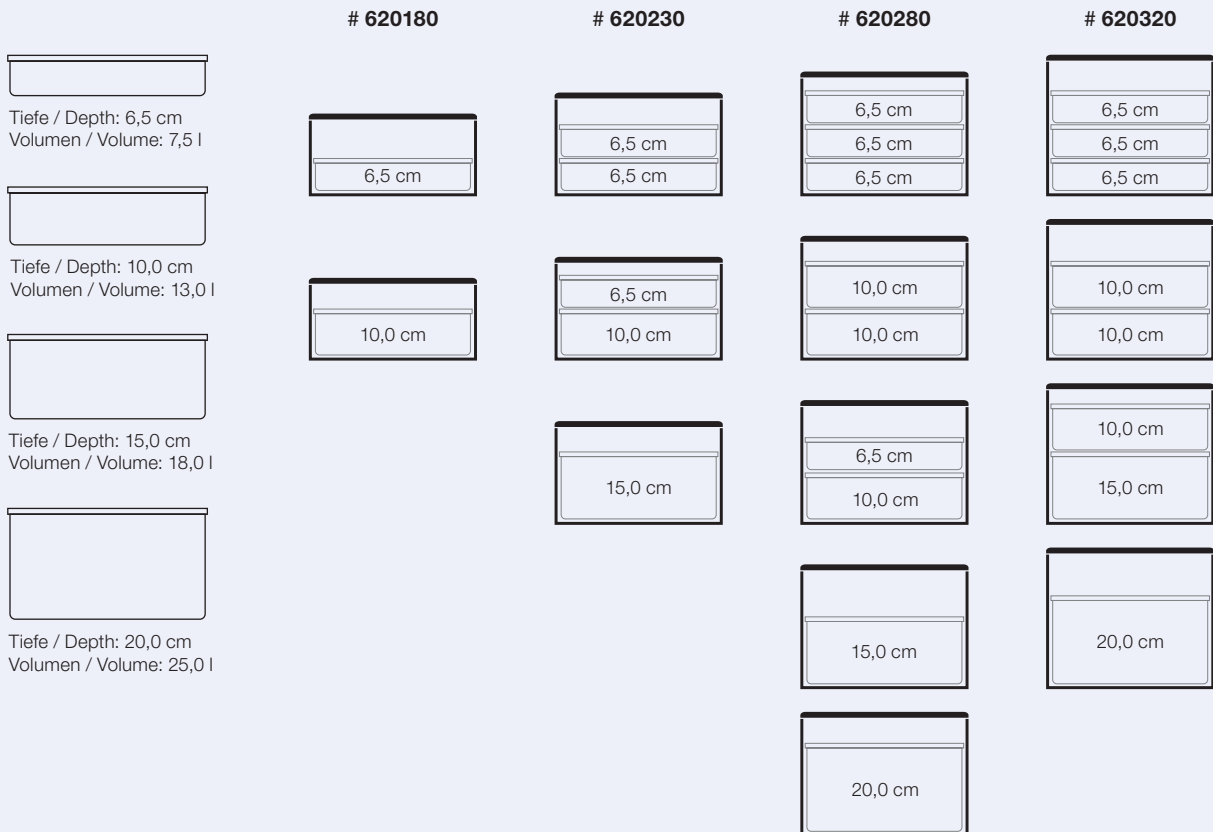

# TOP-BOX GN 1/1

- Inklusive Deckel
  - Inklusive Einsteckkarten-Set
  - Ergonomisches Griffdesign
  - Wasserdichte Innenoberfläche
  - Wasserrinne im Griff
  - Optimale Entnahme von Behältern  
GN 1/1 und GN 1/2 dank Aussparungen  
an allen 4 Seiten
- Including lid
  - Including plug-in card set
  - Ergonomic handle design
  - Waterproof inner surface
  - Water channel in the handle
  - Optimal removal of containers  
GN 1/1 and GN 1/2 thanks to  
recesses on all 4 sides

1



DE	TRANSPORTBOX TOP GN 1/1
EN	TRANSPORT BOX TOP GN 1/1
IT	TRANSPORTINO TOP GN 1/1
ES	CAJA DE TRANSPORTE TOP GN 1/1

#	→□← mm	↔ mm	↑↓ mm
620180	600 x 400 x 180	538 x 338 x 117	21,0
620230	600 x 400 x 230	538 x 338 x 167	30,0
620280	600 x 400 x 280	538 x 338 x 217	39,0
620320	600 x 400 x 320	538 x 338 x 257	46,0



## ZUBEHÖR / ACCESSORIES



DE	ERSATZDECKEL		
EN	SPARE LID	EPP	GN 1/1
IT	COPERCHIO DI RICAMBIO		
ES	TAPA DE RECAMBIO		

- Passend für alle TOP GN 1/1
- Suitable for all TOP GN 1/1

#	→□← mm		
620990	600 x 400 x 35		

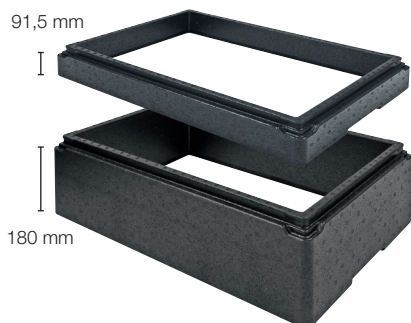

DE	AUFSATZRAHMEN		
EN	EXTENSION FRAME	EPP	GN 1/1
IT	CORNICE SUPERIORE		
ES	MARCO SUPERIOR		

- Passend für alle TOP GN 1/1
- Suitable for all TOP GN 1/1

#	→□← mm		
620900	600 x 400 x 91,5		
620920	600 x 400 x 180		



DE	AUFSATZ		
EN	TOP FRAME	EPP	GN 1/1
IT	CORNICE		
ES	MARCO		

- Passend für alle TOP GN 1/1
- Für Kühl- und Wärmeakkus
- Suitable for all TOP GN 1/1
- For cold and warm packs

#	→□← mm		
620910	600 x 400 x 85		

Kühl- und Wärmeakkus auf Seite 29 / Cold and warm packs on page 29

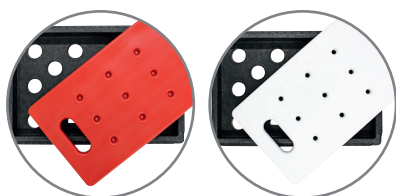

DE	EINSTECKKARTEN-SET		
EN	PLUG-IN CARD SET	PP	GN 1/1
IT	SET DI SCHEDE DA INSERIRE		
ES	JUEGO DE TARJETAS DE INSERCIÓN		

- Passend für alle TOP GN 1/1
- Suitable for all TOP GN 1/1

#			
690000	5-farbig / 5-color		



DE	CATERING-EINSCHUB		
EN	CATERING INSERT	SST	GN 1/1
IT	INSERTO PER CATERING		
ES	INSERTO PARA CATERING		



- Passend für # 620320
- Längseinschub 3 Bleche GN 1/1
- Etagenabstand: ca. 80 mm
- Suitable for # 620320
- Longitudinal insertion 3 trays GN 1/1
- Floor distance: approx. 80 mm

#		↗ mm	→ mm	↑ mm	
690010	3	320	336	269	



## ZUBEHÖR / ACCESSORIES

1

DE	WARMHALTEPLATTE	
EN	WARMING PLATE	  
IT	PIASTRA RISCALDANTE	
ES	PLACA CALIENTAPLATOS	





- |  |  |
|--|--|
| <ul style="list-style-type: none"> <li>• Passend für alle TOP GN 1/1</li> <li>• Schalttemperatur: 75°C</li> <li>• Regelung: vollautomatisch</li> <li>• Automatische Temperaturüberwachung</li> <li>• Vollflächige Temperaturübertragung</li> <li>• Kein Vorheizen notwendig</li> <li>• Unterseitige Carbon-Isolierung</li> <li>• Glatte und spritzwasserfeste Oberfläche</li> <li>• HACCP-konform</li> <li>• Länge Netzkabel: 2 m</li> </ul> | <ul style="list-style-type: none"> <li>• Suitable for all TOP GN 1/1</li> <li>• Switching temperature: 75°C</li> <li>• Control: fully automatic</li> <li>• Automatic temperature monitoring</li> <li>• Full surface temperature transfer</li> <li>• No preheating necessary</li> <li>• Carbon insulation on the underside</li> <li>• Smooth and splash-proof surface</li> <li>• HACCP compliant</li> <li>• Length of power cable: 2 m</li> </ul> |
|--|--|



#	→□← mm		
690100	480 x 280 x 10	100 W	230 V / 50-60 Hz

DE	TRANSPORTTROLLEY	
EN	DOLLY	
IT	CARRELLO DI TRASPORTO	
ES	CARRO DE TRANSPORTE	

- |   |  |
|---|--|
| <ul style="list-style-type: none"> <li>• Geeignet für alle TOP GN 1/1 (Außenmaß 60x40)</li> <li>• Geeignet für Behälter (Außenmaß 60x40)</li> </ul> | <ul style="list-style-type: none"> <li>• Suitable for all TOP GN 1/1 (external dimensions 60x40)</li> <li>• Suitable for containers (external dimensions 60x40)</li> </ul> |
|---|--|

#		<b>kg</b>
202085	 0/4 Lenkrollen feststellbar / 0/4 swivel castors lockable	ca. 250
202092	 1/4 Lenkrollen feststellbar / 1/4 swivel castors lockable	ca. 180
202096	 0/4 Lenkrollen feststellbar / 0/4 swivel castors lockable	ca. 250
202099	 0/4 Lenkrollen feststellbar / 0/4 swivel castors lockable	ca. 250



# FRONT-BOX GN 1/1



# 640699

Scharnier einfach und schnell wechselbar /  
Hinge can be changed easily and quickly

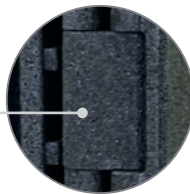

## Angaben zum Volumenvermögen Behälter GN 1/1

Data on volume capacity container GN 1/1

Tiefe / Depth: 6,5 cm  
Volumen / Volume: 7,5 l

Tiefe / Depth: 10,0 cm  
Volumen / Volume: 13,0 l

Tiefe / Depth: 15,0 cm  
Volumen / Volume: 18,0 l

Tiefe / Depth: 20,0 cm  
Volumen / Volume: 25,0 l

6,5 cm
6,5 cm
6,5 cm
6,5 cm
6,5 cm
6,5 cm

10,0 cm
10,0 cm
10,0 cm
10,0 cm

15,0 cm
15,0 cm
15,0 cm

20,0 cm
20,0 cm

Türe ist bis zu 270°  
schwenkbar /  
Door can be swivelled  
up to 270°



DE	TRANSPORTBOX FRONT GN 1/1
EN	TRANSPORT BOX FRONT GN 1/1
IT	TRANSPORTINO FRONT GN 1/1
ES	CAJA DE TRANSPORTE FRONT GN 1/1

- Geeignet für Behälter, Bleche in GN 1/1
- Inklusive Einsteckkarten-Set
- Ergonomisches Griffdesign
- Kabelaussparung für Wärmeplattenverwendung
- Suitable for containers, trays in GN 1/1
- Including plug-in card set
- Ergonomic handle design
- Cable recess for warming plate use

#	→□← mm	↔ mm	↑↓
620660	628 x 445 x 625	533 x 331 x 525	91,0



DE	TRANSPORTTROLLEY	
EN	DOLLY	
IT	CARRELLO DI TRASPORTO	GN 1/1
ES	CARRO DE TRANSPORTE	

#	ALU	2/4 Lenkrollen feststellbar / 2/4 swivel castors lockable	/kg	für/for #
202094	ALU	2/4 Lenkrollen feststellbar / 2/4 swivel castors lockable	ca. 180	620660

**i** Zubehör auf Seite 23 / Accessories on page 23

**Angaben zum  
Volumenvermögen  
Behälter GN 1/2**

**Data on  
volume capacity  
container GN 1/2**

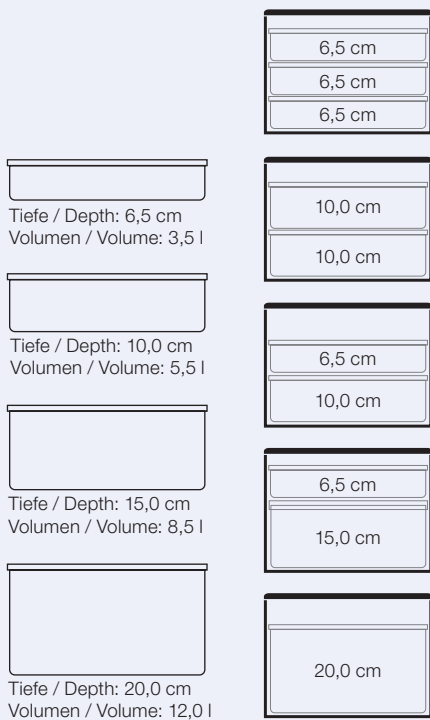

# TOP-BOX GN 1/2



DE	TRANSPORTBOX TOP GN 1/2
EN	TRANSPORT BOX TOP GN 1/2
IT	TRANSPORTINO TOP GN 1/2
ES	CAJA DE TRANSPORTE TOP GN 1/2

- Inklusive Deckel
- Ergonomisches Griffdesign
- Including lid
- Ergonomic handle design

#	→□← mm	↔ mm	↑ mm
630280	390 x 330 x 280	330 x 270 x 217	19,0



DE	ERSATZDECKEL	EPP	GN 1/2
EN	SPARE LID		
IT	COPERCHIO DI RICAMBIO		
ES	TAPA DE RECAMBIO		

- Passend für TOP GN 1/2
- Suitable for TOP GN 1/2

#	→□← mm
630990	390 x 330 x 35



# TOP-BOX 60x40

- Geeignet für E2-Kisten, Stapelbehälter, Bleche in 60x40
- Inklusive Deckel
- Ergonomisches Griffdesign
- Suitable for E2 boxes, stacking containers, trays in 60x40
- Including lid
- Ergonomic handle design



# 640180 32,0 l
# 640220 42,0 l
# 640260 53,0 l
# 640360 80,0 l



DE	TRANSPORTBOX TOP 60x40
EN	TRANSPORT BOX TOP 60x40
IT	TRANSPORTINO TOP 60x40
ES	CAJA DE TRANSPORTE TOP 60x40

#	→□← mm	↔ mm	l
640180	685 x 485 x 180	625 x 425 x 120	32,0
640220	685 x 485 x 225	625 x 425 x 160	42,0
640260	685 x 485 x 265	625 x 425 x 200	53,0
640360	685 x 485 x 365	625 x 425 x 300	80,0



DE	ERSATZDECKEL	
EN	SPARE LID	
IT	COPERCHIO DI RICAMBIO	EPP 60x40
ES	TAPA DE RECAMBIO	

- Passend für alle TOP 60x40
- Suitable for all TOP 60x40

#	→□← mm
640990	685 x 485 x 35



**i** Kühl- und Wärmeakkus auf Seite 29 /  
Cold and warm packs on page 29

DE	AUFSATZ		
EN	TOP FRAME	EPP	60x40
IT	CORNICE		
ES	MARCO		

- Passend für alle TOP 60x40
- Für Kühl- und Wärmeakkus
- Suitable for all TOP 60x40
- For cold and warm packs

#	→  ← mm
640900	685 x 485 x 85

### ZUBEHÖR / ACCESSORIES



DE	CATERING-EINSCHUB		
EN	CATERING INSERT	SST	60x40
IT	INSERTO PER CATERING		
ES	INSERTO PARA CATERING		

- Passend für # 640360
- Längseinschub 3 Auflagen 60x40
- Etagenabstand: ca. 85 mm
- Suitable for # 640360
- Longitudinal insertion 3 layers 60x40
- Floor distance: approx. 85 mm

#		 mm	→ mm	↑ mm
690020	3	450	415	297

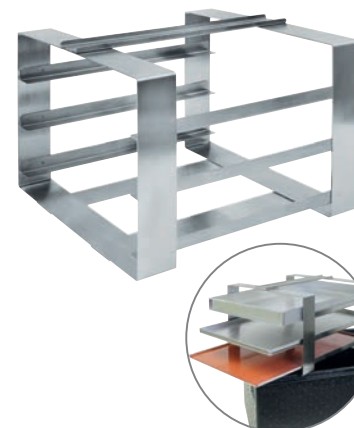

DE	TRANSPORTTROLLEY		
EN	DOLLY		60x40
IT	CARRELLO DI TRASPORTO		
ES	CARRO DE TRANSPORTE		

- Geeignet für alle TOP 60x40 (Außenmaß 68,5 x 48,5)
- Suitable for all TOP 60x40 (external dimensions 68.5 x 48.5)

#		 kg
202086	ALU 0/4 Lenkrollen feststellbar / 0/4 swivel castors lockable	ca. 250



# FRONT-BOX 60x40



# 640699

Scharnier einfach und schnell wechselbar /  
Hinge can be changed easily and quickly

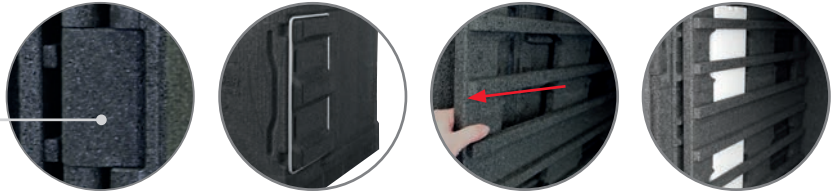

Türe ist bis zu 270°  
schwenkbar /  
Door can be swivelled  
up to 270°



DE	TRANSPORTBOX FRONT 60x40
EN	TRANSPORT BOX FRONT 60x40
IT	TRANSPORTINO FRONT 60x40
ES	CAJA DE TRANSPORTE FRONT 60x40

- Geeignet für max. 7 Bleche 60x40 / Schnittkuchenbleche
- Geeignet für Stapelbehälter 60x40 / E2-Kisten
- Inklusive Einsteckkarten-Set
- Ergonomisches Griffdesign
- Kabelaussparung für Wärmeplattenverwendung
- Optionaler Seiteneinschub mit einer Kapazität von bis zu 8 Kühl-Akkus
- Nutzhöhe: 60 mm
- Suitable for max. 7 trays 60x40 / cut cake trays
- Suitable for stacking containers 60x40 / E2 boxes
- Including plug-in card set
- Ergonomic handle design
- Cable recess for warming plate use
- Optional side insert with a capacity of up to 8 cold packs
- Usable height: 60 mm

#	→□← mm	↔ mm	↑↓
640640	710 x 587 x 685	615 x 405 x 585	146,0



DE	TRANSPORTTROLLEY	
EN	DOLLY	
IT	CARRELLO DI TRASPORTO	60x40
ES	CARRO DE TRANSPORTE	

#	ALU	kg	für/for #
202097	2/4 Lenkrollen feststellbar / 2/4 swivel castors lockable	ca. 250	640640

## ZUBEHÖR / ACCESSORIES

1

DE	KÜHLAKKU		
EN	COLD PACK		60x40
IT	PIASTRA EUTETTICA		
ES	ACUMULADOR DE FRIO		

- Passend für FRONT 60x40
- Suitable for FRONT 60x40

#	↗ mm	→ mm	↑ mm
281040	200	140	20



DE	SEITENEINSCHUB		
EN	SIDE INSERT	EPP	60x40
IT	INSERTO LATERALE		
ES	INSERTO LATERAL		

- Passend für FRONT 60x40
- Geeignet für linke oder rechte Seite
- Lieferumfang ohne Kühlakkus
- Suitable for FRONT 60x40
- Suitable for left or right side
- Delivery without cold packs

#	↗ mm	→ mm	↑ mm
640691	607	557	37



DE	SCHARNIER			
EN	HINGE	EPP	60x40	GN 1/1
IT	CERNIERA			
ES	BISAGRA			

- Passend für FRONT 60x40
- Passend für FRONT GN 1/1
- Suitable for FRONT 60x40
- Suitable for FRONT GN 1/1

#	↗ mm	→ mm	↑ mm
640699	80	35	142

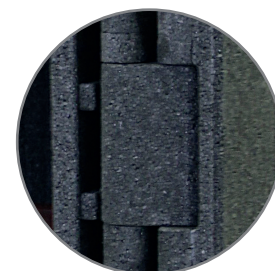

DE	VERSCHLUSSGRIFF			
EN	LOCKING HANDLE	SST	60x40	GN 1/1
IT	MANIGLIA DI CHIUSURA			
ES	ASA DE CIERRE			

- Passend für FRONT 60x40
- Passend für FRONT GN 1/1
- Suitable for FRONT 60x40
- Suitable for FRONT GN 1/1

#	↗ mm	→ mm	↑ mm
640692	450	250	10



DE	EINSTECKKARTEN-SET			
EN	PLUG-IN CARD SET	PP	60x40	GN 1/1
IT	SET DI SCHEDE DA INSERIRE			
ES	JUEGO DE TARJETAS DE INSERCIÓN			

- Passend für FRONT 60x40
- Passend für FRONT GN 1/1
- Suitable for FRONT 60x40
- Suitable for FRONT GN 1/1

#	
690000	5-farbig / 5-color ○ ● ● ● ●

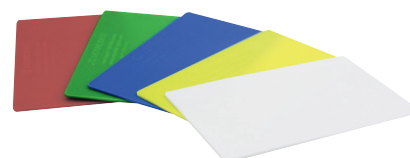

# TOP-BOX ICE



DE	TRANSPORTBOX TOP ICE 2
EN	TRANSPORT BOX TOP ICE 2
IT	TRANSPORTINO TOP ICE 2
ES	CAJA DE TRANSPORTE TOP ICE 2



- Geeignet für 2 Eisbehälter # 199614  
360 x 250 x 120 mm, 8,7 L
- Geeignet für 1 Kühlakku GN 1/4 mittig
- Inklusive Deckel
- Ergonomisches Griffdesign
- Lieferumfang ohne Eisbehälter und Kühlakku
- Suitable for 2 ice containers # 199614  
360 x 250 x 120 mm, 8.7 l
- Suitable for 1 cold pack GN 1/4 centered
- Including lid
- Ergonomic handle design
- Delivery without ice containers and cold pack

#	→□← mm	↔ mm	↑↓
660215	600 x 400 x 215	2 x (360 x 250 x 120)	17,4



DE	TRANSPORTBOX TOP ICE 3
EN	TRANSPORT BOX TOP ICE 3
IT	TRANSPORTINO TOP ICE 3
ES	CAJA DE TRANSPORTE TOP ICE 3



- Geeignet für 3 Eisbehälter # 199612  
360 x 165 x 180 mm, 7,3 L
- Geeignet für 2 Kühlakkus GN 1/4 mittig
- Inklusive Deckel
- Ergonomisches Griffdesign
- Lieferumfang ohne Eisbehälter und Kühlakkus
- Suitable for 3 ice containers # 199612  
360 x 165 x 180 mm, 7.3 l
- Suitable for 2 cold packs GN 1/4 centered
- Including lid
- Ergonomic handle design
- Delivery without ice containers and cold packs

#	→□← mm	↔ mm	↑↓
660270	600 x 400 x 270	3 x (360 x 165 x 180)	21,9

## ZUBEHÖR / ACCESSORIES

1

DE	ERSATZDECKEL		
EN	SPARE LID	EPP	ICE
IT	COPERCHIO DI RICAMBIO		
ES	TAPA DE RECAMBIO		

- Passend für alle TOP ICE
- Suitable for all TOP ICE

#	→□← mm	
660990	600 x 400 x 70	



DE	AUFSATZRAHMEN		
EN	EXTENSION FRAME	EPP	ICE
IT	CORNICE SUPERIORE		
ES	MARCO SUPERIOR		

- Passend für alle TOP ICE
- Suitable for all TOP ICE

#	→□← mm	
620900	600 x 400 x 91,5	
620920	600 x 400 x 180	



DE	AUFSATZ		
EN	TOP FRAME	EPP	ICE
IT	CORNICE		
ES	MARCO		

- Passend für alle TOP ICE
- Suitable for all TOP ICE
- Für Kühl- und Wärmeakkus
- For cold and warm packs

#	→□← mm	
620910	600 x 400 x 85	

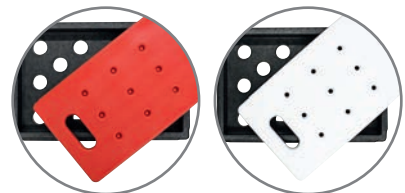

 Kühl- und Wärmeakkus auf Seite 29 / Cold and warm packs on page 29

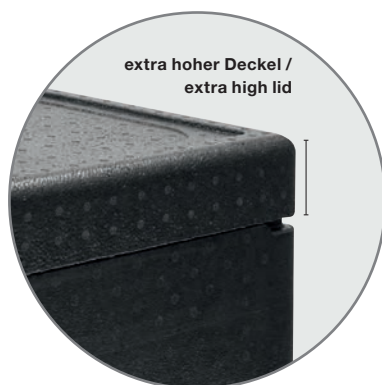

# TOP-BOX PIZZA

- Speziell für heiße Pizzen
- Auch geeignet für frische Lebensmittel, Getränke, Kuchen
- Inklusive Deckel
- Ergonomisches Griffdesign
- Especially for hot pizzas
- Also suitable for fresh food, drinks, cakes
- Including lid
- Ergonomic handle design



\* mit Noppen für bessere Luftzirkulation /  
\* with knobs for improved air circulation



DE	TRANSPORTBOX TOP PIZZA
EN	TRANSPORT BOX TOP PIZZA
IT	TRANSPORTINO TOP PIZZA
ES	CAJA DE TRANSPORTE TOP PIZZA

#	→□← mm	↔ mm	↑↓
650165	410 x 410 x 165	350 x 350 x 100	12,0
650240	410 x 410 x 240	350 x 350 x 175	21,0
650330 *	410 x 410 x 330	350 x 350 x 265	32,0
650395	410 x 410 x 395	350 x 350 x 330	40,0

DE	ERSATZDECKEL	
EN	SPARE LID	EPP PIZZA S
IT	COPERCHIO DI RICAMBIO	
ES	TAPA DE RECAMBIO	

- Passend für alle TOP PIZZA S
- Suitable for all TOP PIZZA S

#	→□← mm
650990	410 x 410 x 35



DE	TRANSPORTBOX TOP PIZZA
EN	TRANSPORT BOX TOP PIZZA
IT	TRANSPORTINO TOP PIZZA
ES	CAJA DE TRANSPORTE TOP PIZZA

#	→□← mm	↔ mm	↑ mm
651165	480 x 480 x 182	420 x 420 x 117	21,0
651260 *	480 x 480 x 265	420 x 420 x 200	35,0



1

DE	ERSATZDECKEL	EPP	PIZZA	L
EN	SPARE LID			
IT	COPERCHIO DI RICAMBIO			
ES	TAPA DE RECAMBIO			

- Passend für alle TOP PIZZA L
- Suitable for all TOP PIZZA L

#	→□← mm
651990	480 x 480 x 35



DE	TRANSPORTBOX TOP PIZZA
EN	TRANSPORT BOX TOP PIZZA
IT	TRANSPORTINO TOP PIZZA
ES	CAJA DE TRANSPORTE TOP PIZZA

#	→□← mm	↔ mm	↑ mm
652280	595 x 595 x 182	535 x 535 x 115	33,0



DE	ERSATZDECKEL	EPP	PIZZA	XL
EN	SPARE LID			
IT	COPERCHIO DI RICAMBIO			
ES	TAPA DE RECAMBIO			

- Passend für TOP PIZZA XL
- Suitable for TOP PIZZA XL

#	→□← mm
652990	595 x 595 x 35



DE	TRANSPORTHILFE	ALU	PIZZA	S
EN	TRANSPORT ASSISTANCE			
IT	AIUTO AL TRASPORTO			
ES	AIUTO AL TRASPORTO			

- Passend für # 650240, 650330, 650395
- Geeignet für Pizza & Torte
- Mit Bodenlochung: 3 mm
- Suitable for # 650240, 650330, 650395
- Suitable for pizza & cake
- With perforated base: 3 mm

#	↗ mm	→ mm	↑ mm
690030	340	340	150





DE	KÜHLPLATTEN
EN	COOLING TRAYS
IT	VASSOIO RAFFREDDANTE
ES	BANDEJA REFRIGERADA



Material: Edelstahl

- Integrierte Kühlelemente fest verschlossen
- Bei – 20 °C ca. 4 Stunden gefrieren

Material: stainless steel

- Integrated cooling elements firmly closed
- Freeze at – 20 °C for approx. 4 hours



#		↗ mm	→ mm	↑ mm
281020	GN 1/1	530	325	45
281021	GN 1/2	325	265	45



DE	WÄRMEAKKUS
EN	HEAT PACKS
IT	ACCUMULATORI DI CALDO
ES	PLACAS DE CALOR



- Bei max. 85 °C für ca. 30 Minuten im Ofen oder Wasserbad erhitzen

- Heat at max. 85 °C for approx. 30 minutes in the oven or water bath



#	GN / cm	↔ mm	⚖ g
281030	1/1	530 x 325 x 30	4060
281031	1/2	325 x 265 x 30	2360
281032	1/4	265 x 162 x 30	1080
281033	40 x 60	600 x 400 x 28	5110

DE	KÜHLAKKUS „COLD“
EN	COOLING PACKS „COLD“
IT	PIASTRE EUTETTICHE „COLD“
ES	PLACAS EUTÉCTICAS „COLD“



- Platten horizontal und mindestens 24 Stunden vor dem Gebrauch in den Gefrierschrank legen
- Place plates horizontally in the freezer for at least 24 hours before use



1

#	GN / cm	↔ mm	g
281001	1/9	176 x 108 x 30	500
281002	1/4	265 x 162 x 30	1000
281003	1/3	325 x 176 x 30	1500
281016	1/2	265 x 325 x 32	2100
281004	1/1	530 x 325 x 30	3950
281005	40 x 60	600 x 400 x 28	5200
281017	20 x 14	200 x 140 x 20	450
281006	1/9	176 x 108 x 30	500
281007	1/4	265 x 162 x 30	1000
281008	1/3	325 x 176 x 30	1500
281018	1/2	265 x 325 x 32	2100
281009	1/1	530 x 325 x 30	3950
281010	40 x 60	600 x 400 x 28	5200
281040	20 x 14	200 x 140 x 20	450
281011	1/9	176 x 108 x 30	500
281012	1/4	265 x 162 x 30	1000
281013	1/3	325 x 176 x 30	1500
281041	1/2	265 x 325 x 32	2100
281014	1/1	530 x 325 x 30	3950
281015	40 x 60	600 x 400 x 28	5200
281042	20 x 14	200 x 140 x 20	450

-3°C



-12°C



-21°C



GN 1/1



GN 1/2



GN 1/3



GN 1/4



GN 1/9



Gefriertemperatur der eutektischen Platte muss immer unter 6 °C der Schmelztemperatur der eutektischen Flüssigkeit liegen:

The freezing temperature of the eutectic plate must always be 6 °C below the melting temperature of the eutectic liquid:

	Einzufrieren bei / Freeze at	
-3°C	- 9° C	
-12°C	- 18° C	
-21°C	- 27° C	

- Verlängert die Temperaturbeständigkeit
- unterstützt die Lieferkette nach HACCP-Standard
- Nahezu unendlich wiederverwendbar
- Formstabil
- Nicht spülmaschinengeeignet

- Extends the temperature resistance
- Supports the supply chain according to HACCP standard
- Almost infinitely reusable
- Dimensionally stable
- Not dishwasher safe



©Thomas Söllner - stock.adobe.com







DE	LEBENSMITTELBEHÄLTER / VORRATSBEHÄLTER – FAHRBAR	
EN	INGREDIENT STORAGE TROLLEY	PP 
IT	CONTENITORE MOBILE DA STOCCAGGIO	
ES	CONTENEDOR DE INGREDIENTES CON RUEDAS	

- |  |  |
|--|--|
| <ul style="list-style-type: none"> <li>• 4 Rollen</li> <li>• Abgerundete Ecken</li> <li>• Glatte Oberfläche für maximale Hygiene</li> <li>• Deckel durchsichtig</li> <li>• 2-teilig, inklusive Schaufel</li> </ul> | <ul style="list-style-type: none"> <li>• 4 wheels</li> <li>• Rounded corners</li> <li>• Smooth surface to allow spotless cleaning</li> <li>• Transparent lid</li> <li>• 2-pieces, including scoop</li> </ul> |
|--|--|

#	↔ mm	l 
200890	333 x 743 x 711	81,0
200894	425 x 710 x 705	100,0

**NEW**



DE	EIMER	    
EN	BUCKET	
IT	SECCHIO	
ES	CUBO	

- Mit Henkel
- Mit Ausguss
- Integrierte Skala
- With handle
- With spout
- Integrated scale

#	Ø ↑ mm	Ø ↓ mm	↑ mm	l
200880	305	220	275	12,0
200881	320	230	285	15,0
200882	350	250	315	18,0



#200881

1



DE	EIMER	    
EN	BUCKET	
IT	SECCHIO	
ES	CUBO	

- Mit Henkel
- Mit Ausguss
- Integrierte Skala
- With handle
- With spout
- Integrated scale

#	Ø ↑ mm	Ø ↓ mm	↑ mm	l
200830	280	193	300	10,0
200840	316	235	335	15,0



#200830





DE	EIMER	    
EN	BUCKET	
IT	SECCHIO	
ES	CUBO	

- Mit Henkel
- Integrierte Skala
- With handle
- Integrated scale

#	Ø ↑ mm	Ø ↓ mm	↑ mm	l
200850	300	200	250	10,0
200860	310	200	270	12,0
200870	325	200	310	15,0



#200860

DE	DECKEL	   
EN	LID	
IT	COPERCHIO	
ES	TAPA	

- Mit Griff
- With handle

#	Ø mm	↑ mm	für/for #
200855	300	20	200850
200865	310	20	200860
200875	325	20	200870



#200865



#202010

DE	KÜBEL				
EN	BUCKET		HDPE	-20 +100 °C	
IT	SECCHIO				
ES	CUBO				

- Mit 2 Seitengriffen
- With 2 side handles

#	↑ Ø mm	↓ Ø mm	↑ mm	↓ mm
202000	390	310	410	35,0
202010	455	365	480	50,0
202020	495	390	570	75,0
202030	520	415	675	100,0



#202025

DE	DECKEL			
EN	LID		PP	-20 +120 °C
IT	COPERCHIO			
ES	TAPA			

- Mit Griff
- With handle

#	Ø mm	↑ mm	für/for #
202005	400	30	202000
202015	470	40	202010
202025	500	40	202020
202035	540	40	202030

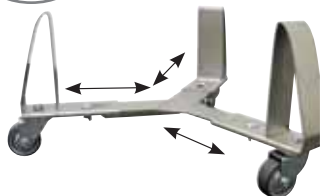

DE	TRANSPORTTROLLEY		
EN	TRANSPORT DOLLY		SST
IT	CARELLO DI TRASPORTO		
ES	CARRO DE TRANSPORTE		

- Geeignet für alle Kübel
- Ausführung: verstellbar
- Suitable for all buckets
- Type: adjustable

#		kg	Ø mm	↑ mm
202098	0/3 Lenkrollen feststellbar / 0/3 swivel castors lockable	ca. 150	350-460	215



DE	TEIGWANNE			
EN	DOUGH CONTAINER		LDPE	-15 +60 °C
IT	CONTENITORE PER IMPASTO			
ES	CUBETA PARA MASA			

- Mit 2 Seitengriffen
- With 2 side handles

#	→ □ ← mm	↔ mm	↓ mm
200970	Ø 450 x 175	Ø 270 x 172	14,0



DE	TEIGWANNE			
EN	DOUGH CONTAINER		HDPE	-40 +90 °C
IT	CONTENITORE PER IMPASTO			
ES	CUBETA PARA MASA			

#	→ □ ← mm	↔ mm	↓ mm
200971	Ø 480 x 160	Ø 380 x 155	19,0

DE	TEIGWANNE		
EN	DOUGH CONTAINER	HDPE	-10 +40 °C
IT	CONTENITORE PER IMPASTO		
ES	CUBETA PARA MASA		

#	→□← mm	↔ mm	↑ mm
200960	530 x 410 x 140	440 x 320 x 130	20,0
200962	440 x 320 x 155	395 x 275 x 150	12,0
200963	610 x 440 x 150	550 x 375 x 145	25,0



#200962

DE	TEIGWANNE		
EN	DOUGH CONTAINER	PP	-20 +90 °C
IT	CONTENITORE PER IMPASTO		
ES	CUBETA PARA MASA		

- Mit 2 Seitengriffen
- With 2 side handles

#	→□← mm	↔ mm	↑ mm
202180	600 x 400 x 82	500 x 300 x 77	13,0

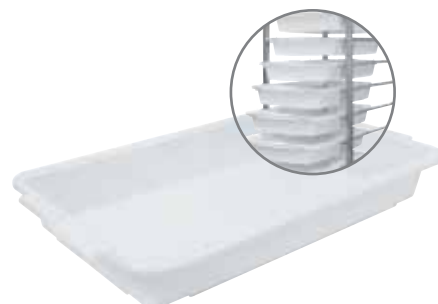

DE	DECKEL		
EN	LID	PP	-20 +90 °C
IT	COPERCHIO		
ES	TAPA		

- Passend für # 202180
- Suitable for # 202180

#	↗ mm	→ mm	↑ mm	für/for #
202181	600	400	35	202180



**i** Deckel ist beidseitig verwendbar / Lid can be used on both sides

DE	STAPELBEHÄLTER		
EN	STACKING CONTAINER	HDPE	-20 +100 °C
IT	CONTENITORE IMPILABILE		
ES	CONTENEDOR APILABLE		

- Mit 2 Seitengriffen
- With 2 side handles

#	→□← mm	↔ mm	↑ mm
202200	570 x 415 x 290	455 x 355 x 285	50,0
202210	640 x 440 x 330	530 x 380 x 325	65,0
202220	740 x 460 x 360	610 x 400 x 355	90,0



#202210

DE	DECKEL		
EN	LID	PP	-20 +110 °C
IT	COPERCHIO		
ES	TAPA		

- Mit 2 Seitengriffen
- With 2 side handles



#	↗ mm	→ mm	↑ mm	für/for #
202205	575	430	20	202200
202215	645	445	20	202210
202225	750	470	20	202220



#202215

**i** Deckel sind nicht beidseitig verwendbar / Lids can't be used on both sides



DE	TRANSPORTWAGEN / REGALWAGEN		
EN	UTILITY RACK	SST	
IT	CARRELLO PORTAVASSOI		
ES	CARRO PORTA BANDEJAS		

- Rahmen aus Vierkantprofilen 25 x 25 mm; Höhe: 1,8 Meter
  - **Blecheinschub längs**
  - Blechauflage: 30 mm; Materialstärke: 1 mm
  - **Selbstmontage**, inkl. 6 Schrauben und Schlüssel
  - Lenkrollen aus Thermoplast Ø: 100 mm
  - 2 Rollen feststellbar
  - Abstand: 79 mm
- Frame made of square profiles 25 x 25 mm; height: 1.8 m
  - **Tray insertion lengthwise**
  - Sheet support: 30 mm, thickness 1 mm
  - **Self-assembly**, incl. 6 screws and key
  - Thermoplastic wheels Ø: 100 mm
  - 2 lockable wheels
  - Distance: 79 mm

#	↗ mm	→ mm	↑ mm	
385010	600	400	1800	20
385030	530	325	1800	20

GN 1/1

- Abstand: 88 mm
- Distance: 88 mm



GN 1/1

385040	600	400	1800	18
385050	530	325	1800	18

- Abstand: 106 mm
- Distance: 106 mm



385000	600	400	1800	15
--------	-----	-----	------	----

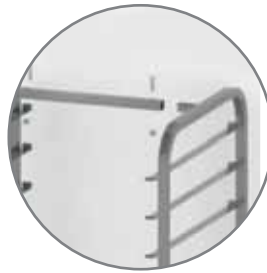

DE	UNIVERSAL TRANSPORTWAGEN		
EN	UTILITY RACK	SST	
IT	CARRELLO PORTAVASSOI		
ES	CARRO PORTA BANDEJAS		

- Verschweißte Ausführung
- **Für Bleche 80 x 60 cm, 78 x 58 cm und 60 x 40 cm**
- Mit Winkelaufkantung hinten
- Materialstärke: 1 mm
- Rahmen aus Vierkantprofilen 25 x 25 mm
- Fahrbar auf Lenkrollen
- 2 Rollen feststellbar
- Welded type
- **For trays 80 x 60 cm, 78 x 58 cm and 60 x 40 cm**
- With angle upstand rear
- Material thickness: 1 mm
- Frame made of square profiles 25 x 25 mm
- Mobile on swivel castors
- 2 lockable wheels

#	↗ mm	→ mm	↑ mm	
385180	800	660	1800	20

 Transportwagen: Nicht für Temperaturen unter 0 °C geeignet!  
Utility rack: Not suitable for temperatures below 0 °C!

DE	TRANSPORTWAGEN / REGALWAGEN	SST 
EN	UTILITY RACK	
IT	CARRELLO PORTAVASSOI	
ES	CARRO PORTA BANDEJAS	

- |   |   |
|---|---|
| <ul style="list-style-type: none"> <li>• Rahmen aus Vierkantprofilen 25 x 25 mm</li> <li>• Verschweißte Ausführung</li> <li>• Blechauflage: 30 mm; Materialstärke: 1 mm</li> <li>• Abstand: 87 mm</li> <li>• Lenkrollen aus Thermoplast Ø: 100 mm</li> <li>• 2 Rollen feststellbar</li> </ul> | <ul style="list-style-type: none"> <li>• Frame made of square profiles 25 x 25 mm</li> <li>• Welded type</li> <li>• Sheet support: 30 mm, thickness 1 mm</li> <li>• Distance: 87 mm</li> <li>• Thermoplastic wheels Ø: 100 mm</li> <li>• 2 lockable wheels</li> </ul> |
|---|---|

**Blecheinschub längs**

**Tray insertion lengthwise**

#	↗ mm	→ mm	↑ mm	
385100	600	400	1800	18
385120	530	325	1800	18

GN 1/1



**Blecheinschub quer**

**Tray insertion crosswise**

#	↗ mm	→ mm	↑ mm	
385015	600	400	1800	18
385035	530	325	1800	18

GN 1/1



DE	TRANSPORTWAGEN / REGALWAGEN – Z-FORM	SST 
EN	UTILITY RACK – Z-SHAPE	
IT	CARRELLO PORTAVASSOI - FORMA A Z	
ES	CARRO PORTA BANDEJAS - FORMA Z	

- |  |  |
|--|--|
| <ul style="list-style-type: none"> <li>• Rahmen aus Vierkantprofilen 25 x 25 mm</li> <li>• Verschweißte Ausführung</li> <li>• <b>Blecheinschub längs</b></li> <li>• Blechauflage: 30 mm, Materialstärke 1 mm</li> <li>• Abstand: 87 mm</li> <li>• Z-Form ermöglicht das Zusammenschieben mehrerer Wagen, optimal für eine platzsparende Aufbewahrung</li> <li>• Lenkrollen aus Thermoplast Ø 80 mm</li> <li>• 2 Rollen feststellbar</li> </ul> | <ul style="list-style-type: none"> <li>• Frame made of square profiles 25 x 25 mm</li> <li>• Welded type</li> <li>• <b>Tray insertion lengthwise</b></li> <li>• Sheet support: 30 mm, thickness 1 mm</li> <li>• Distance: 87 mm</li> <li>• Z-shape allows several trolleys to be pushed together, optimal for space-saving storage</li> <li>• Thermoplastic wheels Ø 80 mm</li> <li>• 2 lockable wheels</li> </ul> |
|--|--|

#	↗ mm	→ mm	↑ mm	
385200	600	400	1770	18
385205	530	325	1770	18

GN 1/1

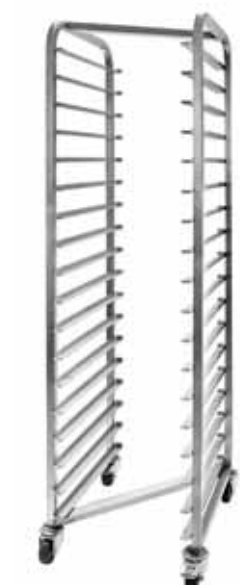



DE	KLIMASCHUTZHAUBE / GITTERHAUBE	
EN	ZIPPERED PLASTIC COVER	LDPE
IT	COPRICARRELLO IN PLASTICA CON CERNIERA	
ES	CUBRE CARRO DE PLASTICO	

- Mit Reißverschluss, • With zipper
- Für Transport- und Stikkenwagen • Weight: ca. 300 g/m<sup>2</sup>
- Gewicht: ca. 300 g/m<sup>2</sup>

#	für/for mm		↔ mm
391950	580 x 780	längs / lengthwise	1650 x 720 x 860
391951	570 x 980	längs / lengthwise	1650 x 720 x 1070
391952	600 x 400	quer / crosswise	1650 x 690 x 450
391953	600 x 400	längs / lengthwise	1650 x 490 x 640
391954	GN 1/1 – 530 x 325	längs / lengthwise	1650 x 425 x 570



→ mm

DE	KLIMASCHUTZHAUBE – EINWEG	
EN	PLASTIC COVER – DISPOSABLE	PE
IT	COPRICARRELLO IN PLASTICA - USA E GETTA	
ES	CUBRE CARRO DE PLASTICO – DESECHABLE	

- Materialstärke: 14 µ • Thickness: 14 µ
- Für Transportwagen • For utility rack

#	für/for mm	Zuschnitt / blank cut	↗ mm	→ mm	↑ mm
391960*	GN 2/1 – 650 x 530	100	770	750	1900
391961	GN 1/1 – 600 x 400	100	650	500	1850

#	für/for mm	Rolle / roll	↗ mm	→ mm	↑ mm
391970*	GN 1/1 – 530 x 325	100	770	630	1800
391971*	GN 2/1 – 650 x 530	100	770	750	1900
391972	600 x 400	100	650	500	1850

\* für zwei Transportwagen nebeneinander / for two utility racks to each other

DE	ABROLLGERÄT	
EN	DISPENSER	PVC
IT	DISTRIBUTORE	
ES	DISPENSADOR	

#	↔ mm
391980	890 x 140 x 100



DE	TRANSPORTWAGEN / REGALWAGEN	
EN	UTILITY RACK	SST 
IT	CARRELLO PORTAVASSOI	
ES	CARRO PORTA BANDEJAS	

- Blecheinschub längs
- Geschlossene, verschweißte Ausführung
- Lenkrollen aus Thermoplast Ø: 100 mm
- Blechauflage: 30 mm; Materialstärke: 1 mm
- Tray insertion lengthwise
- Closed, welded type
- Thermoplastic wheels Ø: 100 mm
- Sheet support: 30 mm, thickness 1 mm

#		für/for mm	↔ mm
385029	15	600 x 400	470 x 650 x 1420
385009	15	530 x 325	395 x 580 x 1420

GN 1/1



1

DE	TÜRSCHLOSS
EN	DOOR LOCK
IT	CHIUSURA DELLA PORTA
ES	CERRADURA DE PUERTA

- Zum Nachrüsten
- Inklusive 2 Schlüssel
- For retrofitting
- 2 keys included

#	1 Set – für/for #
385099	385029 + 385009



① Stikken- und Ofenwagen für alle gängigen Öfen (MIWE, W&P, REVENT, etc.) sowie Frosterwagen auf Anfrage.

Mobile oven racks for all common ovens (MIWE, W&P, REVENT, etc.) as well as mobile freezer racks on request.

① Transportwagen: Nicht für Temperaturen unter 0 °C geeignet!  
Utility rack: Not suitable for temperatures below 0 °C!

DE	GLASIERTISCH / REGALWAGEN	<div style="border: 1px solid black; padding: 2px; display: inline-block;">SST</div>
EN	GLAZING TABLE / UTILITY RACK	
IT	CARRELLO PORTAVASSOI/PIANO PER GLASSATURA	
ES	CARRO PORTA BANDEJAS / MESA PARA GLASEAR BOLLERÍA	

- |  |   |
|--|---|
| <ul style="list-style-type: none"> <li>• Verschweißte Ausführung</li> <li>• Abstand der Etagen: ca. 7 cm</li> <li>• Für Bleche 40 x 60 cm</li> <li>• Lenkrollen aus Thermoplast Ø 100 mm</li> <li>• 2 Rollen feststellbar</li> </ul> | <ul style="list-style-type: none"> <li>• Welded type</li> <li>• Distance between the supports: approx. 7 cm</li> <li>• For trays 40 x 60 cm</li> <li>• Thermoplastic wheels castors Ø 100 mm</li> <li>• 2 lockable wheel</li> </ul> |
|--|---|

#	↗ mm	→ mm	↑ mm	≡	
385500	665	400	900	10	
385510	605	465	900	10	

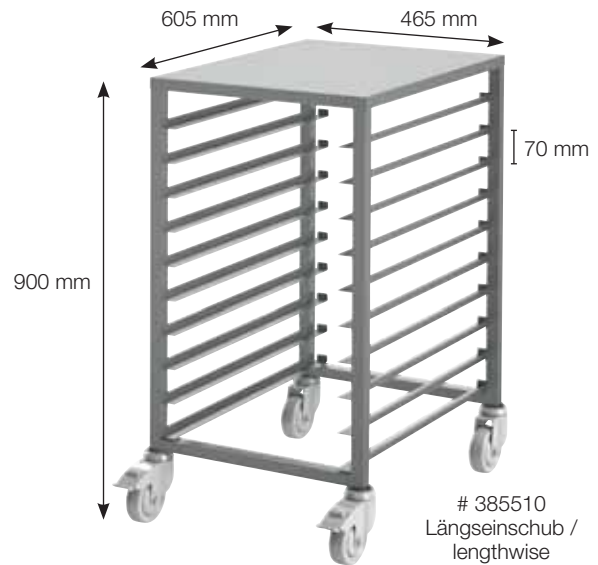
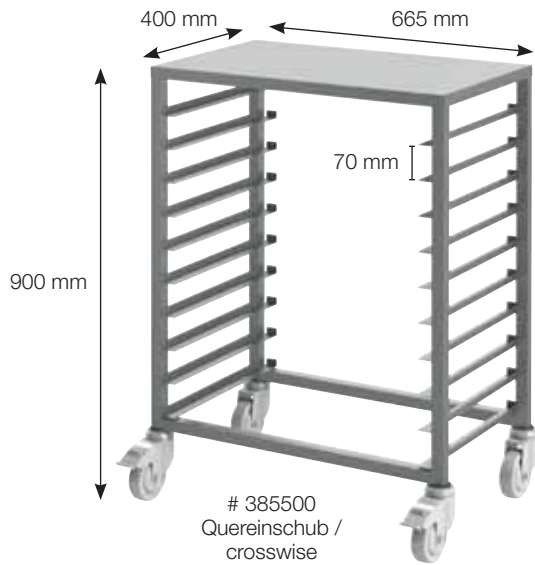

DE	SERVIERWAGEN	<div style="border: 1px solid black; padding: 2px; display: inline-block;">SST</div>
EN	SERVICE TROLLEY	
IT	CARRELLO DI SERVIZIO	
ES	CARRO DE SERVICIO	

- |   |  |
|---|--|
| <ul style="list-style-type: none"> <li>• Verschweißte Ausführung</li> <li>• Lenkrollen aus Thermoplast Ø 100 mm</li> <li>• 2 Rollen feststellbar</li> </ul> | <ul style="list-style-type: none"> <li>• Welded type</li> <li>• Thermoplastic wheels castors Ø 100 mm</li> <li>• 2 lockable wheel</li> </ul> |
|---|--|

#	↗ mm	→ mm	↑ mm	≡	
385550	845	504	945	2	
385551	845	504	945	3	





DE	BEHÄLTERWAGEN /TEIGBEHÄLTERWAGEN	
EN	CONTAINER TROLLEY	SST 
IT	CARRELLI PORTACONTENITORI	
ES	CARRO PARA CONTENEDORES	

- Für 8 Behälter á 25,0 L (# 200963)
- Verschweißte Ausführung
- Deckel fest verschweiß
- **Ohne Behälter**
- For 8 25.0 l containers (# 200963)
- Welded type
- Cover fixed welded
- **Without containers**

#	↗ mm	→ mm	↑ mm
202095	670	470	1760



1

DE	TEIGWANNE	
EN	DOUGH CONTAINER	HDPE    
IT	CONTENITORE PER IMPASTO	
ES	CUBETA PARA MASA	

#	→□← mm	↔ mm	↑ mm
200963	610 x 440 x 150	550 x 375 x 145	25,0



DE	WAGEN FÜR FAHRGESTELLE & TORTENRINGE	
EN	RACK FOR DOLLYS & TART RINGS	SST 
IT	PORTA CARRELLI & ANELLI PER TORTE	
ES	BASTIDOR PARA CARRETILLAS & AROS PARA TARTAS	

- Verschweißte Ausführung
- Mit je 2 Lenk- und 2 Bockrollen
- Welded type
- 2 fixed and 2 steering castors

#	↗ mm	→ mm	↑ mm
202089	750	470	1503

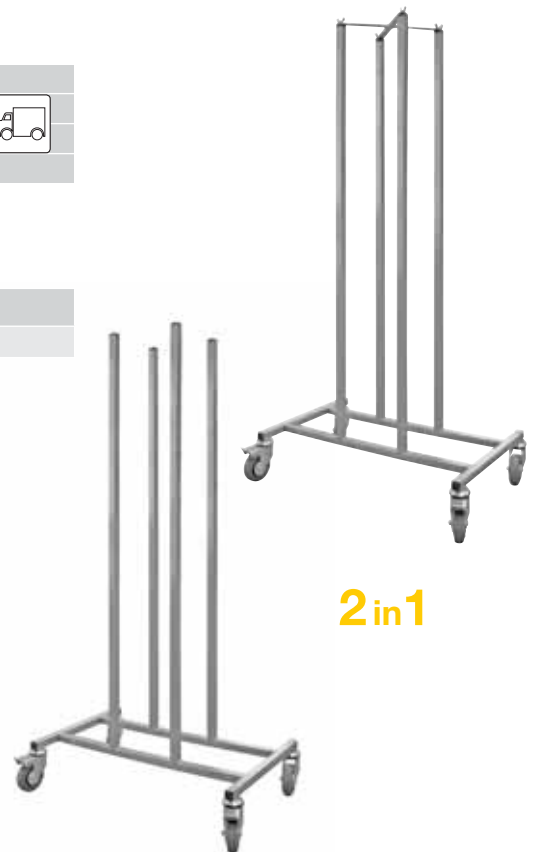
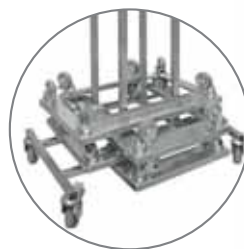
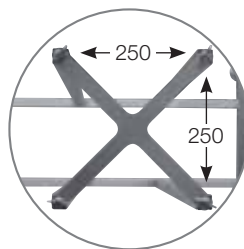
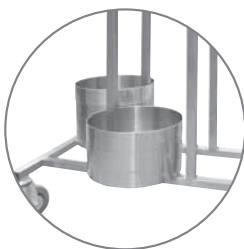

2in1

# BACKBLECHE / BAKING TRAYS



## Aluminium

- Robust
- Stapelbar
- Einfach zu reinigen
- Hohe Stabilität
- Langlebig

- Robust
- Stackable
- Easy to clean
- High stability
- Durable



## Silikon-Beschichtung

- Antihftbeschichtung auf Silikonbasis
- Farbe: rot
- Hohe Lebensdauer
- Einsetzbar bis maximal + 260 °C

- Silicone-based non-stick coating
- Color: red
- High durability
- Can be used up to a maximum of + 260 °C



## TYNECK-Beschichtung

- Thermoplastische Beschichtung
- Farbe: schwarz
- Sehr lange Lebensdauer
- Laugenresistent
- Hohe Antihft-Eigenschaft
- Sehr robuste Oberfläche
- Schnitt- und kratzfest (bei handelsüblichem Gebrauch und Umgang)
- Einsetzbar bis maximal + 260 °C

- Thermoplastic coating
- Color: black
- Very high durability
- Resistant to alkalis / lye
- High non-stick property
- Very robust surface
- Cut and scratch resistant (for normal commercial use and handling)
- Can be used up to a maximum of + 260 °C



## TYNECK RED-Beschichtung

- Mehrschicht-Antihftsystembeschichtung
- Farbe: rot
- Sehr lange Lebensdauer
- Lauge- und säurebeständig
- Zuckerbeständig
- Sehr hohe Antihft-Eigenschaft
- Sehr robuste Oberfläche
- Schnitt- und kratzfest (bei handelsüblichem Gebrauch und Umgang)
- Einsetzbar bis maximal + 260 °C

- Multi-layer system non stick coating
- Color: red
- Very high durability
- Resistant to alkalis / lye and acid
- Resistant to sugar
- High non-stick property
- Very robust surface
- Cut and scratch resistant (for normal commercial use and handling)
- Can be used up to a maximum of + 260 °C

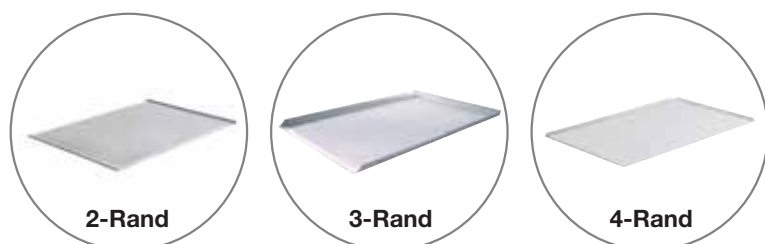

DE	BACKBLECHE / LOCHBLECHE – ALUMINIUM
EN	BAKING TRAYS – MADE OF ALUMINIUM
IT	TEGLIE IN ALLUMINIO
ES	BANDEJAS PARA HORNO DE ALUMINIO



mit und ohne Lochung /  
with or without perforation

	↔ mm		#	⊙ mm	⊥ mm		↑ mm	
	530 x 325	<b>GN 1/1</b> 4 Seiten 45° / 4 sides 45°	381050	–	1,5	unbeschichtet/ uncoated	10	
	530 x 325	<b>GN 1/1</b> 4 Seiten 45° / 4 sides 45°	381051	3	1,5	unbeschichtet/ uncoated	10	
	530 x 325	<b>GN 1/1</b> 4 Seiten gezogen / 4 sides deep-drawn	381057	3	1,5	unbeschichtet/ uncoated	10	
	354 x 325	<b>GN 2/3</b> 4 Seiten 45° / 4 sides 45°	381060	3	1,5	unbeschichtet/ uncoated	10	
	325 x 530	<b>GN 1/1</b> 4 Seiten, Ränder 90°, verschweißt 4 sides 90°, welded	381063	–	2,0	unbeschichtet/ uncoated	15	
	530 x 325	<b>GN 1/1</b> 4 Seiten 45° / 4 sides 45°	381052	3	1,5	Silikon / silicone	10	
	650 x 530	<b>GN 2/1</b> 4 Seiten 45° / 4 sides 45°	381054	3	1,5	Silikon / silicone	10	
	354 x 325	<b>GN 2/3</b> 4 Seiten 45° / 4 sides 45°	381058	3	1,5	Silikon / silicone	10	
	530 x 325	<b>GN 1/1</b> 4 Seiten 45° / 4 sides 45°	382000	–	1,5	TYNECK	10	
	530 x 325	<b>GN 1/1</b> 4 Seiten gezogen / 4 sides deep-drawn	382030	–	1,5	TYNECK	10	
	354 x 325	<b>GN 2/3</b> 4 Seiten 45° / 4 sides 45°	382020	–	1,5	TYNECK	10	
	354 x 325	<b>GN 2/3</b> 4 Seiten 45° / 4 sides 45°	382040	3	1,5	TYNECK	10	
	530 x 325	<b>GN 1/1</b> 4 Seiten 45° / 4 sides 45°	382010	3	1,5	TYNECK	10	

Material: Edelstahl

Made of stainless steel

	530 x 325	<b>GN 1/1</b> 4 Seiten 45° / 4 sides 45°	383052	3	0,8	TYNECK RED	10	<b>NEW</b>
--	-----------	--	--------	---	-----	------------	----	------------

mit und ohne Lochung /  
with or without perforation

DE	BACKBLECHE / LOCHBLECHE
EN	BAKING TRAYS
IT	TEGLIE
ES	BANDEJAS PARA HORNO



Material: Aluminium (AlMn)

Made of aluminium

	↔ mm		#	⊙ mm	⊥ mm		↑ mm	
	600 x 400	4 Seiten 45° / 4 sides 45°	381100	3	1,5	unbeschichtet / uncoated	10	
	600 x 400	4 Seiten 45° / 4 sides 45°	381106	-	1,5	unbeschichtet / uncoated	10	
	600 x 400	3 Seiten 90° / 3 sides 90° 1 kurze Seite offen 45° / 1 short side open	381101	3	1,5	unbeschichtet / uncoated	20	
	600 x 400	4 Seiten, Ränder 90°, verschweißt 4 sides 90°	381110	-	1,5	unbeschichtet / uncoated	20	
	600 x 400	4 Seiten, Ränder 90°, verschweißt 4 sides 90°, welded	381061	3	1,5	unbeschichtet / uncoated	20	
	600 x 400	4 Seiten gezogen / 4 sides deep-drawn	381108	3	1,5	unbeschichtet / uncoated	10	
	600 x 400	3 Seiten 90° / 3 sides 90° 1 kurze Seite offen 45° / 1 short side open	381109	-	1,5	unbeschichtet / uncoated	10	
	600 x 400	4 Seiten 45° / 4 sides 45°	381102	3	1,5	Silikon / silicone	10	
	600 x 400	4 Seiten 45° / 4 sides 45°	382100	-	1,5	TYNECK	10	
	600 x 400	4 Seiten 45° / 4 sides 45°	382110	3	1,5	TYNECK	10	

Material: Edelstahl

Made of stainless steel

	600 x 400	4 Seiten 45° / 4 sides 45°	383110	3	0,8	TYNECK RED	10	
--	-----------	-------------------------------	--------	---	-----	------------	----	--

DE	BACKBLECHE / LOCHBLECHE
EN	BAKING TRAYS
IT	TEGLIE
ES	BANDEJAS PARA HORNO



mit und ohne Lochung /  
with or without perforation

Material: Aluminium (AlMn)

Made of aluminium

	↔ mm		#	⊙ mm	⊥ mm		↑ mm	
	400 x 300	4 Seiten 45° / 4 sides 45°	381020	–	1,5	unbeschichtet/ uncoated	10	
	400 x 300	4 Seiten 45° / 4 sides 45°	381021	3	1,5	unbeschichtet/ uncoated	10	
	400 x 300	4 Seiten 45° / 4 sides 45°	381022	3	1,5	Silikon / silicone	10	
	780 x 580	2 Seiten 70° / 2 sides 70° lange Seiten offen / long sides open	381005	3	2,0	unbeschichtet/ uncoated	10	
	780 x 580	3 Seiten 90° / 3 sides 90° 1 kurze Seite offen / 1 short side open	381006	3	1,5	unbeschichtet/ uncoated	25	
	780 x 580	3 Seiten 90° / 3 sides 90° 1 kurze Seite offen / 1 short side open	381007	3	2,0	unbeschichtet/ uncoated	25	
	780 x 580	2 Seiten 70° / 2 sides 70° lange Seiten offen / long sides open	381200	–	2,0	unbeschichtet/ uncoated	10	
	780 x 580	3 Seiten 90° / 3 sides 90° 1 kurze Seite offen / 1 short side open	381201	–	1,5	unbeschichtet/ uncoated	25	
	780 x 580	2 kurze Seiten 45° / 2 short sides 45° lange Seiten offen / long sides open	381127	3	2,0	unbeschichtet/ uncoated	10	
	980 x 580	3 Seiten 90° / 3 sides 90° 1 kurze Seite offen / 1 short side open	381000	3	1,5	unbeschichtet/ uncoated	25	

Material: Edelstahl

Made of stainless steel

	780 x 580	4 Seiten 45° / 4 sides 45°	383200	3	0,8	TYNECK RED	10	
--	-----------	-------------------------------	--------	---	-----	------------	----	--



DE	BACKBLECHE / KONVEKTOMATENBLECHE	
EN	BAKING TRAYS	
IT	TEGLIE	
ES	BANDEJAS PARA HORNO	

Material: Stahlblech, Granit-Emaile

Made of steel, enamel granite

- Beidseitig beschichtet
- Materialstärke: 1,0 mm

- Coated on both sides
- Thickness: 1.0 mm

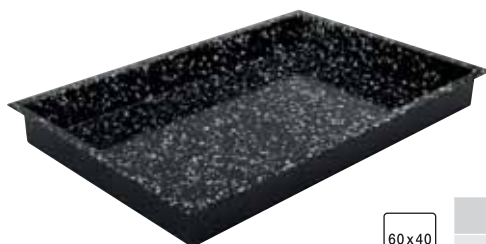

600 x 400 – Ausführung: 4 Seiten 90°

600 x 400 – Type: 4 sides 90°

#	↗ mm	→ mm	↑ mm
382562	600	400	60

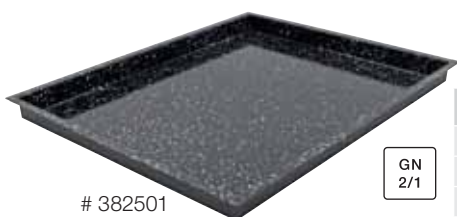

# 382501

GN 2/1 – Ausführung: 4 Seiten 90°

GN 2/1 – Type: 4 sides 90°

#	↗ mm	→ mm	↑ mm
382500	530	650	20
382501	530	650	40
382502	530	650	60

GN 1/1 – Ausführung: 4 Seiten 90°

GN 1/1 – Type: 4 sides 90°

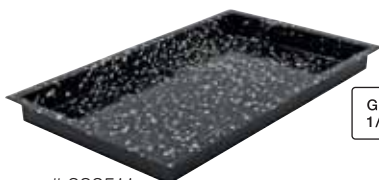

# 382511

#	↗ mm	→ mm	↑ mm
382510	530	325	20
382511	530	325	40
382512	530	325	60

GN 2/3 – Ausführung: 4 Seiten 90°

GN 2/3 – Type: 4 sides 90°

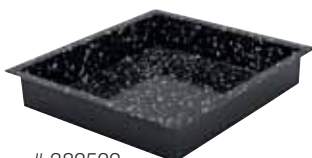

# 382522

#	↗ mm	→ mm	↑ mm
382520	354	325	20
382521	354	325	40
382522	354	325	60

DE	GN-BACKBLECHE / KONVEKTOMATENBLECHE
EN	GN-BAKING TRAYS
IT	TEGLIE GN
ES	BANDEJAS PARA HORNO GN



Material: Stahlblech, Emaille, schwarz  
 • Beidseitig beschichtet

Made of steel, enamel, black  
 • Coated on both sides

#	↗ mm	→ mm	↑ mm	⏊ mm	l
382530	530	325	20	0,8	2,5
382531	530	325	40	0,8	5,3
382532	530	325	65	0,8	8,8
382533	325	265	40	0,8	2,5
382534	325	265	65	0,8	4,0
382535	325	176	40	0,8	1,8
382536	325	176	65	0,8	2,4



GN 1/1  
GN 1/2  
GN 1/3

2

DE	GN-BEHÄLTER AUS EDELSTAHL
EN	GN-CONTAINERS MADE OF STAINLESS STEEL
IT	CONTENITORI GN IN ACCIAIO INOX
ES	CONTENEDORES GASTRONORM ACERO INOXIDABLE

SST

#	GN	↑ mm	l
530200	1/1	20	1,9
530201	1/1	40	5,4
530202	1/1	65	8,7
530203	1/1	100	13,0



GN 1/1

DE	GRILLROSTE
EN	GRIDS
IT	GRIGLIE
ES	REJILLAS

SST

#		↗ mm	→ mm	≡	Ø mm	Drähte Ø mm / wire Ø mm
156110		600	400	2	6	24 / 3
156111	GN 1/1	530	325	1	7	20 / 3
156112	GN 2/3	354	325	1	5	15 / 2
156113	GN 2/1	650	530	3	6	32 / 2

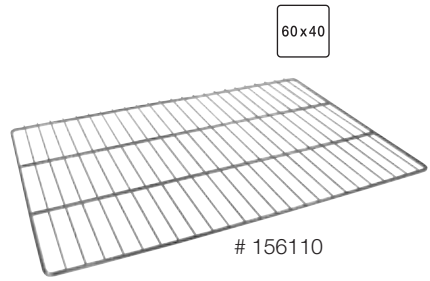

60x40



# 156111

GN 1/1

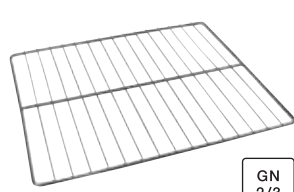

# 156112

GN 2/3

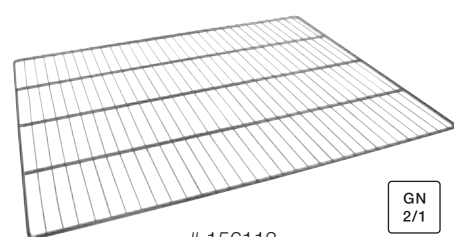

# 156113

GN 2/1



DE	SCHNITTKUCHENBLECHE MIT VORSATZSCHIENE
EN	CAKE DISPLAY SHEET WITH JOINT BAR
IT	TEGLIE PER TORTE CON BORDO REMOVIBILE
ES	BANDEJAS CON LATERAL DESMONTABLE

**Material: Aluminium**

- Materialstärke: 1,5 mm

**Made of aluminium**

- Thickness: 1.5 mm

#	↗ mm	→ mm	↑ mm	
995810	580	100	50	
995820	580	200	50	
995840	580	400	50	
995830	300	200	50	



**Ersatzschienen  
Aluminium**

**Replacement joint bars  
Aluminium**

#	→ mm	für / for #	
995811	100	995810	
995821	200	995820	
995841	400	995840	

**Material: Edelstahl**

- Materialstärke: 1 mm

**Made of stainless steel**

- Thickness: 1 mm

#	↗ mm	→ mm	↑ mm	
997810	580	100	50	
997820	580	200	50	
997840	580	400	50	

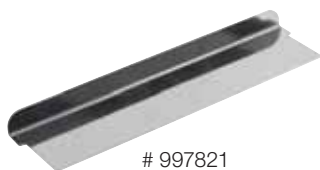

**Ersatzschienen  
Edelstahl**

**Replacement joint bars  
Stainless steel**

#	→ mm	für / for #	
997811	100	997810	
997821	200	997820	
997841	400	997840	

DE	SCHNITTKUCHENBLECHE MIT VORSATZSCHIENE
EN	CAKE DISPLAY SHEET WITH JOINT BAR
IT	TEGLIE PER TORTE CON BORDO REMOVIBILE
ES	BANDEJAS CON LATERAL DESMONTABLE

**GN 1/1 mit Vorsatzschiene**

- Innenabmessungen: 520 x 290 x 50 mm
- Außenabmessungen: 535 x 325 x 50 mm

**GN 1/1 with joint bar**

- Dimensions inside: 520 x 290 x 50 mm
- Dimensions outside: 535 x 325 x 50 mm

#		
994860	<b>Edelstahl</b> / stainless steel	
995860	<b>Aluminium</b> / aluminium	



GN 1/1

# 994860

2



DE	BACKBLECHVORSETZER	
EN	JOINT BAR, ADJUSTABLE	SST
IT	SPONDA REGOLABILE	
ES	BARRA AJUSTABLE	

- Mit 2 Klammern
- With 2 clamps

#	Ausführung	↔ mm
997899	Feder / Spring	340 min. / 615 max
997890	Klammer / Clamp	340 min. / 640 max



# 997899



# 997890

DE	SCHNITTKUCHEN – BODENBLECH UND BACKRAHMEN IM SET	
EN	CAKE DISPLAY – BASE PLATE AND BAKING FRAME IN THE SET	ALU
IT	KIT DI TEGLIA PER TORTA CON FONDO E TELAIO SEPARATI	
ES	JUEGO DE PLACA BASE Y MARCO PARA HORNEAR	

- **2-teilig**
- Materialstärke: Boden mit Griff: 1,5 mm, Rahmen: 2,0 mm
- **2-pieces**
- Thickness: base with handle: 1.5 mm, frame: 2.0 mm

#	↗ mm	→ mm	↑ mm
995870	580	100	50
995880	580	200	50
995890	580	400	50



# 995880

NICHT zum Backen geeignet!  
NOT for baking!



DE	RAHMEN FÜR SCHNITTKUCHENBLECH	
EN	FRAME FOR CAKE DISPLAY SHEET	PS
IT	BASE PER TEGLIE PORTA TORTE	
ES	CONTENEDORES DE BANDEJAS PARA TORTA	

- Schwarz
- Genarbt
- Eine kurze Seite offen
- Black
- Surface grained
- One short side open

#	für/for #	→ mm	↑ mm	↓ mm	
227577	995810 + 997810	115	55	590	
227578	995820 + 997820	215	55	590	



DE	PRÄSENTIER-STÄNDER / SCHNITTKUCHENBRÜCKE	
EN	DISPLAY RISER FOR SLICED CAKES	AC
IT	ALZATA ESPOSITORE PER TORTE A FETTE	
ES	SOPORTE PARA REBANADAS DE PASTELES	

- Transparent
- Transparent

#	für/for #	→ mm	↑ mm	↓ mm	
227575	995810 + 997810	106	80	70	
227576	995820 + 997820	206	80	70	



DE	GASTRO-BLECH UNIVERSAL	
EN	GASTRO-TRAY UNIVERSAL	ALU GN 1/1 
IT	VASSOIO DA FORNO GASTRO UNIVERSAL	
ES	BANDEJA DE COCCIÓN GASTRO UNIVERSAL	

- Für Spiegeleier, Omeletts, Tortillas, Hamburger
- Mit TYNECK-Beschichtung
- 6 Mulden
- For fried eggs, omelets, tortillas, hamburgers
- With TYNECK-coating
- 6 cavities

#	↔ mm	Ø mm	
382325	325 x 530	120	



DE	BAGUETTEBLECHE	
EN	BAGUETTE TRAYS	ALU
IT	TEGLIE PER BAGUETTE	
ES	BANDEJAS PARA BAGUETTES	

- Ausführung: offener Rand – längs**
- Mit PTFE-Beschichtung, schwarz
  - Perforation: 3 mm
  - Runde Wellen
- Design: open edge – long side**
- With PTFE-coating, black
  - Perforation: 3 mm
  - Round waves

#	↔ mm	∓ mm	Mulden / Cavities	
381430	600 x 400 x 20	1,5	5	
381432	530 x 325 x 20	1,5	4	

GN 1/1

DE	BACKTRENNPAPIERE "RONDEN" UND "RINGREIN"
EN	BAKING RELEASE PAPERS "RONDEN" (DISCS) AND "RINGREIN"
IT	CARTA DA FORNO, DISCHI E NASTRI
ES	PAPEL DE HORNO, CINTAS Y HOJAS REDONDAS

- |                            |                             |
|----------------------------|-----------------------------|
| • Gebleicht                | • Bleached                  |
| • Beidseitig silikonisiert | • Siliconized on both sides |
| • Mehrmals verwendbar      | • Multiple bakes            |

#	Ø mm	
101007	70 mm x 400 m	1



# 101007

2



#	Ø mm	
101006	180	500
101005	200	500
101011	240	500
101001	260	500
101002	280	500
101003	300	500
101004	330	500
101000	350	500





Einfache Entnahme aus dem Karton / Easy removal

DE	PERGAMENTERSATZ
EN	GREASEPROOF PAPER
IT	CARTA PERGAMINO
ES	HOJAS DE PAPEL PERGAMINO

- |   |   |
|---|---|
| • Gebleicht   | • Bleached                                      |
| • Unbeschichtet   | • Uncoated                                      |
| • Zum Abdecken von Teiglingen oder als Einlegepapier für Brotkörbe verwendbar | • To cover dough or usable as inlay for baskets |

#	↔ mm x mm	 g/m <sup>2</sup>	 kg
111300	380 x 580	45	10
111400	360 x 560	41	12,5
111410	375 x 500	49	12,5
111420	250 x 375	49	12,5
111430	500 x 750	49	12,5

#	↔ mm	 g/m <sup>2</sup>	 kg
111440	300	49	9
111441	400	49	12
111442	500	49	15
111443	600	49	18



 Sonderformate auf Anfrage. / Special sizes upon request.



DE	BACKTRENNPAPIERE
EN	BAKING RELEASE PAPERS
IT	CARTA DA FORNO
ES	PAPEL DE HORNO SILICONADO

- |   |  |
|---|--|
| <ul style="list-style-type: none"> <li>• Echtpergament</li> <li>• Gebleicht</li> <li>• Beidseitig silikonisiert</li> <li>• Mehrmals verwendbar</li> <li>• Hitzebeständig bis zu 290 °C</li> <li>• Hohe Fettdichte</li> <li>• Geeignet für alle Gebäckarten</li> </ul> | <ul style="list-style-type: none"> <li>• Pure vegetable parchment</li> <li>• Bleached</li> <li>• Siliconized on both sides</li> <li>• Reusable</li> <li>• Heat resistant up to 290 °C (554 °F)</li> <li>• High grease density</li> <li>• Suitable for all types of pastry</li> </ul> |
|---|--|



**“NON PLUS ULTRA”**

**“NON PLUS ULTRA”**

#	↔ mm x m	⚖ g/m <sup>2</sup>	🛒
101040	400 x 200	45	6
101043	430 x 200	45	6
101045	450 x 200	45	6
101050	500 x 200	45	6
101057	570 x 200	45	6

#	↔ mm	⚖ g/m <sup>2</sup>	🛒
101100	400 x 600	45	500
101120	500 x 700	45	500
101140	570 x 780	45	500



**“UNIVERSAL PLUS”  
Speziell für Laugenprodukte**

**“UNIVERSAL PLUS”  
Especially for lye baking products  
including “pretzels”**

#	↔ mm	⚖ g/m <sup>2</sup>	🛒
109100	400 x 600	42	500
109140	570 x 780	42	500

Sonderformate auf Anfrage. / Special sizes upon request.

DE	BACKTRENNPAPIERE
EN	BAKING RELEASE PAPERS
IT	CARTA DA FORNO
ES	PAPEL DE HORNO SILICONADO

- Pergamentersatz
- Gebleicht
- Beidseitig silikonisiert
- Mehrmals verwendbar
- Greaseproof
- Bleached
- Two sides siliconized
- Multiple bakes

**“SUPER EXTRA”**

**“SUPER EXTRA”**

#	↔ mm x m	g/m <sup>2</sup>	
103040	400 x 200	41	6
103043	430 x 200	41	6
103045	450 x 200	41	6
103050	500 x 200	41	6
103057	570 x 200	41	6

#	↔ mm x mm	g/m <sup>2</sup>	
103079	340 x 430	41	500
103001	390 x 590	41	500
103100	400 x 600	41	500
103141	500 x 700	41	500
103140	570 x 780	41	500
103150	570 x 980	41	500

103032	325 x 530	<b>GN 1/1</b>	41	500
103078	520 x 640	<b>GN 2/1</b>	41	500



GN 1/1

GN 2/1

**“UNIVERSAL”  
Speziell für Laugenprodukte**

**“UNIVERSAL”  
Especially for lyed baking products  
including “pretzels”**

#	↔ mm x mm	g/m <sup>2</sup>	
106152	400 x 600	41	500
106140	570 x 780	41	500



**“SUPER CLASSIC”**

**“SUPER CLASSIC”**

#	↔ mm x m	g/m <sup>2</sup>	
104057	570 x 200	39	6

#	↔ mm x mm	g/m <sup>2</sup>	
104100	400 x 600	39	500
104140	570 x 780	39	500

104032	325 x 530	<b>GN 1/1</b>	39	500
--------	-----------	---------------	----	-----

GN 1/1

**NEW**

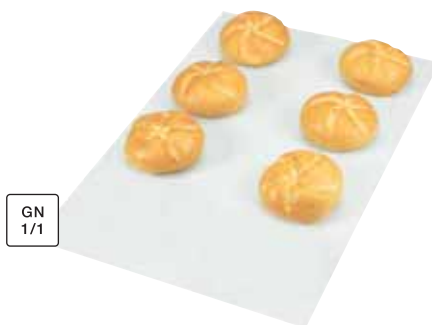



# 202090



DE	FAHRGESTELL FÜR BACKTRENNPAPIER	<b>SST</b>
EN	TROLLEY FOR BAKING RELEASE PAPERS	
IT	CARRELLO PER CARTA DA FORNO	
ES	CARRETILO PARA PAPEL DE HORNO	

- Inklusive 4 Rollen
- Für je 1000 Blatt
- Including 4 wheels
- For 1000 sheets

#	↖ mm	→ mm	↓ mm	↑ mm	
202090	400 x 600	500	370	730	
202091	570 x 780	650	370	920	



# 159150 + 159160



# 159240 + 159250 + 159260



# 159350 + 159360

DE	ABREISSGERÄTE
EN	TEAR-OFF DISPENSERS
IT	PORTAROTOLI DA TAVOLO
ES	SOPORTES PARA ROLLOS DE PAPEL SILICONADO

- Praktische Einhandbedienung dank hoher Standfestigkeit
- Lackierter Stahlprofilrahmen
- Glatte Schiene für Papier / Folienrollen von 30 bis 100 cm Breite und 22 cm Durchmesser, max. 20 kg
- Practical single-hand operation thanks to highly stable design
- Lacquered steel profile frame
- Smooth bar for paper / film rolls measuring from 30 to 100 cm in width and 22 cm in diameter, max. 20 kg

#	→ mm	
159150	500	Tisch, waagrecht / table, horizontal
159160	600	Tisch, waagrecht / table, horizontal
159240	400	Wand, waagrecht / wall, horizontal
159250	500	Wand, waagrecht / wall, horizontal
159260	600	Wand, waagrecht / wall, horizontal
159350	500	Tisch, senkrecht / table, vertical
159360	600	Tisch, senkrecht / table, vertical
159450	500	Untertisch, waagrecht /
159460	600	under table, horizontal



# 159450 + 159460

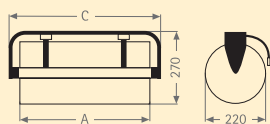

Untertisch, waagrecht / under table, horizontal

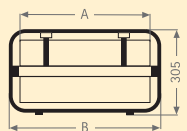

Tisch, waagrecht / table, horizontal

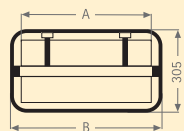
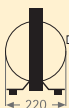

Wand, waagrecht / wall, horizontal

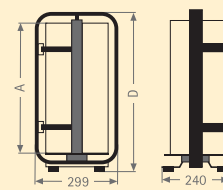

Tisch, senkrecht / table, vertical

DE	BACKTRENNFOLIE AUS PTFE-GLASGEWEBE
EN	BAKING FOIL MADE OF PTFE-COATED GLASS FABRIC
IT	CARTA DA FORNO IN TESSUTO IN FIBRA DI VETRO RIVESTITO IN PTFE
ES	LAMINA DE TEFLÓN (PTFE) ANTIADERENTE PARA HORNO

Antihaftend (PTFE-beschichtetes Glasfasergewebe)

- Hervorragende Trenneigenschaften
- Reißfest
- Temperaturbeständig von -70 °C bis +260 °C
- Beidseitig verwendbar
- Geschmacksneutral
- Spülmaschinenfest
- Bis zu 1.000 x verwendbar (bei sachgerechter Anwendung)

Non-stick quality (PTFE coated glass fabric)

- Tear-resistant
- Usuable from -70 °C to +260 °C
- Usable on both sides
- Neutral in taste
- Dishwasher-proof
- Reusable up to 1.000 times (if used properly)

**Farbe: braun**

**Color: brown**

#	↔ mm	⏊ mm	⚖ g/m <sup>2</sup>	🛒
110110	330 x 400	0,073	120	20
110108	400 x 500	0,073	120	20
110500	400 x 600	0,073	120	20
110520	500 x 700	0,073	120	20
110540	570 x 780	0,073	120	20
110550	570 x 980	0,073	120	20
110562	600 x 800	0,073	120	20
110116	325 x 530	0,11	220	20
110100	400 x 600	0,11	220	20
110140	570 x 780	0,11	220	20
110150	570 x 980	0,11	220	20
110700	400 x 600	0,215	445	20
110720	570 x 780	0,215	445	20
110740	570 x 980	0,215	445	20



GN 1/1

**i** Sonderformate auf Anfrage. / Special sizes upon request.

**Auf Rolle**

**On a roll**

#	→ mm	↑ Meter	⏊ mm
110940	400	50	0,11
110957	570	50	0,11



DE	ABROLLGERÄT	<b>PVC</b>
EN	DISPENSER	
IT	DISTRIBUTORE	
ES	DISPENSADOR	

#	↔ mm
391980	890 x 140 x 100





# 107782



# 107784



# 107791



DE	BACK- UND TIEFKÜHLMATTEN
EN	BAKING AND FREEZER MATS
IT	TAPPETI DA FORNO E DA CONGELATORE IN SILICONE
ES	ESTERAS PARA HORNEAR Y CONGELAR

Material: silikonbeschichtetes Glasfasergewebe

- Sehr robust
- Temperaturbeständig von -40 °C bis +230 °C
- Vorzügliche Antihafffähigkeit
- Vorteilhaft in Verbindung mit Lochblechen

Made of siliconized glass fibre fabric

- Very strong quality
- Usable from -40 °C to +230 °C
- Excellent non-stick quality
- Recommended to be used in combination with perforated baking trays

**Especially for lyed baking products including "pretzels"**

**Speziell für Laugenprodukte**

#	↔ mm	für/for mm
107785	315 x 520	325 x 530 (GN 1/1)
107782	385 x 585	400 x 600
107783	570 x 770	580 x 780

**i** Sonderformate auf Anfrage. / Special sizes upon request.

**Silikonmatte Macarons**

- Einteilung Ø: 35 mm

**Silicon mat for macarons**

- Division Ø: 35 mm

#	↔ mm
107784	300 x 400

**Material: 100% Silikon**

**Made of 100% silicone**

#	↔ mm
107790	310 x 510
107791	400 x 600

**Silikonmatte Macarons**

- Einteilung Ø: 40 mm

**Silicon mat for macarons**

- Division Ø: 40 mm

#	↔ mm	↑ mm
115165	400 x 600	1,5

DE	BACKTRENNSPRAY	
EN	RELEASE SPRAY	
IT	SPRAY STACCANTE ANTIADERENTE	
ES	DESMOLDEANTE EN SPRAY	

Das perfekte Trennspray für Bäckereien, Konditoreien, Küchen und Gastronomie. Speziell für WALTER-Backformen geeignet. Kein Anbacken oder Ankleben der Backwaren; keine Rückstände in der Form oder auf dem Blech. Reines Lebensmittel, 100 % geschmacksneutral. Zutaten: Pflanzliche Öle  
 Verdickungsmittel: Carnaubawachs  
 Emulgator: Sonnenblumenlecithine  
 Treibgas: Butan / Isobutan / Propan  
**Nur zur gewerblichen Verarbeitung. Nicht für Luftfracht zugelassen.**

The ideal release spray for bakeries, confectioneries, hotel and restaurant kitchens. Especially suitable for WALTER baking moulds. No caking or sticking of the baked goods; no residues in the mould or on the tray. 100 % safe for consumption and tasteless.  
 Ingredients: vegetable oils  
 Thickener: carnauba wax  
 Emulsifier: sunflower lecithin  
 Propellant: butane / isobutane / propane  
**Only for professional use. Not permitted for transport via airfreight.**

#	ml	↑
266960	500	Butan / Isobutan / Propan

DE	MUFFINFORMEN-VERBUND „TULPE“	
EN	MUFFIN TRAYS “TULIP”	<b>ALU</b>
IT	PORTA PIROTTINI MUFFIN "TULIPANO"	
ES	PLACA DE ALUMINIO PARA MUFFINS “TULIPA”	

- |  |   |
|--|---|
| <ul style="list-style-type: none"> <li>• Für 24 Muffinformen „TULPE“</li> <li>• Ø: 70 mm</li> <li>• Gewicht: 1400 g</li> </ul> | <ul style="list-style-type: none"> <li>• For 24 Muffin baking cups “TULIP”</li> <li>• Ø: 70 mm</li> <li>• Weight: 1400 g</li> </ul> |
|--|---|



#	↔ mm	
381150	600 x 400 x 40	

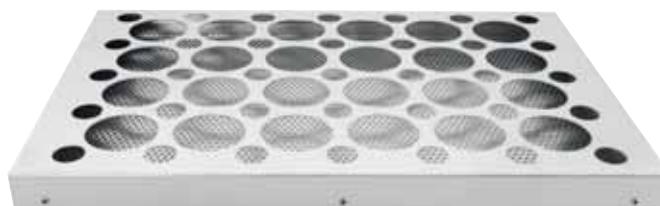

DE	MUFFINFORMEN-VERBUND „TULPE“	
EN	MUFFIN TRAYS “TULIP”	<b>ALU</b>
IT	PORTA PIROTTINI MUFFIN "TULIPANO"	
ES	PLACA DE ALUMINIO PARA MUFFINS “TULIPA”	

- |   |   |
|---|---|
| <ul style="list-style-type: none"> <li>• Für 24 Muffinformen „TULPE“</li> <li>• Ø: 70 mm</li> </ul> | <ul style="list-style-type: none"> <li>• For 24 Muffin baking cups “TULIP”</li> <li>• Ø: 70 mm</li> </ul> |
|---|---|

#	↔ mm	
381151	580 x 390 x 38	



DE	MUFFINFORMEN-VERBUND „TULPE“	
EN	MUFFIN TRAYS “TULIP”	<b>ALU</b>
IT	PORTA PIROTTINI MUFFIN "TULIPANO"	
ES	PLACA DE CARTON PARA MUFFINS “TULIPA”	

- |  |  |
|--|--|
| <p>Material: backfester Wellpappkarton</p> <ul style="list-style-type: none"> <li>• Für 24 Muffinformen</li> </ul> | <p>Made of bakeable cardboard</p> <ul style="list-style-type: none"> <li>• For 24 Muffin cups</li> </ul> |
|--|--|

#	↔ mm		
122260	580 x 390 x 35		42



DE	MUFFINFORM TULPE
EN	MUFFIN CUPS TULIP
IT	PIROTTINI PER MUFFIN TULIPANO
ES	CÁPSULAS PARA MUFFINS TULIPA

Material: Reines Zellulose Papier

- Hitze- und fettbeständig
- Hitzebeständigkeit: 180 – 200 °C (1h)

Made of pure cellulose paper

- Heat and grease resistant
- Heat resistance: 180 – 200 °C (1h)



#		↓ Ø mm	↑ mm	
122250	● braun / brown	50	95	1000
122270	● braun / brown	50	55	1000
122271	● rot / red	50	55	1000
122272	● gelb / yellow	50	55	1000
122273	● blau / blue	50	55	1000
122274	● violett / lila	50	55	1000
122275	● grün / green	50	55	1000
122276	● orange / orange	50	55	1000
122277	● pink / pink	50	55	1000



DE	GEBÄCKKAPSELN
EN	BAKING CASES
IT	PIROTTINI MARRONI
ES	CÁPSULAS MARRONES

Aus Pergamyn, schokobraun

- Backfest

Made of glassine, chocolate brown

- Bakeable



#	↓ Ø mm	↑ mm	
156008	70	30	1000

Aus Pergamentersatz, weiß

- Backfest

Made of greaseproof paper, white

- Bakeable



#	↓ Ø mm	↑ mm	
122024	25	18	1000
122035	35	20	1000
122040	40	21	1000
122045	45	25	1000
122050	50	25	1000
122055	55	25	1000
122060	60	25	1000
122065	65	22	1000
122070	70	20	1000
122075	75	21	1000
122080	80	25	1000

DE	MUFFINFORMEN-VERBUND
EN	MUFFIN TRAYS
IT	PORTA PIROTTINI PER MUFFIN
ES	CAPSULAS PARA MUFFINS EN PLACAS



- Perforiert – leichte Entnahme
- Höhe: 35 mm
- Perforated – easy to remove
- Height: 35 mm

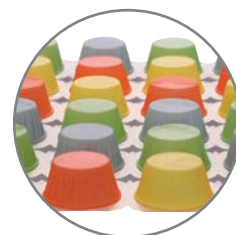

#	↑ Ø mm	↓ Ø mm	↔ mm	g	
122100	68	50	338 x 504	2 OZ ca. / 50	125 trays
122105	68	50	338 x 504	2 OZ ca. / 50	100 trays
122110	80	63	385 x 575	4 OZ ca. / 100	125 trays



# 122100



# 122105



# 122110

DE	BACKFORM "KÖNIGSKUCHEN"
EN	LOAF CAKE BAKING MOULD
IT	STAMPO "PLUMCAKE"
ES	MOLDE "PLUMCAKE"

- Material: backfestes zweilagiges Papier
- 150 g/m<sup>2</sup>
  - Temperaturbeständig von -40°C bis +220°C
- Made of bakeable paper, two layers
- 150 g/m<sup>2</sup>
  - Temperature resistant from -40°C to +220°C

#	↗ mm	→ mm	↑ mm	g	
122400	150	65	50	200	1080
122410	200	65	45	300	600
122420	225	70	65	400	516
122430	260	65	50	500	504



# 122410

DE	BACKFORMEN RUND
EN	BAKING MOULDS ROUND
IT	STAMPI TONDI PER TORTE
ES	MOLDES PARA TARTA

- Material: backfestes zweilagiges Papier
- 125 g/m<sup>2</sup>
  - Temperaturbeständig von -40°C bis +220°C
- Made of bakeable paper, two layers
- 125 g/m<sup>2</sup>
  - Temperature resistant from -40°C to +220°C

#	Ø mm	↑ mm	
122700	100	30	450
122720	155	35	540
122740	185	30	600
122780	220	40	500



# 122740

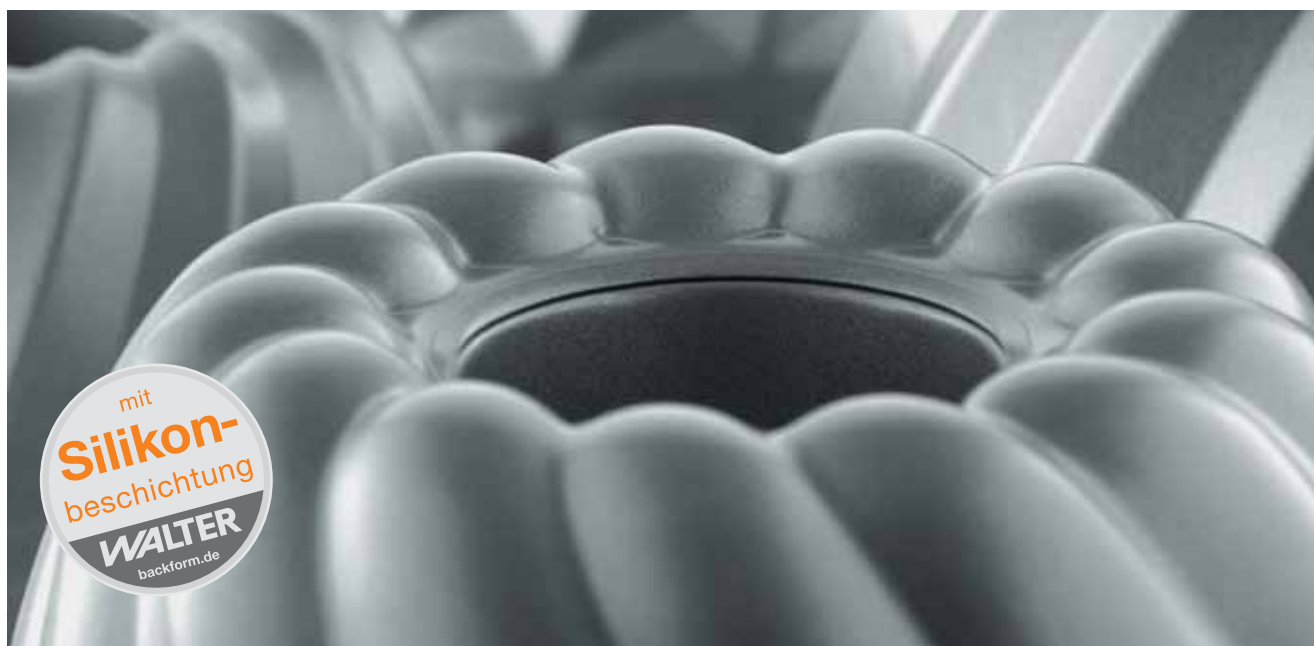

#### PREMIUM-QUALITÄT ANTIHAFT

- Spezielle Antihaf-Beschichtung
- Erhöhung der Verschleißfestigkeit durch Einsatz keramischer Partikel
- Besonders schwere Profi-Qualität
- Optimale Wärmeleitung
- Gleichmäßiges Backen
- Obstsäurebeständig

Bitte beachten:

- Alle Backformen bitte grundsätzlich einfetten (kein Öl verwenden)!
- Form nicht mit spitzen und scharfen Gegenständen behandeln
- Kuchen 5 –10 Min. auskühlen lassen, dann gleich aus der Form lösen
- Schnelle und einfache Reinigung: mit einem Tuch und heißem Wasser unter Zusatz eines handelsüblichen Spülmittels auswaschen
- Zur Schonung der Beschichtung keine Reinigung in der Spülmaschine
- Form nicht im Froster verwenden
- Nicht für Holzbacköfen geeignet
- Einsetzbar bis ca. +200 °C
- Zur Schonung der Beschichtung – Formen bitte nicht ohne Schutz stapeln

#### PREMIUM-QUALITY NON-STICK

- Outstanding anti-stick properties
- Wear-resistant by special coating using ceramic particles
- Particularly heavy professional quality
- Excellent thermal conductivity
- Intensive and all around browning
- Acid resistant

Please notice:

- All baking moulds must be buttered (please do not use oil)!
- Never use pointed or sharp utensils
- Let cake cool down for 5 –10 minutes, then loosen cake out of the mould right away
- Easy cleaning: with a damp cloth, mild detergent and hot water
- Not dish-washer proof
- Not useable in the freezer
- Not useable in wood-fired ovens
- Useable up to +200 °C
- To protect the coating – please do not stack baking moulds without protection

DE	RODONFORM – MIT GLATTEM RAND
EN	RODON MOULD – WITH PLAIN RIM
IT	STAMPO AMERICANO – CON BORDO LISCIO
ES	MOLDE RODON – CON BORDE LISO



#	Ø mm	↑ mm	
901314	140	72	0,6
901316	160	85	1,0
901318	180	95	1,4
901320	200	105	1,8
901322	220	115	2,2
901324	240	125	2,9
901326	260	135	3,8



#901314



3

DE	GUGELHUPF-FORM
EN	GUGELHUPF MOULD
IT	STAMPO PER GUGELHUPF
ES	MOLDE PARA GUGELHUPF



#	Ø mm	↑ mm	
930020	200	104	1,8



DE	SANDKRANZFORM – MIT GLATTEM BODEN
EN	SAVARIN RING MOULD – WITH PLAIN BOTTOM
IT	STAMPO SAVARIN – FONDO LISCIO
ES	MOLDE PARA SAVARIN – FONDO LISO



#	Ø mm	↑ mm	
926820	200	65	1,45
926822	220	70	1,80
926824	240	77	2,25
926826	260	82	3,00
926828	280	89	3,70



#926820



DE	FRANKFURTER KRANZFORM - MIT GERIPPTEM BODEN
EN	SAVARIN RING MOULD – WITH WAVY BOTTOM
IT	STAMPO TROIS FRERES – FONDO FESTONATO
ES	MOLDE PARA SAVARIN – FONDO RIZADO



#	Ø mm	↑ mm	
915120	200	65	1,35
915122	220	70	1,85
915124	240	77	2,35
915126	260	82	2,95
915128	280	89	3,60



#915120





**WALTER**  
...einfach besser backen...

DE	KÄSETORTENFORM – MIT GERADEM RAND	
EN	CHEESE FLAN PAN – WITH STRAIGHT RIM	
IT	TORTIERA TONDA – CON BORDO LISCIO	
ES	MOLDE REDONDO – CON BORDE DERECHO	

#	Ø mm	↑ mm	↓ mm	↑ mm
967028	280	40		2,30



#900020

**WALTER**  
...einfach besser backen...

DE	SPRINGFORM	
EN	SPRINGFORM CAKE TIN	
IT	STAMPO APRIBILE	
ES	MOLDE DESMONTABLE PARA TARTA	

- Verschluss aus rostfreiem Edelstahl
- Quick release clasp made of stainless steel

#	Ø mm	↑ mm	↓ mm	↑ mm
900020	200	70		2,15
900024	240	70		3,00
900026	260	70		3,50
900028	280	70		4,05



DE	TEIGSCHABER / KUCHENLÖSER	<div style="border: 1px solid black; padding: 2px; display: inline-block;">PP</div>
EN	DOUGH SCRAPER	
IT	SPATOLA	
ES	ESPÁTULA	

- Weiß
- Ideal fürs Kuchenlösen in beschichteten Backformen
- White
- Ideal for loosing cakes in coated baking moulds

#	↗ mm	→ mm	↑ mm
227099	220	35	6



#902028

**WALTER**  
...einfach besser backen...

DE	SPRINGBLECH – KONISCH	
EN	SPRINGFORM CAKE TIN – CONICAL	
IT	STAMPO APRIBILE – CONICO	
ES	MOLDE CONICO DESMONTABLE PARA TARTA	

- Verschluss aus rostfreiem Edelstahl
- Quick release clasp made of stainless steel

#	↑ Ø mm	↓ Ø mm	↑ mm	↓ mm
902028	280	260	60	3,30
902032	320	300	60	4,35

 Zur Schonung der Beschichtung – Formen bitte nicht ohne Schutz stapeln.  
To protect the coating – please do not stack baking moulds without protection.



DE	KUCHENBLECH
EN	CAKE MOULD
IT	TORTIERA TONDA
ES	MOLDE REDONDO



#	↑ Ø mm	↓ Ø mm	↑ mm	l	
904024	240	200	35	1,30	
904026	260	220	35	1,50	
904028	280	240	35	1,80	
904030	300	260	35	2,10	
904032	320	280	35	2,40	
904034	340	300	35	2,75	
904036	360	320	35	3,05	



#904024



3

DE	PIZZABLECH
EN	PIZZA MOULD
IT	STAMPO PER PIZZA
ES	MOLDE PARA PIZZA



#	↑ Ø mm	↓ Ø mm	↑ mm	l	
904524	240	210	25	0,90	
904526	260	235	25	1,10	
904528	280	250	25	1,25	



#904524



Nicht für Holzbacköfen geeignet! / Not suitable for wood-fired ovens!

DE	OBSTTORTENFORM – MIT GERIPPTEM RAND UND GEPRÄGTEM BODEN
EN	FRUIT FLAN PAN - WITH FLUTED RIM AND STAMPED BOTTOM
IT	STAMPO PER CROSTATE DI FRUTTA CON BORDO FESTONATO E FONDO GOFFRATO
ES	MOLDE PARA TARTA DE FRUTAS CON BORDE RIZADO Y FONDO GOFRADO



#	↑ Ø mm	↓ Ø mm	↑ mm	l	
949928	280	253	32	1,50	
949930	300	273	32	1,70	
949932	320	293	32	1,80	



#949928



DE	KÖNIGSKUCHENFORM
EN	LOAF CAKE MOULD
IT	STAMPO PER PLUMCAKE
ES	MOLDE PLUMCAKE



#	→ mm	↗ mm	↑ mm	l	
910020	90	200	70	1,05	
910025	100	250	70	1,45	
910030	110	300	79	2,15	
910035	120	350	85	3,00	



#910020





#940025

**WALTER**  
...einfach besser backen...

DE	HERZFORM
EN	HEART MOULD
IT	STAMPO CUORE
ES	MOLDE CORAZÓN



#	→ mm	↑ mm	⊥ mm
940025	250	61	2,60
940027	270	65	3,30



**WALTER**  
...einfach besser backen...

DE	WOLFSZAHNBLECH
EN	DENTS DE LOUP BISCUITS BAKING SHEET
IT	TEGLIA PER BISCOTTI "DENTI DI LUPO"
ES	PLACA PARA "DIENTES DE LOBO"



#	↗ mm	→ mm
920000	350	330



#994628

**WALTER**  
...einfach besser backen...

DE	REHRÜCKENFORM
EN	RIDGED BAKING MOULD
IT	STAMPO AMOR POLENTA
ES	MOLDE MEDIA CAÑA REDONDO ONDULADO



#	→ mm	↗ mm	↑ mm	⊥ mm
994628	110	280	60	1,35
994633	110	330	60	1,60



DE	QUICHE-FORM
EN	"QUICHE" MOULD
IT	STAMPO QUICHE
ES	MOLDE QUICHE



- Mit praktischem Auslöseboden
- With removable bottom

#	↑ Ø mm	↑ mm	↓ mm	↑ mm
901050	300	30	1,80	



3

DE	WEIHNACHTSSTERN-FORM
EN	CHRISTMAS STAR MOULD
IT	STAMPO "STELLA DI NATALE"
ES	MOLDE "ESTRELLA DE NAVIDAD"



#	→ mm	↓ mm	↑ mm	↑ mm
967040	150	340	65	2,25



DE	BRIOCHEFORM
EN	BRIOCHE MOULD
IT	STAMPI A BRIOCHE
ES	MOLDES BRIOCHE



#	Ø mm	↑ mm	↑ mm
951012	120	45	0,25
951014	140	50	0,43
951016	160	60	0,63



DE	HERZFORM MIT GERIPPTEM RAND
EN	FLUTED HEART MOULD
IT	STAMPO CUORE FESTONATO
ES	MOLDE CORAZON RIZADO



#	↔ mm	↑ mm	↑ mm
967075	270	30	1,3





**WALTER**  
...einfach besser backen...

DE	12-MUFFINFORM	
EN	12-CUP MUFFIN PAN	
IT	STAMPO PER 12 MUFFIN	
ES	MOLDE PARA 12 MUFFINS	

#	Formen	ml	↔ mm	Ø mm
960020	12	90	370 x 242 x 30	62



**WALTER**  
...einfach besser backen...

DE	MADELEINE	
EN	MADELEINE	
IT	MADELEINE	
ES	MADELEINE	

Material: Stahl

Made of carbon steel

#	Formen / cavities (mm)	↔ mm
967065	12 (55 x 44)	350 x 145 x 15
967070	12 (77 x 52)	405 x 195 x 19



**WALTER**  
...einfach besser backen...

DE	FUSSBALLFORM	
EN	FOOTBALL MOULD	
IT	STAMPO PALLONE DA CALCIO	
ES	MOLDE BALÓN DE FÚTBOL	

#	Ø mm	h mm
967050	225	2,75



**WALTER**  
...einfach besser backen...

DE	FUSSBALLFELD	
EN	FOOTBALL FIELD	
IT	STAMPO DA CAMPO DI CALCIO	
ES	MOLDE CAMPO DE FÚTBOL	

#	↔ mm	h mm
967060	350 x 245	3,6



DE	LAMM-FORM
EN	LAMB MOULD
IT	STAMPO "AGNELLO"
ES	MOLDE "EL BORREGO"

Material: vorbehandelter Stahl  
 • Mit Antihafbeschichtung  
 • Inkl. 2 Klammern

Made of precoated steel  
 • With non-stick coating  
 • Incl. 2 clips

**KLEIN / Kopf seitwärts**

**SMALL / Head turned to the left**

#	→ mm	↓ mm	↑ mm	⊥	
968000	163	67	108	0,5	



3

**GROSS / Kopf gerade**

**LARGE / Head pointing straight ahead**

#	→ mm	↓ mm	↑ mm	⊥	
968010	245	80	160	1,0	



DE	STÄNDER ZUM BEFÜLLEN DER LAMMFORMEN
EN	STAND FOR FILLING LAMB CAKE MOULDS
IT	SUPPORTO PER IL RIPIPIAMENTO DEGLI STAMPI "AGNELLO"
ES	SOPORTE MOLDES "EL BORREGO"

Material: Edelstahl ohne Beschichtung

Made of stainless steel without coating

#	→ mm	↗ mm	für/for #	
				für kleines Lamm / for small lamb
968020	167	376	968000	
				für großes Lamm / for large lamb
968030	250	500	968010	

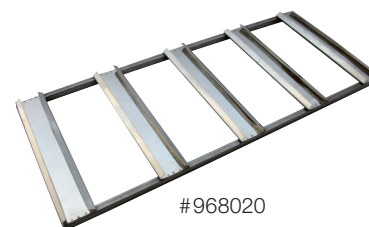

#968020

DE	LAMMFORM-SET
EN	SET OF LAMB MOULDS
IT	SET DI STAMPO "AGNELLO"
ES	JUEGO DE MOLDES "EL BORREGO"

**SET**

• Komplet mit 5 Lämmern,  
 1 Ständer und 10 Klammern

• Consisting of 5 large lambs,  
 1 stand and 10 clips

#		⊥	
968040	klein / small	0,5	
968050	gross / large	1,0	





**PREMIUM-QUALITÄT EMAILLIERT**

- Quarz-Emaille-Beschichtung
- Schnitt- und kratzfest
- Obstsäurebeständig

Alle Backformen bitte grundsätzlich einfetten (kein Öl verwenden)!

Bitte beachten:

- Form leicht einfetten
- Kuchen 5 – 10 Min. auskühlen lassen, dann gleich aus der Form lösen
- Schnelle und einfache Reinigung: mit einem Tuch und heißem Wasser unter Zusatz eines handelsüblichen Spülmittels auswaschen
- Form nicht im Froster verwenden

**PREMIUM-QUALITY ENAMEL**

- Quarz-enamel coated surface
- Cut- and scratch resistant
- Acid resistant

All baking moulds must be buttered (please do not use oil)!

Please notice:

- Butter mould slightly
- Let cake cool down for 5 – 10 minutes, then loosen cake out of the mould right away
- Clean immediately with warm water and dry thoroughly
- Do not use moulds in the freezer



#981040



DE	KUCHENBLECH
GB	CAKE MOULD
IT	TORTIERE TONDE, SMALTATE
ES	MOLDE REDONDO, ESMALTADO



Emailliert, schnittfest, Farbe schwarz  
max. +300 °C

Enamel, cut proof, color black  
max. +300 °C

#	↑ Ø mm	↑ mm	↑ mm	↑ mm
981040	300	35	2,05	
981041	320	35	2,35	



#912030



DE	KASTENFORM/BROTBACKFORM
GB	BREAD MOULD
IT	STAMPI DA PANE
ES	MOLDE PARA PAN



Emailliert, schnittfest, Farbe schwarz,  
max. +300 °C

Enamel, cut proof, color black,  
max. +300 °C

#	→ mm	↗ mm	↑ mm	↑ mm
912030	110	300	79	2,15
912035	120	350	85	3,00





DE	STOLLENFORMENVERBAND	
EN	CHRISTSTOLLEN MOULD	ALU STEEL
IT	TEGLIA PER STOLLEN	
ES	MOLDE PARA STOLLEN	

- Ausführung: 4-teilig
- Inklusive Deckel
- Stahlblech aluminisiert
- Rückseite geschwärzt
- Geeignet für Stikkenofen
- Type: 4 pieces
- Including lid
- Sheet steel aluminized
- Back side blackened
- Suitable for baking trolley

#	↔ mm	→□← mm	g
154900	160 x 108 x 60	580 x 180	ca. 400
154901	230 x 100 x 70	580 x 250	ca. 500
154903	300 x 120 x 71	580 x 321	ca. 1000





#997976

DE	KUCHEN / QUICHE / FORMEN	ALU
EN	TART/QUICHE MOULDS	
IT	STAMPI QUICHE	
ES	MOLDES QUICHE	

- |  |  |
|--|--|
| <ul style="list-style-type: none"> <li>• <b>Mit herausnehmbarem Bodenteil</b></li> <li>• Rund gewellt</li> <li>• Materialstärke: 1 mm</li> </ul> | <ul style="list-style-type: none"> <li>• <b>With removable bottom</b></li> <li>• Round, wavy</li> <li>• Thickness: 1 mm</li> </ul> |
|--|--|

#	↑ Ø mm	↓ Ø mm	↑ mm
997976	280	260	25
997977	320	300	25



#997910



#997920

DE	KUCHENBLECH	ALU
EN	CAKE MOULD	
IT	TORTIERA TONDA	
ES	MOLDE REDONDO	

- |   |  |
|---|--|
| <ul style="list-style-type: none"> <li>• Materialstärke: 1 mm</li> <li>• Konisch</li> </ul> | <ul style="list-style-type: none"> <li>• Thickness: 1 mm</li> <li>• Conical</li> </ul> |
|---|--|

#	↑ Ø mm	↓ Ø mm	↑ mm
997910	300	260	40
997911	320	280	40
997912	340	300	40
997913	360	320	40
997914	380	340	40
997920	320	300	50
997921	340	320	50

DE	SANDKLANZFORM – MIT GLATTEM BODEN	ALU
EN	SAVARIN RING MOULD – WITH PLAIN BOTTOM	
IT	STAMPO SAVARIN – FONDO LISCIO	
ES	MOLDE PARA SAVARIN – FONDO LISO	

- Dom offen
- Mit gebördeltem Rand
- Open tube
- With rolled edge

#	Ø mm	↑ mm
997986	220	70
997987	240	80
997988	260	85



#997986

3

DE	KÖNIGSKUCHENFORM	ALU
EN	LOAF CAKE MOULD	
IT	STAMPO PER PLUMCAKE	
ES	MOLDE PLUMCAKE	

- Materialstärke: 1 mm
- Thickness: 1 mm

#	↗ mm	→ mm	↑ mm
997941	180	78	58
997942	220	90	65
997943	260	100	73
997944	300	105	73



#997943





**BACKFORMEN AUS SILIKON 300 x 175 mm**

Material: hochwertiges und lebensmittelechtes Silikon, mit Antihafwirkung – kein vorheriges Einfetten mehr notwendig!  
 Temperaturbereich: – 60 bis + 230 °C  
 (für Backöfen, Mikrowelle oder Gefrierschränke)  
 Größe der Backformen: 175 x 300 mm (GN1/3)

Bei richtiger Anwendung sind folgende Punkte zu beachten:

- Backgut immer abkühlen lassen
- Backformen niemals in direkten Kontakt mit Herdplatten, Feuer oder Grill bringen (am besten die Backformen auf Gitter oder Backbleche auflegen)
- Niemals das Backgut mit scharfen Gegenständen heraustrennen
- Niemals aggressive Reinigungsmittel verwenden, sondern von Hand reinigen

**BAKING MOULDS MADE OF SILICONE 300 X 175 mm**

Made of high quality, food safe and non-sticking silicone – without prior greasing!  
 Temperature range: from – 60 to + 230 °C  
 (for ovens, microwaves and freezers)  
 Size of the baking moulds: 175 x 300 mm (GN 1/3)

For optimal using please note the following points:

- Let cool down the products before extraction.
- Never use baking moulds on heat sources (fire, grill, electric plates)
- Never use sharp objects to remove your products from the moulds
- Never use aggressive detergents to clean moulds after use, just clean by hand

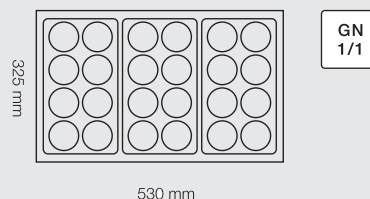
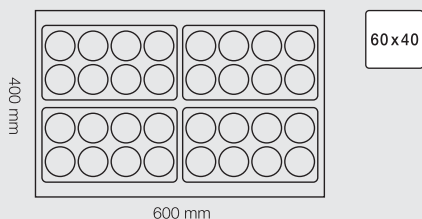

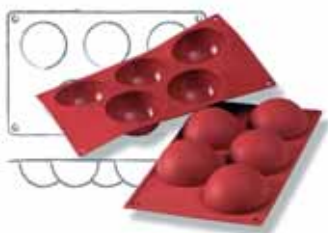

DE	HALBKUGELN
EN	HALF-SPHERES
IT	SEMISFERE
ES	SEMIESFERAS

<input checked="" type="checkbox"/> #	115003
Formen/cups	5 x 120 ml
Ø mm	80
↑ mm	40

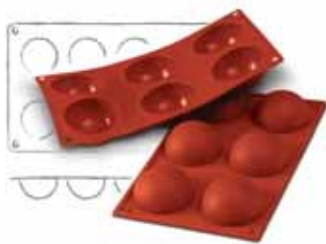

DE	HALBKUGELN
EN	HALF-SPHERES
IT	SEMISFERE
ES	SEMIESFERAS

<input checked="" type="checkbox"/> #	115005
Formen/cups	6 x 80 ml
Ø mm	70
↑ mm	35



DE	SAVARIN
EN	SAVARIN
IT	SAVARIN
ES	SAVARIN

<input checked="" type="checkbox"/> #	115007
Formen/cups	8 x 50 ml
Ø mm	65
↑ mm	21



DE	MUFFIN
EN	MUFFIN
IT	MUFFIN
ES	MUFFIN

<input checked="" type="checkbox"/> #	115011
Formen/cups	6 x 100 ml
Ø mm	69
↑ mm	35



DE	MUFFIN MINI
EN	MUFFIN MINI
IT	MUFFIN MINI
ES	MUFFIN MINI

<input checked="" type="checkbox"/> #	115012
Formen/cups	11 x 50 ml
Ø mm	51
↑ mm	28

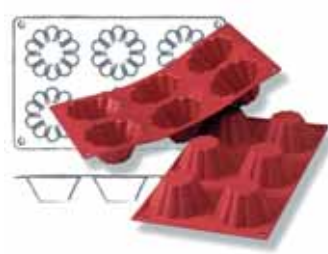

DE	BRIOCHE
EN	BRIOCHE
IT	BRIOCHE
ES	BRIOCHETTES

<input checked="" type="checkbox"/> #	115014
Formen/cups	6 x 110 ml
Ø mm	79
↑ mm	37



DE	TORTELETT
EN	TARTLET
IT	TARTELLETTA
ES	TARTALETA

<input checked="" type="checkbox"/> #	115016
Formen/cups	15 x 25 ml
Ø mm	50
↑ mm	15



DE	TORTELETT MINI
EN	TARTLET MINI
IT	TARTELLETTA MINI
ES	TARTALETA MINI

<input checked="" type="checkbox"/> #	115017
Formen/cups	15 x 20 ml
Ø mm	45
↑ mm	10



DE	PYRAMIDE
EN	PYRAMID
IT	PIRAMIDE
ES	PIRÁMIDE

<input checked="" type="checkbox"/> #	115028
Formen/cups	6 x 90 ml
↔ mm	71 x 71
↑ mm	40



DE	OVAL
EN	OVAL
IT	OVALE
ES	ÓVALO

<input checked="" type="checkbox"/> #	115030
Formen/cups	9 x 50 ml
↔ mm	70 x 50
↑ mm	20



DE	BISKUIT
EN	SPONGE CAKE
IT	PAN DI SPAGNA
ES	BIZCOCHO

<input checked="" type="checkbox"/> #	115036
Formen/cups	3 x 140 ml
Ø mm	103
↑ mm	20



DE	RECHTECK MINI
EN	FINANCIERS MINI
IT	FINANZIERI MINI
ES	RECTÁNGULO MINI

<input checked="" type="checkbox"/> #	115037
Formen/cups	20 x 20 ml
↔ mm	49 x 26
↑ mm	11



DE	HERZ
EN	HEART
IT	CUORE
ES	CORAZÓN

<input checked="" type="checkbox"/> #	115039
Formen/cups	8 x 90 ml
Ø mm	60
↑ mm	35



DE	HERZ
EN	HEART
IT	CUORE
ES	CORAZÓN

<input checked="" type="checkbox"/> #	115069
Formen/cups	6 x 130 ml
Ø mm	65
↑ mm	40



DE	GUGELHUPF MEDIUM
EN	GUGELHUPF MEDIUM
IT	GUGELHUPF MEDIUM
ES	GUGELHUPF MEDIO

<input checked="" type="checkbox"/> #	115071
Formen/cups	6 x 80 ml
Ø mm	70
↑ mm	36



DE	GUGELHUPF MINI
EN	GUGELHUPF MINI
IT	GUGELHUPF MINI
ES	GUGELHUPF MINI

<input checked="" type="checkbox"/> #	115072
Formen/cups	8 x 50 ml
Ø mm	55
↑ mm	36



DE	HERZ "PASSION"
EN	HEART "PASSION"
IT	CUORE "PASSIONE"
ES	CORAZÓN "PASIÓN"

<input checked="" type="checkbox"/> #	115090
Formen/cups	24 x 16 ml
Ø mm	37 x 36
↑ mm	23



DE	HERZ "PASSION"
EN	HEART "PASSION"
IT	CUORE "PASSIONE"
ES	CORAZÓN "PASIÓN"

<input checked="" type="checkbox"/> #	115091
Formen/cups	10 x 45 ml
Ø mm	56 x 52
↑ mm	29



DE	HERZ "PASSION"
EN	HEART "PASSION"
IT	CUORE "PASSIONE"
ES	CORAZÓN "PASIÓN"

☑ #	115092
Formen/cups	8 x 72 ml
↔ mm	64 x 62
↑ mm	32



DE	ROSE
EN	ROSE
IT	ROSA
ES	ROSA

☑ #	115093
Formen/cups	15 x 23 ml
↔ mm	44
↑ mm	27



DE	ROSE
EN	ROSE
IT	ROSA
ES	ROSA

☑ #	115094
Formen/cups	6 x 115 ml
↔ mm	76
↑ mm	40



DE	KUBUS
EN	CUBE
IT	CUBO
ES	CUBO

☑ #	115098
Formen/cups	8 x 125 ml
↔ mm	50 x 50
↑ mm	50



DE	KUBUS
EN	CUBE
IT	CUBO
ES	CUBO

☑ #	115099
Formen/cups	15 x 42 ml
↔ mm	35 x 35
↑ mm	35



DE	MUFFIN GROSS
EN	MUFFIN BIG
IT	MUFFIN GRANDE
ES	MUFFIN GRANDE

☑ #	115131
Formen/cups	6 x 165 ml
Ø mm	75
↑ mm	60

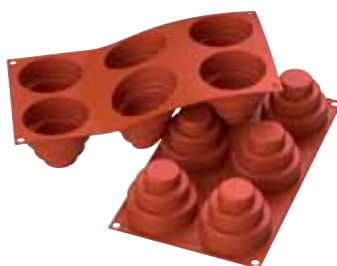

DE	MINI-KUCHEN
EN	MINI-WONDERCAKE
IT	MINITORTA
ES	PASTEL MINI

☑ #	115211
Formen/cups	6 x 177 ml
Ø mm	59 x 29
↑ mm	70

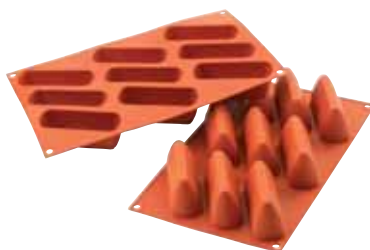

DE	NUSSPRALINE
EN	NUT TRUFFLE
IT	GIANDUIOTTO
ES	BOMBÓN LA NUEZ

☑ #	115212
Formen/cups	9 x 85 ml
↔ mm	93 x 31
↑ mm	42



DE	MULDE
EN	HOLLOW
IT	TRONQUETTO
ES	TRONCO MINI

☑ #	115213
Formen/cups	9 x 83 ml
↔ mm	84 x 32
↑ mm	35

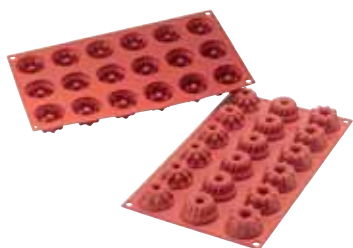

DE	MINI FANTASY
EN	MINI FANTASY
IT	MINI FANTASIA
ES	MINI FANTASY

<input checked="" type="checkbox"/> #	115215
Formen/cups	18 x 17,5 ml
↔ mm	40
↑ mm	22



DE	HALBKUGELN MINI
EN	HALF-SPHERES MINI
IT	SEMISFERE MINI
ES	SEMIESFERAS MINI

<input checked="" type="checkbox"/> #	115220
Formen/cups	24 x 10 ml
Ø mm	30
↑ mm	15



DE	MUFFIN MEDIUM
EN	MUFFIN MEDIUM
IT	MUFFIN MEDIUM
ES	MUFFIN MEDIUM

<input checked="" type="checkbox"/> #	115221
Formen/cups	6 x 119 ml
Ø mm	68
↑ mm	38



DE	FLAN MINI
EN	FLAN MINI
IT	FLAN MINI
ES	FLAN MINI

<input checked="" type="checkbox"/> #	115223
Formen/cups	15 x 30 ml
Ø mm	50
↑ mm	14



DE	FLAN
EN	FLAN
IT	FLAN
ES	FLAN

<input checked="" type="checkbox"/> #	115225
Formen/cups	6 x 72 ml
Ø mm	80
↑ mm	18



DE	FLORENTINER MINI
EN	FLORENTINES MINI
IT	FLORENTINE MINI
ES	FLORENTINAS MINI

<input checked="" type="checkbox"/> #	115226
Formen/cups	24 x 5 ml
Ø mm	35
↑ mm	5



DE	GUGELHUPF
EN	GUGELHUPF
IT	GUGELHUPF
ES	GUGELHUPF

<input checked="" type="checkbox"/> #	115227
Formen/cups	6 x 100 ml
Ø mm	75
↑ mm	40



DE	KUBUS MINI
EN	CUBE MINI
IT	CUBO MINI
ES	CUBO MINI

<input checked="" type="checkbox"/> #	115228
Formen/cups	40 x 13,5 ml
→ mm	24
↑ mm	24



DE	ZYLINDER MINI
EN	CYLINDER MINI
IT	CILINDRO MINI
ES	CILINDROS MINI

<input checked="" type="checkbox"/> #	115229
Formen/cups	11 x 55 ml
Ø mm	50
↑ mm	27

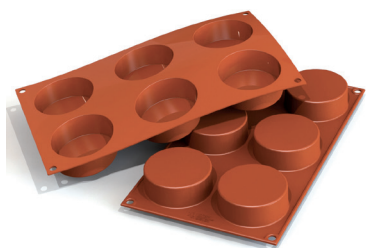

DE	ZYLINDER
EN	CYLINDER
IT	CILINDRO
ES	CILINDROS

<input checked="" type="checkbox"/> #	115230
Formen/cups	6 x 103,5 ml
Ø mm	70
↑ mm	27

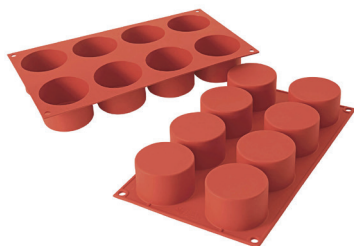

DE	ZYLINDER MEDIUM
EN	CYLINDER MEDIUM
IT	CILINDRO MEDIUM
ES	CILINDROS MEDIUM

<input checked="" type="checkbox"/> #	115231
Formen/cups	8 x 123 ml
Ø mm	63
↑ mm	40

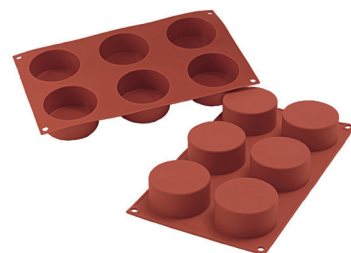

DE	ZYLINDER
EN	CYLINDER
IT	CILINDRO
ES	CILINDROS

<input checked="" type="checkbox"/> #	115232
Formen/cups	6 x 133 ml
Ø mm	70
↑ mm	35



DE	RECHTECK
EN	FINANCIERS
IT	FINANZIERI
ES	RECTÁNGULO

<input checked="" type="checkbox"/> #	115233
Formen/cups	6 x 110 ml
↔ mm	120 x 45
↑ mm	20

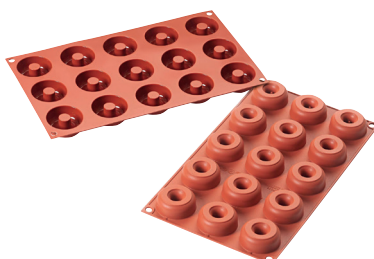

DE	DONUTS MINI
EN	DONUTS MINI
IT	DONUTS MINI
ES	DONUTS MINI

<input checked="" type="checkbox"/> #	115234
Formen/cups	15 x 22 ml
Ø mm	45
↑ mm	18

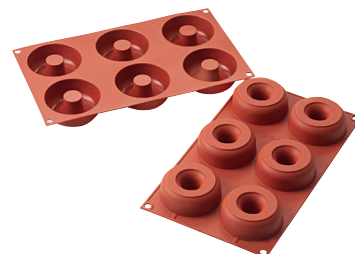

DE	DONUTS
EN	DONUTS
IT	DONUTS
ES	DONUTS

<input checked="" type="checkbox"/> #	115235
Formen/cups	6 x 98 ml
Ø mm	75
↑ mm	25



DE	QUENELLE
EN	QUENELLE
IT	QUENELLE
ES	QUENELLA

<input checked="" type="checkbox"/> #	115254
Formen/cups	12 x 24 ml
Ø mm	63 x 29
↑ mm	28



**BACKFORMEN AUS SILIKON 600 x 400 mm**

Material: hochwertiges und lebensmittelechtes Silikon, mit Antihafteffekt – kein vorheriges Einfetten mehr notwendig!  
 Temperaturbereich: – 60 bis + 230 °C (für Backöfen, Mikrowelle oder Gefrierschränke)  
 Größe der Backformen: 400 x 600 mm

Bei richtiger Anwendung sind folgende Punkte zu beachten:

- Backgut immer abkühlen lassen
- Backformen niemals in direkten Kontakt mit Herdplatten, Feuer oder Grill bringen (am besten die Backformen auf Gitter oder Backbleche auflegen)
- Niemals das Backgut mit scharfen Gegenständen heraustrennen
- Niemals aggressive Reinigungsmittel verwenden, sondern von Hand reinigen

**BAKING MOULDS MADE OF SILICONE 600 x 400 mm**

Made of high quality, food safe and non-sticking silicone – without prior greasing!  
 Temperature range: from – 60 to + 230 °C (for ovens, microwaves and freezers)  
 Size of the baking moulds: 400 x 600 mm

For optimal using please note the following points:

- Let cool down the products before extraction
- Never use baking moulds on heat sources (fire, grill, electric plates)
- Never use sharp objects to remove your products from the moulds
- Never use aggressive detergents to clean moulds after use, just clean by hand

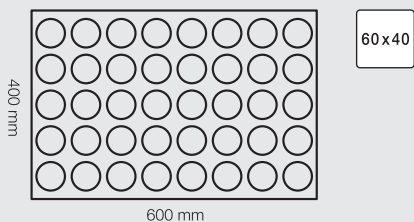



DE	BRIOCHE
EN	BRIOCHE
IT	BRIOCHE
ES	BRIOCHETTE

<input checked="" type="checkbox"/> #	115300
Formen/cups	24 x 84 ml
Ø mm	79
↑ mm	35



DE	HALBKUGEL
EN	HALF-SPHERE
IT	SEMISFERA
ES	SEMIESFERA

<input checked="" type="checkbox"/> #	115302
Formen/cups	28 x 90 ml
Ø mm	70
↑ mm	35



DE	FLORENTINER
EN	FLORENTINES
IT	FIORENTINE
ES	FLORENTINAS

<input checked="" type="checkbox"/> #	115303
Formen/cups	40 x 25 ml
Ø mm	60
↑ mm	11



DE	MADELEINE
EN	MADELEINE
IT	MADELEINE
ES	MADELEINE

<input checked="" type="checkbox"/> #	115304
Formen/cups	44 x 32 ml
Ø mm	77 x 44,5
↑ mm	18



DE	RECHTECK
EN	FINANCIERS
IT	FINANZIERI
ES	RECTÁNGULO

<input checked="" type="checkbox"/> #	115307
Formen/cups	30 x 130 ml
Ø mm	99 x 49
↑ mm	30



DE	MUFFIN
EN	MUFFIN
IT	MUFFIN
ES	MUFFIN

<input checked="" type="checkbox"/> #	115308
Formen/cups	24 x 122 ml
Ø mm	69
↑ mm	39



DE	MUFFIN-MINI
EN	MUFFIN MINI
IT	MUFFIN MINI
ES	MUFFIN MINI

<input checked="" type="checkbox"/> #	115309
Formen/cups	70 x 40 ml
Ø mm	45
↑ mm	30



DE	GUGELHUPF
EN	GUGELHUPF
IT	GUGELHUPF
ES	GUGELHUPF

<input checked="" type="checkbox"/> #	115310
Formen/cups	35 x 90 ml
Ø mm	72
↑ mm	35



DE	CREME-FORM
EN	YULE LOG
IT	TRONCHETTO
ES	TRONCO

<input checked="" type="checkbox"/> #	115311
Formen/cups	4 x 2137 ml
Ø mm	495 x 80
↑ mm	63



DE BISKUIT  
EN SPONGE CAKE  
IT PAN DI SPAGNA  
ES BIZCOCHOS

<input checked="" type="checkbox"/> #	115312
Formen/cups	6 x 200 ml
Ø mm	160
↑ mm	10



DE BISKUIT  
EN SPONGE CAKE  
IT PAN DI SPAGNA  
ES BIZCOCHOS

<input checked="" type="checkbox"/> #	115313
Formen/cups	12 x 112 ml
Ø mm	120
↑ mm	10



DE RINNE  
EN FLUTING  
IT TRONCHETTO  
ES TRONCO RECTANGULAR

<input checked="" type="checkbox"/> #	115315
Formen/cups	4 x 2401 ml
↔ mm	495 x 70
↑ mm	70



DE WAFFLE  
EN WAFFLE  
IT CIALDA  
ES WAFFLE

<input checked="" type="checkbox"/> #	115336
Formen/cups	20 x 113 ml
Ø mm	95 x 70
↑ mm	24

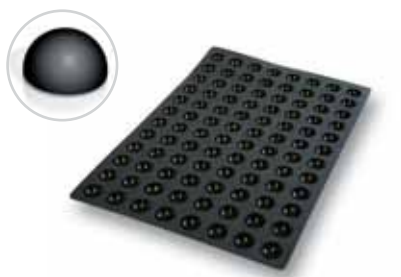

DE HALBKUGELN MINI  
EN HALF-SPHERES MINI  
IT SEMISFERE MINI  
ES SEMIESFERAS MINI

<input checked="" type="checkbox"/> #	115338
Formen/cups	96 x 11 ml
Ø mm	35
↑ mm	17,5



DE BISKUIT  
EN SPONGE CAKE  
IT PAN DI SPAGNA  
ES BIZCOCHOS

<input checked="" type="checkbox"/> #	115340
Formen/cups	12 x 120 ml
Ø mm	120
↑ mm	22

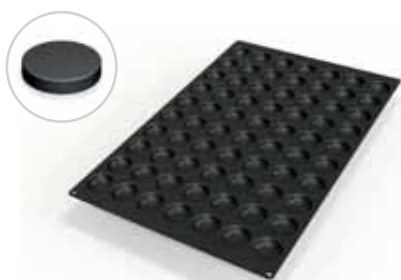

DE FLORENTINER MINI  
EN FLORENTINES MINI  
IT FIORENTINE MINI  
ES FLORENTINAS MINI

<input checked="" type="checkbox"/> #	115341
Formen/cups	70 x 15 ml
Ø mm	45
↑ mm	10

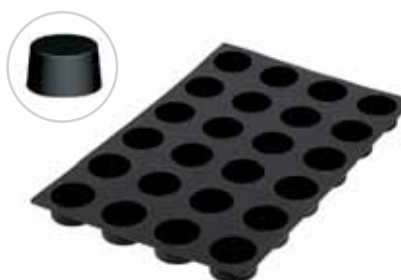

DE ZYLINDER  
EN CYLINDER  
IT CILINDRO  
ES CILINDROS

<input checked="" type="checkbox"/> #	115343
Formen/cups	24 x 133 ml
Ø mm	70
↑ mm	35



DE BISKUIT  
EN SPONGE CAKE  
IT PAN DI SPAGNA  
ES BIZCOCHOS

<input checked="" type="checkbox"/> #	115344
Formen/cups	8 x 382 ml
Ø mm	140
↑ mm	25



DE	BISKUIT
EN	SPONGE CAKE
IT	PAN DI SPAGNA
ES	BIZCOCHOS

<input checked="" type="checkbox"/> #	115345
Formen/cups	15 x 341 ml
Ø mm	105
↑ mm	40



DE	GUGELHUPF
EN	GUGELHUPF
IT	GUGELHUPF
ES	GUGELHUPF

<input checked="" type="checkbox"/> #	115347
Formen/cups	35 x 80 ml
Ø mm	60
↑ mm	30



DE	WAFFEL
EN	WAFFLE
IT	CIALDA
ES	WAFFLE

<input checked="" type="checkbox"/> #	115349
Formen/cups	18 x 107 ml
Ø mm	90
↑ mm	24



DE	DONUTS
EN	DONUTS
IT	DONUTS
ES	DONUTS

<input checked="" type="checkbox"/> #	115350
Formen/cups	24 x 133 ml
Ø mm	85
↑ mm	29





**EINZELNE TORTENFORMEN AUS SILIKON**

Material: hochwertiges und lebensmittelechtes Silikon, mit Antihafteffekt – kein vorheriges Einfetten mehr notwendig!

Temperaturbereich: –60 bis +230 °C (für Backöfen, Mikrowelle oder Gefrierschränke)

Bei richtiger Anwendung sind folgende Punkte zu beachten:

- Backgut immer abkühlen lassen.
- Backformen niemals in direkten Kontakt mit Herdplatten, Feuer oder Grill bringen (am besten die Backformen auf Gitter oder Backbleche auflegen)
- Niemals das Backgut mit scharfen Gegenständen heraustrennen
- Niemals aggressive Reinigungsmittel verwenden, sondern von Hand reinigen

**SINGLE CAKE MOULDS MADE OF SILICONE**

Made of high quality and non-sticking silicone – without prior greasing!

Temperature range: from –60 to +230 °C (for ovens, microwaves and freezers)

For optimal using please note the following points:

- Let cool down the products before extraction
- Never use baking moulds on heat sources (fire, grill, electric plates)
- Never use sharp objects to remove your products from the moulds
- Never use aggressive detergents to clean moulds after use, just clean by hand





DE	GLATT
EN	PLAIN
IT	LISCIO
ES	REDONDO, LISO

<input checked="" type="checkbox"/> #	115043	115044
↔ mm	260	280
↑ mm	45	45



DE	GEZACKT
EN	SERRATED
IT	FESTONATA
ES	REDONDO, RIZADO

<input checked="" type="checkbox"/> #	115046
↔ mm	280
↑ mm	30



DE	KÖNIGSKUCHEN
EN	PLUM CAKE
IT	PLUMCAKE
ES	PLUMCAKE

<input checked="" type="checkbox"/> #	115050
↔ mm	240 x 105
↑ mm	65



DE	KÖNIGSKUCHEN
EN	PLUM CAKE
IT	PLUMCAKE
ES	PLUMCAKE

<input checked="" type="checkbox"/> #	115095
↔ mm	260 x 100
↑ mm	70



DE	KÖNIGSKUCHEN
EN	PLUM CAKE
IT	PLUMCAKE
ES	PLUMCAKE

<input checked="" type="checkbox"/> #	115096
↔ mm	300 x 100
↑ mm	70



DE	GUGELHUPF
EN	GUGELHUPF
IT	GUGELHUPF
ES	GUGELHUPF

<input checked="" type="checkbox"/> #	115097
↔ mm	220
↑ mm	110

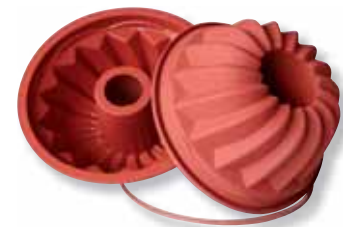

DE	GUGELHUPF
EN	GUGELHUPF
IT	GUGELHUPF
ES	GUGELHUPF

<input checked="" type="checkbox"/> #	115184
↔ mm	200
↑ mm	90

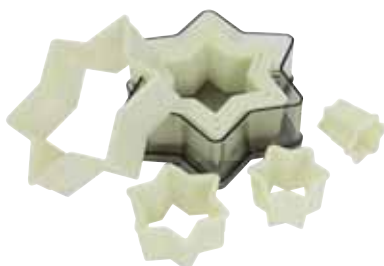
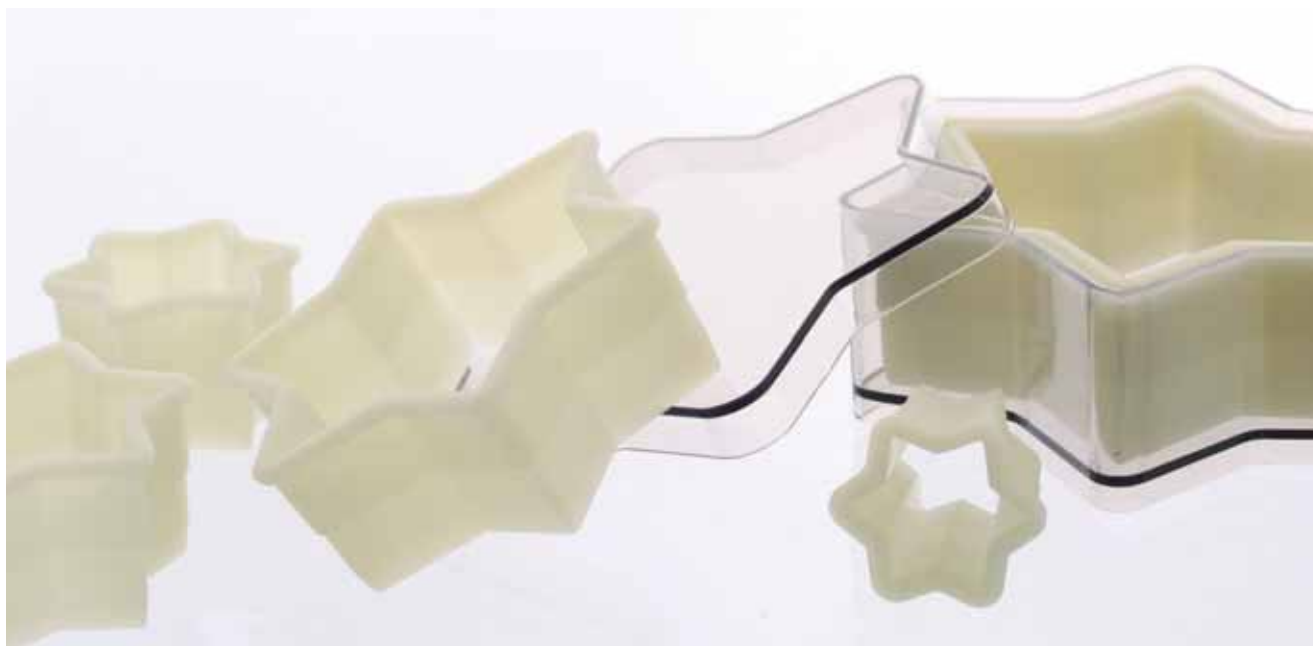

# 166110

DE	AUSSTECHEK SÄTZE	
EN	SETS OF PASTRY CUTTERS	
IT	SET DI TAGLIAPASTA	
ES	JUEGOS DE CORTAPASTAS	

Material: Nylon  
 • Höhe: 35 mm

Made of nylon  
 • Height: 35 mm

#		Ø mm / ↔ mm	
166100	9-teilig, RUND, glatt / 9 pieces, ROUND, plain	20, 30, 40, 50, 60, 70, 80, 90, 100	
166101	9-teilig, RUND, gezackt / 9 pieces, ROUND, serrated	20, 30, 40, 50, 60, 70, 80, 90, 100	
166102	9-teilig, QUADRAT, glatt / 9 pieces, SQUARE, plain	19 / 28 / 37 / 47 / 57 / 67 / 76 / 86 / 95	
166103	9-teilig, QUADRAT, gezackt / 9 pieces, SQUARE, serrated	19 / 28 / 37 / 47 / 57 / 67 / 76 / 86 / 95	
166104	7-teilig, HERZ, glatt / 7 pieces, HEART, plain	120 x 115 / 105 x 100 / 90 x 85 / 75 x 70 / 65 x 55 / 45 x 40 / 30 x 25	
166105	7-teilig, HERZ, gezackt / 7 pieces, HEART, serrated	120 x 115 / 105 x 100 / 90 x 85 / 75 x 70 / 65 x 55 / 45 x 40 / 30 x 25	
166106	7-teilig, HALBMOND, glatt / 7 pieces, HALF MOON, plain	69 x 20 / 80 x 28 / 90 x 35 / 98 x 43 / 100 x 50 / 110 x 58 / 114 x 65	
166107	7-teilig HALBMOND, gezackt / 7 pieces, HALF MOON, serrated	69 x 20 / 80 x 28 / 90 x 35 / 98 x 43 / 100 x 50 / 110 x 58 / 114 x 65	
166108	7-teilig, OVAL, glatt / 7 pieces, OVAL, plain	21 x 10 / 35 x 20 / 50 x 30 / 65 x 35 / 80 x 45 / 95 x 55 / 110 x 65	
166109	7-teilig, OVAL, gezackt / 7 pieces, OVAL, serrated	21 x 10 / 35 x 20 / 50 x 30 / 65 x 35 / 80 x 45 / 95 x 55 / 110 x 65	
166110	7-teilig, STERN, glatt / 7 pieces, STAR, plain	130 x 115 / 115 x 100 / 100 x 85 / 85 x 70 / 70 x 60 / 55 x 45 / 40 x 35	
166120	26-teilig „BUCHSTABEN“ / 26 pieces “LETTERS”	15 / 45 x 40	
166121	15-teilig „ZAHLEN“ / 15 pieces “NUMBERS”	15 / 60 x 45	



# 166100



# 166101

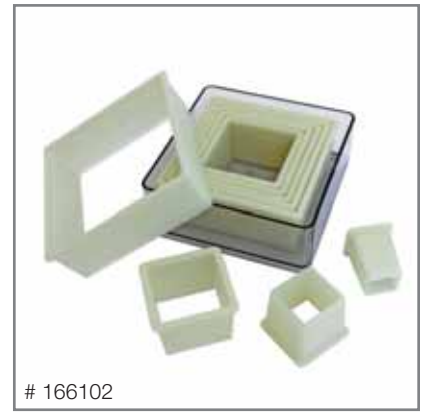

# 166102



# 166103



# 166104



# 166105



# 166106



# 166107



# 166108



# 166109



# 166120



# 166121



DE	AUSSTECHEKERSÄTZE	SST
EN	SETS OF PASTRY CUTTERS	
IT	SET DI TAGLIAPASTA	
ES	JUEGOS DE CORTAPASTAS	

- Materialstärke: 0,4 – 0,5 mm
- Höhe: 30 mm
- Thickness: 0.4 – 0.5 mm
- Height: 30 mm

#		Ø mm / ↔ mm	
199500	9-teilig, RUND, glatt / 9 pieces, ROUND, plain	30, 40, 50, 60, 70, 80, 90, 100, 110	
199501	16-teilig, RUND, glatt / 16 pieces, ROUND, plain	20, 30, 40, 50, 60, 70, 75, 80, 85, 90, 95, 100, 110, 120, 125, 140	
199502	9-teilig, RUND, gezackt / 9 pieces, ROUND, serrated	30, 40, 50, 60, 70, 80, 90, 100, 110	
199503	12-teilig, RUND, gezackt / 12 pieces, Round, serrated	30, 40, 50, 60, 70, 80, 90, 100, 110, 120, 130, 140	
199504	9-teilig, OVAL, glatt / 9 pieces, OVAL, plain	27/34, 35/46, 46/57, 55/66, 65/76, 74/86, 85/94, 95/107, 105/116	
199505	12-teilig, OVAL, glatt / 12 pieces, OVAL, plain	27/34, 33/46, 42/57, 54/68, 65/78, 74/87, 85/97, 92/107, 105/117, 113/127, 121/136, 131/146	
199506	9-teilig, OVAL, gezackt / 9 pieces, OVAL, serrated	27/45, 34/55, 44/57, 53/75, 63/85, 72/94, 84/106, 94/113, 102/117	
199507	12-teilig, OVAL, gezackt / 12 pieces, OVAL, serrated	26/35, 33/46, 45/54, 55/64, 66/74, 71/87, 84/95, 99/105, 102/114, 113/127, 121/136, 131/143	
199508	9-teilig, STERN, glatt / 9 pieces, STAR, plain	37, 51, 64, 82, 95, 110, 122, 134, 149	
199510	9-teilig, HERZ, glatt / 9 pieces, HEART, plain	35, 42, 51, 58, 68, 80, 90, 100, 110	
199511	9-teilig, HERZ, gezackt / 9 pieces, HEART, serrated	58, 68, 80, 90, 102, 110, 123, 130, 140	



5



DE	AUSSTECHERSÄTZE	<b>SST</b>
EN	SETS OF PASTRY CUTTERS	
IT	SET DI TAGLIAPASTA	
ES	JUEGOS DE CORTAPASTAS	

- Materialstärke: 0,4 mm
- Höhe: 50 mm
- Thickness: 0.4 mm
- Height: 50 mm

#		Ø mm
199513	<b>12-teilig</b> , rund, gezackt / 12 pieces, round, serrated	30, 35, 43, 48, 55, 62, 70, 75, 82, 91, 97, 103

- Materialstärke: 0,4 – 0,5 mm
- Höhe: 30 mm
- Thickness: 0.4 – 0.5 mm
- Height: 30 mm



# 199520

#		Ø mm / ↔ mm
199641	<b>9-teilig</b> , Quadrat, glatt / 9 pieces, Square, plain	25/25, 32/32, 38/38, 45/45, 50/50, 58/58, 67/67, 74/74, 82/82
199642	<b>9-teilig</b> , Blüte, glatt / 9 pieces, Blossom, plain	40, 54, 67, 80, 93, 105, 118, 133, 149
199643	<b>9-teilig</b> , Dreieck, glatt / 9 pieces, Triangle, plain	Seite / side: 42, 53, 61, 71, 80, 90, 103, 110, 124
199520	<b>9-teilig, doppel</b> , rund, glatt und gezackt / <b>9 pieces, double</b> round, plain and serrated	30, 40, 50, 60, 70, 80, 90, 98, 110



DE	DEKOR-AUSSTECHERSÄTZE "GEMISCHTE FORMEN"	<b>SST</b>
EN	SETS OF DECORATING CUTTERS "MIXED"	
IT	SET DI TAGLIAPASTA "MISTI"	
ES	JUEGOS DE CORTAPASTAS "FIGURAS VARIADAS"	

- Materialstärke: 0,3 mm
- Dosendurchmesser: 100 mm
- Thickness: 0.3 mm
- Tin diameter 100 mm

#		↑ mm
199656	12 Stück / 12 pieces	20
199657	10 Stück / 10 pieces	20
199658	10 Stück / 10 pieces	20



DE	DONUT-AUSSTECHER	<b>SST</b>
EN	DOUGHNUT CUTTERS	
IT	TAGLIAPASTA PER CIAMBELLE	
ES	CORTADONUTS	

#	Ø mm	Ø mm	↓ mm
155009	60	25	20
155010	67	30	17
155011	80	40	20



DE	PETIT-FOURS-AUSSTECHERSATZ	<b>SST</b>
EN	SET OF PETIT-FOUR-CUTTERS	
IT	SET DI TAGLIAPASTA (9 PZ.) "PETIT FOURS"	
ES	JUEGO DE CORTAPASTAS (9 U.) PARA PETIT FOURS	

- 9-teilig
- 9 pieces

#	
199530	Arche, Kurve, Diamant, Herz, Oval Oval rund, Rund, Rechteck, Quadrat / arch, curve, diamond, heart, oval oval round, round, rectangle, square

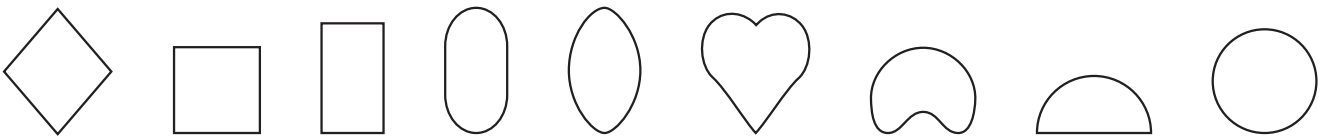

DE	ZIMTSTERN-AUSSTECHER	<b>SST</b>
EN	CINNAMON STAR CUTTER	
IT	TAGLIAPASTA "STELLA"	
ES	CORTAPASTAS "ESTRELLA"	

- Stabiler Griff
- Federmechanismus
- Solid handle
- Spring mechanism

#	↔ mm	↑ mm
199584	50	97





DE	DEKOR-AUSSTECHECHERSÄTZE	SST
EN	SETS OF DECORATING CUTTERS	
IT	SET DI TAGLIAPASTA	
ES	JUEGOS DE CORTAPASTAS	

• Materialstärke: 0,3 mm

• Thickness: 0.3 mm

#		Ø mm	↑ mm	
199650	“GEOMETRIE” 18 Stück / “GEOMETRY” 18 pieces	150	20	
199651	“BLUMEN” 20 Stück / “FLOWERS” 20 pieces	150	20	
199652	“GEMISCHTE FORMEN” 20 Stück / “MIXED” 20 pieces	150	20	
199653	“GEMISCHTE FORMEN” 15 Stück / “MIXED” 15 pieces	130	20	
199654	“GEMISCHTE FORMEN” 14 Stück / “MIXED” 14 pieces	130	20	
199655	“GEMISCHTE FORMEN” 15 Stück / “MIXED” 15 pieces	130	20	
199659	“ZAHLEN” 16 Stück / “NUMBERS” 16 pieces	100	20	
199660	BUCHSTABEN- UND ZAHLENAUSSTECHECHER 40 Stück / ALPHABETH AND NUMBER CUTTERS 40 pieces	150	20	
199661	BUCHSTABENAUSSTECHECHER 26 Stück / ALPHABETH CUTTERS 26 pieces	120	20	
199662	“GEOMETRIE” 24 Stück / “GEOMETRY” 24 pieces Jede Form in 3 ver. Größen / each design in three different sizes	120	20	
199663	“HERZ” 24 Stück / “HEART” 24 pieces Jede Form in 3 ver. Größen / each design in three different sizes	120	20	



# 199650



# 199651



# 199652



# 199653



# 199654



# 199655



# 199659



# 199660



# 199661



# 199662

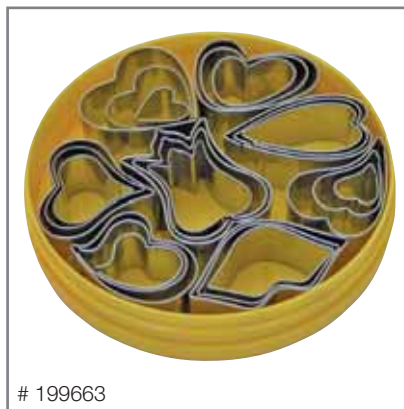

# 199663

5



DE	DEKOR-AUSSTECHECHERSÄTZE	<b>SST</b>
EN	SETS OF DECORATING CUTTERS	
IT	SET DI TAGLIAPASTA	
ES	SET DE CORTAPASTAS	

• Materialstärke: 0,3 mm

• Thickness: 0.3 mm

#		Ø mm	↑ mm	
199173	“BLUMEN” 8 Stück, mit Griff / “FLOWERS” 8 pieces, with handle	100	20	
199174	“GEOMETRIE” 8 Stück, mit Griff / “GEOMETRY” 8 pieces, with handle	100	20	
199175	“KARTENSPIEL” 8 Stück, mit Griff / “CARDS” 8 pieces, with handle	100	20	
199176	“GEOMETRIE” 15 Stück / “GEOMETRY” 15 pieces	160	20	
199177	“TIERE” 12 Stück / “ANIMALS” 12 pieces	160	20	
199178	“NIKOLAUS” 3 Stück / “SANTA CLAUS” 3 pieces	100	20	
199179	“TANNEN” 3 Stück / “CHRISTMAS TREES” 3 pieces	100	20	
199180	“KREUZE” 5 Stück / “CROSSES” 5 pieces	100	20	
199181	“GLOCKEN” 5 Stück / “JINGLE BELLS” 5 pieces	100	20	
199182	“SCHNEEFLOCKE” 5 Stück / “SNOWFLAKE” 5 pieces	100	20	
199183	“GEMISCHTE FORMEN” 15 Stück / “MIXED” 15 pieces	100	20	
199184	“BLUMEN” 15 Stück / “FLOWERS” 15 pieces	100	20	



5

DE	AUSSTECHEMATTEN
EN	CUTTING SHEETS
IT	PLACCHE PASTAFROLLA TAGLIABISCOTTI
ES	PLACAS CORTAPASTAS

Aus hochschlagfestem Kunststoff

- Lebensmittelneutral
- Geruchlos
- Scharfkantig
- Leicht zu säubern
- Aussenabmessungen: 580 x 390 mm

Made of white, impact-resistant plastic

- Odourless
- Warranted free of substances
- Sharp-edged
- Easy to clean
- Outer dimensions: 580 x 390 mm

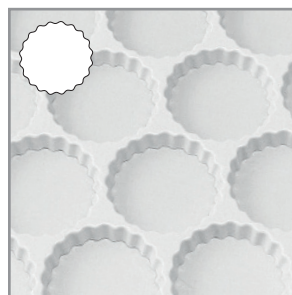

# 166001

1

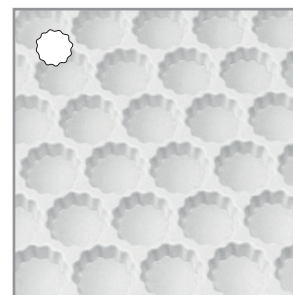

# 166002

2

#	Nr. / no.	Ø mm		Nutz. / pcs.	
166001	1	90	rund gezackt / round, serrated	20	
166002	2	45	rund gezackt / round, serrated	72	
166022	2a	35	rund gezackt / round, serrated	90	
166003	3	53	rund, glatt / round, plain	53	
166023	3a	35	rund, glatt / round, plain	95	
166004	4	45	Stern / star	63	
166024	4a	35	Stern / star	95	
166005	5	50	Kleeblatt / four-leaf clover	63	
166025	5a	35	Kleeblatt / four-leaf clover	105	
166006	6	45	Herz / heart	95	
166026	6a	35	Herz / heart	116	
166007	7	48	Halbmond / half moon	78	
166027	7a	35	Halbmond / half moon	128	
166008	8	48	Dreiblatt / clover	68	
166028	8a	35	Dreiblatt / clover	105	
166009	9	80 / 66	Tanne, Komet / fir tree, comet	50	
166010	10	60	Tropfen „Munzenmandeln“ / drop	36	
166030	10a	51	Tropfen „Munzenmandeln“ / drop	72	
166032	12	60	Glocke / bell	55	
166029	13	92	Küken, Hase / chick, rabbit	64	
166034	15	63 / 65	Apfel, Birne / appel, pear	25 / 20	
166037	18	70 / 75	Seehund, Pinguin / seal, penguin	25 / 16	

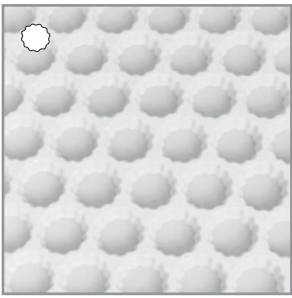

# 166022 2a

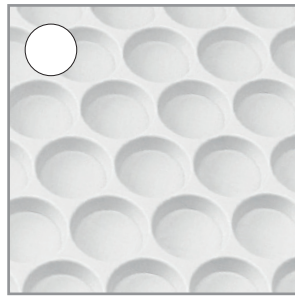

# 166003 3

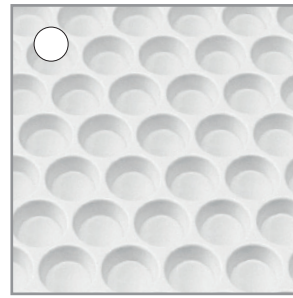

# 166023 3a



# 166004 4

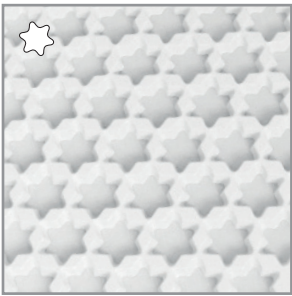

# 166024 4a

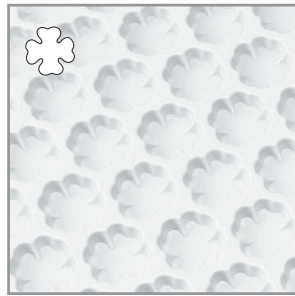

# 166005 5

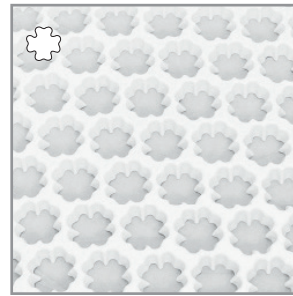

# 166025 5a



# 166006 6

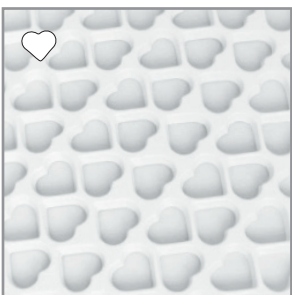

# 166026 6a

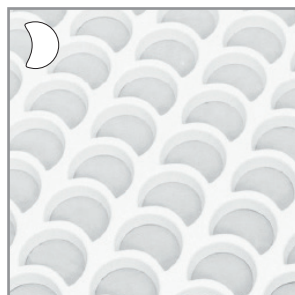

# 166007 7

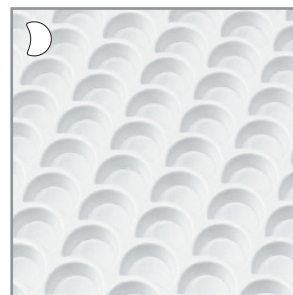

# 166027 7a



# 166008 8

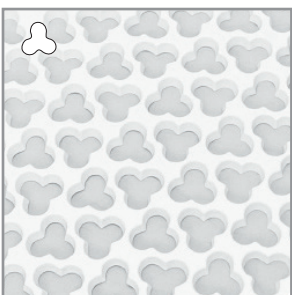

# 166028 8a



# 166009 9

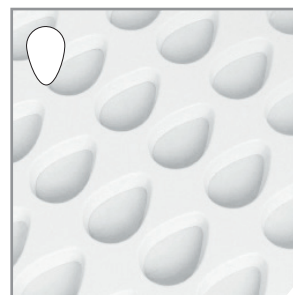

# 166010 10



# 166030 10a

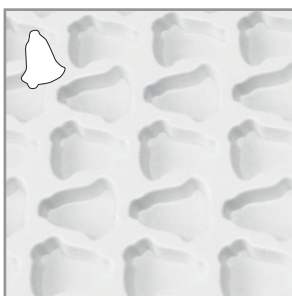

# 166032 12

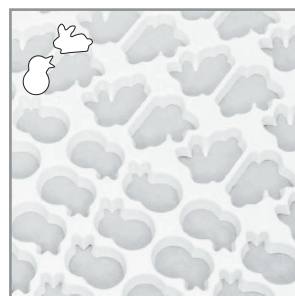

# 166029 13



# 166034 15

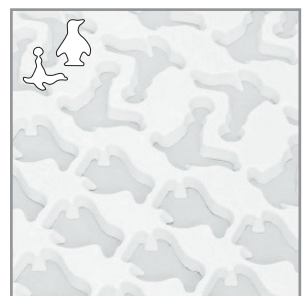

# 166037 18



© Erich Muecke - stock.adobe.com

DE	AUSSTECHER	<b>SST</b>
EN	CUTTERS	
IT	TAGLIAPASTA	
ES	CORTAPASTAS	

#		Ø mm / ↔ mm	↑ mm	
199700	rund, glatt / round, plain	Ø 120	30	
199710	rund, glatt / round, plain	Ø 140	30	
199720	rund, gezackt / round, serrated	Ø 120	30	
199730	rund, gezackt / round, serrated	Ø 140	30	
199740	rund, gezackt / round, serrated	Ø 145	30	
199750	quadrat, gezackt / square, serrated	85 x 85	45	
199887	“HERZ” / “HEART”	Ø 90	20	
199888	“BLÜTE” / “BLOSSOM”	Ø 91	20	
199890	“EI” / “EGG”	155 x 100	30	
199891	“EI” / “EGG”	190 x 125	30	
199150	“BANANE” / “BANANA	160	30	

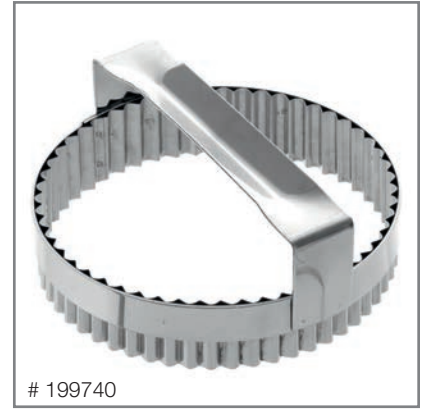



DE	AUSSTECHER	SST
EN	CUTTERS	
IT	TAGLIAPASTA	
ES	CORTAPASTAS	

#		Ø mm / ↔ mm	↑ mm	
199770	"FISCH" / "FISH"	145 x 65	35	
199886	"IGEL", 3 Größen / "HEDGEHOG", 3 sizes	67 / 75 / 90	30	
199163	"SONNENBLUME" / "SUNFLOWER"	Ø: 100	25	
199164	"SCHMETTERLING" / "BUTTERFLY"	Ø: 110	25	
199165	"WEIHNACHTSAUSSTECHER"; glatt mit Böden in 10 versch. Formen (0,3 mm) / "CHRISTMAS-CUTTERS"; plain, with strong base, 10 different types (0.3 mm)	Ø: 50		
199166	"WEIHNACHTSAUSSTECHER"; gewellt mit Böden in 10 versch. Formen (0,3 mm) / "CHRISTMAS-CUTTERS"; waded edges, with strong base, 10 different types (0.3 mm)	Ø: 50		
199167	"WEIHNACHTSAUSSTECHER"; glatt, 8-teilig, bestehend aus: Glocke, Tannenbaum, Schmetterling, Stern, Weihnachtsstern, Ente, Herz und Pilz (0,3 mm) / "CHRISTMAS-CUTTERS"; plain, 8 different types, consisting of: bell, christmas tree, butterfly, star, shooting star, duck, heart and mushroom (0.3 mm)			
199168	"NIKOLAUS", Materialstärke 0,5 mm / "SANTA CLAUS", thickness 0.5 mm	230 x 125	30	
199760	"KOMET" / "COMET"	230 x 110	30	
199761	"KOMET", Set: 3-teilig / "COMET", set: 3 pieces	87 x 35 127 x 50 167 x 75	20 20 20	
199169	"STERN MIT LOCH"; Materialstärke 0,4 mm / "STAR WITH HOLE"; thickness 0.4 mm	Ø: 105	30	
199170	"STUTENKERL"; Materialstärke 0,5 mm, zweiteilig / "GINGERBREAD MAN"; thickness 0.5 mm, two parts	250 x 220	30	

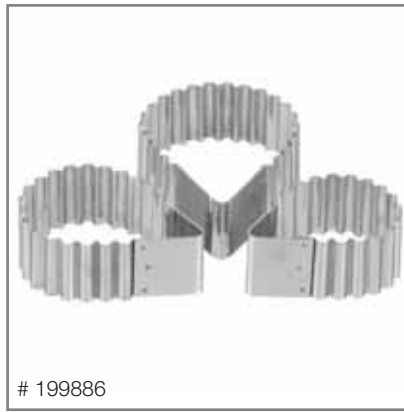

5



DE	AUSSTECHER	SST
EN	CUTTERS	
IT	TAGLIAPASTA	
ES	CORTAPASTAS	

#		↔ mm	↑ mm	
199780	“SCHNEEMANN” / “SNOW MAN”	145 x 80	30	
199790	“NIKOLAUSTIEFEL” / “CHRISTMAS BOOT”	140 x 110	30	
199800	“ENGEL” / “ANGEL”	140 x 100	30	
199171	“TANNENBAUM” / “CHRISTMAS TREE”	150 x 125	30	
199172	“TANNENBAUM” / “CHRISTMAS TREE”	200 x 153	30	
199820	“GLOCKE” / “JINGLE BELL”	130 x 110	30	
199860	“HASE” / “RABBIT”	180 x 80	30	
199870	“HASE” / “RABBIT”	200 x 170	30	
199850	“HASENKOPF” / “RABBIT HEAD”	170 x 125	30	
199830	“MARTINGANS” / “GOOSE”	170 x 215	30	
199840	“ENTE” / “DUCK”	200 x 170	30	

DE	AUSSTECHER
EN	CUTTERS
IT	TAGLIAPASTA
ES	CORTAPASTAS

Material: Weißblech

Made of tin

#		
199570	ZAHLENAUSSTECHER, Set mit 9 Zahlen (von 0 – 9) / NUMBER CUTTERS, set with 9 numbers (from 0 to 9)	
199571	WEIHNACHTSAUSSTECHER, Set mit 10 verschiedenen Ausstechern / CHRISTMAS CUTTERS, set with 10 different cutters	



# 199780



# 199790

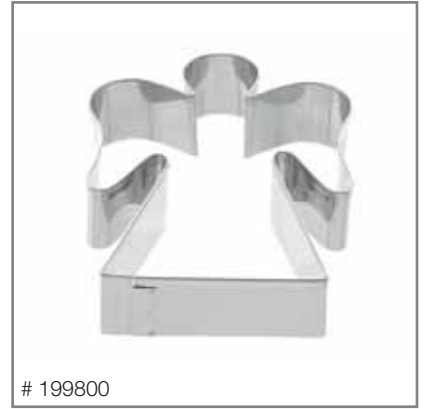

# 199800

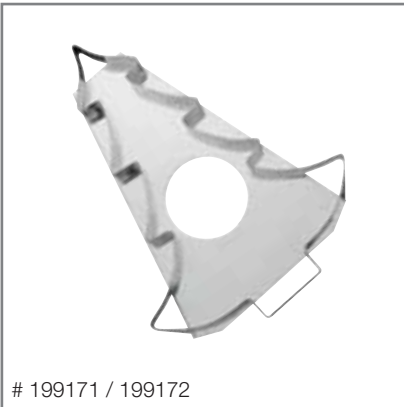

# 199171 / 199172



# 199820



# 199860



# 199870



# 199850



# 199830



# 199840



# 199570



# 199571

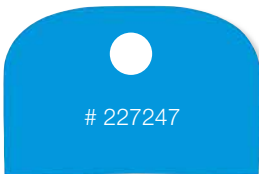
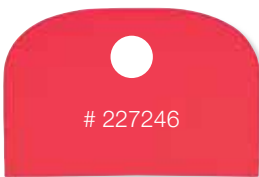
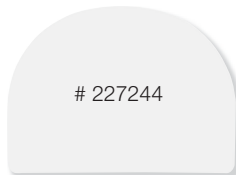
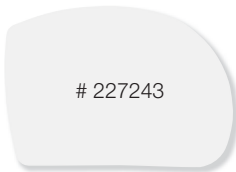
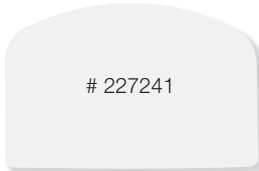
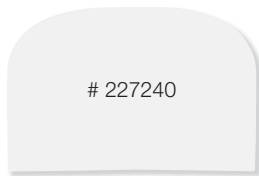

📌 Idealer Werbeträger (Prägung): eigenes Logo möglich /  
Ideal advertising media (embossment): own logo possible



DE	TEIGSCHABER	LDPE	SOFT	-35 +100 °C		
EN	DOUGH SCRAPER					
IT	RASCHIETTO DA IMPASTO					
ES	RASPADOR DE MASA					

- Ausführung: flexibel
- Type: flexible

#		↗ mm	→ mm	↑ mm	
227240	○	148	99	2	
227857	●	148	99	2	
227757	●	148	99	2	
227241	○	137	86	2	
227242	○	160	120	2	
227243	○	120	86	2	
227244	○	120	88	2	

DE	TEIGSCHABER SCHLESINGER	LDPE	SOFT	-35 +100 °C		
EN	DOUGH SCRAPER SCHLESINGER					
IT	RASCHIETTO DA IMPASTO SCHLESINGER					
ES	RASPADOR DE MASA SCHLESINGER					

- Ausführung: flexibel
- Type: flexible

#		↗ mm	→ mm	↑ mm	
227246	●	148	99	2	
227247	●	148	99	2	

DE	TEIGSCHABER	ABS	-30 +80 °C		
EN	DOUGH SCRAPER				
IT	RASCHIETTO DA IMPASTO				
ES	RASPADOR DE MASA				

#		↗ mm	→ mm	↑ mm	
227235	○	105	95	1	



6

DE	TEIGSCHABER	
EN	DOUGH SCRAPER	
IT	RASCHIETTO DA IMPASTO	
ES	RASPADOR DE MASA	

- Mit Griffleiste
- With reinforced grip

#		↗ mm	→ mm	↑ mm	
227350	○	221	130	5	
227850	●	221	130	5	
227750	●	221	130	5	
227351	○	209	130	5	
227364	○	125	100	5	



DE	TEIGSCHABER	
EN	DOUGH SCRAPER	
IT	RASCHIETTO DA IMPASTO	
ES	RASPADOR DE MASA	

- Mit Griffleiste
- With reinforced grip

#		↗ mm	→ mm	↑ mm	
227230	○	120	100	5	

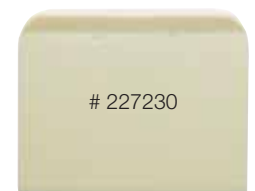



# 227231



# 227232



# 227233



# 227352



# 227355



# 227356



# 227360



# 227365



DE	TEIGSCHABER	
EN	DOUGH SCRAPER	
IT	RASCHIETTO DA IMPASTO	
ES	RASPADOR DE MASA	

#		↗ mm	→ mm	↑ mm
227231	○	137	86	1
227232	○	120	88	1
227233	○	160	120	1
227352	○	128	90	1
227852	●	128	90	1
227752	●	128	90	1
227355	○	120	80	1
227356	○	151	102	1
227856	●	151	102	1
227756	●	151	102	1
227360	○	112	78	1
227365	○	116	78	1

DE	TEIGSCHABER	
EN	DOUGH SCRAPER	
IT	RASCHIETTO DA IMPASTO	
ES	RASPADOR DE MASA	

#		↗ mm	→ mm	↑ mm
227363	○	204	151	1
227863	●	204	151	1
227763	●	204	151	1



# 227363

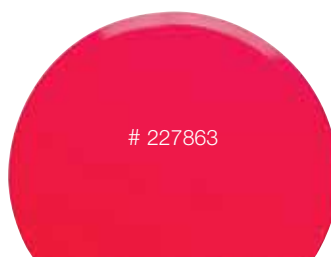

# 227863

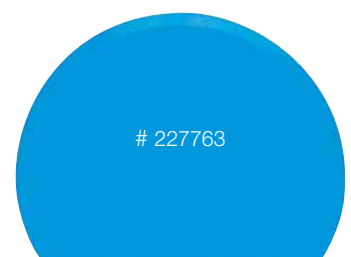

# 227763

DE	ABSTECHER	<b>SST</b>
EN	SCRAPERS	
IT	RASCHIE, INOX	
ES	CORTANTE	

- Kunststoffgriff
- Ecken abgerundet
- Plastic handle
- Round edges

#	↔ mm	
200600	110 x 120	● flexible Klinge / flexible blade
199070	110 x 120	○ flexible Klinge / flexible blade
199075	110 x 120	● flexible Klinge / flexible blade
200601	110 x 120	● steife Klinge / stiff blade
200602	130 x 135	● steife Klinge / stiff blade



# 200600



# 199070



# 199075

6

DE	ABSTECHER	<b>SST</b>
EN	SCRAPERS	
IT	RASCHIE, INOX	
ES	CORTANTE	

- Kunststoffgriff blau
- Blue plastic handle

#	↔ mm	
200702	195 x 145	Trapez / trapezoidal
200703	160 x 170	Rechteck / rectangular

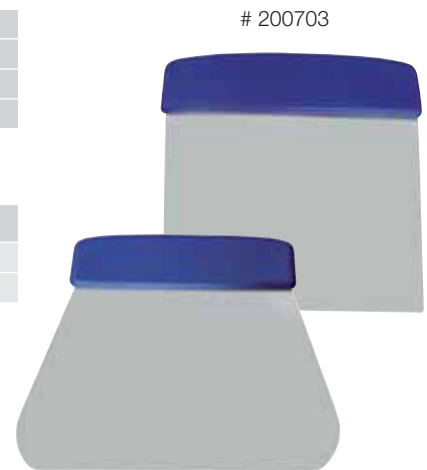

# 200702

DE	SCHABER EDELSTAHL	<b>SST</b>
EN	SCRAPERS STAINLESS STEEL	
IT	RASCHIETTI, INOX	
ES	RASQUETAS, INOX	

#	↔ mm	
154840	100 x 100	Quadrat / square
154841	110 x 110	Dreieck / triangular
154842	110 x 75	Rechteck / rectangular

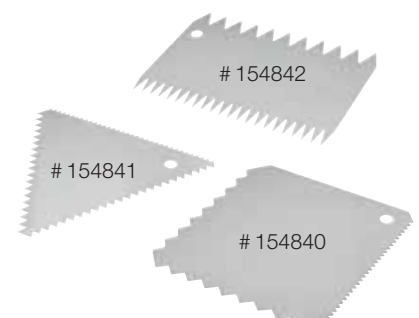



# 200502

DE	SPACHTELN	<b>SST</b>
EN	SPATULAS	
IT	SPATOLE	
ES	ESPÁTULAS	

- Kunststoffgriff schwarz (PP)
- Black plastic handle (PP)

#	→ mm	
<input checked="" type="checkbox"/> 200500	40	
<input checked="" type="checkbox"/> 200501	60	
<input checked="" type="checkbox"/> 200502	80	
<input checked="" type="checkbox"/> 200503	100	
<input checked="" type="checkbox"/> 200504	120	



# 200701

- Griff Kunststoff (PS)
- Plastic handle (PS)

#	→ mm	
<input checked="" type="checkbox"/> 200700	170	
<input checked="" type="checkbox"/> 200701	270	



# 200622

DE	ABSTECHER	<b>SST</b>
EN	SCRAPERS	
IT	RASCHIE, INOX	
ES	CORTANTES	

- Runder Griff
- With round handle

#	↔ mm	
200620	125 x 105	
200621	150 x 105	
200622	175 x 105	

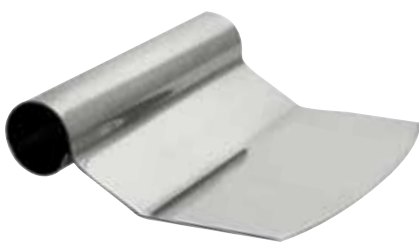

# 200611

- Materialstärke: 0,8 mm
- Thickness: 0.8 mm

#	↔ mm		
200610	120 x 115	flach / flat	
200611	120 x 110	abgerundet / oblique	



DE	SPACHTEL – EXTRA STABIL	<b>SST</b>
EN	SPATULA – EXTRA STRONG	
IT	SPATOLA – EXTRA RESISTENTE	
ES	ESPÁTULA – EXTRA RESISTENTE	

- Griff Kunststoff
- Plastic handle
- Speziell für Schokolade
- Especially for chocolate

#	→ mm	
<input checked="" type="checkbox"/> 200710	180	

DE	STIELSCHABER	
EN	SPATULAS	SI
IT	SPATOLE	
ES	ESPÁTULAS	

- Mit Metallstiel
- Hitzebeständig bis + 300 °C
- With metal handle
- Heat resistant up to + 300 °C

#	↔ mm	↗ mm
<input checked="" type="checkbox"/> 200925	● 28 x 60	210
<input checked="" type="checkbox"/> 200926	● 55 x 85	285
<input checked="" type="checkbox"/> 200927	● 70 x 115	325
<input checked="" type="checkbox"/> 200928	○ 55 x 85	285
<input checked="" type="checkbox"/> 200929	○ 70 x 115	325



- Griff aus hitzebeständigem Kunststoff bis + 260 °C
- Mit Aufhängeöse
- Handle made of heatresistant plastic, up to + 260 °C
- With hanging hole

#	↔ mm	↗ mm
<input checked="" type="checkbox"/> 200750	85 x 53	250
<input checked="" type="checkbox"/> 200751	115 x 68	350
<input checked="" type="checkbox"/> 200752	115 x 68	450



# 200751

DE	STIELSCHABER – LÖFFEL	
EN	SPATULAS – SPOON	SI
IT	SPATOLE CUCCHIAIO	
ES	ESPÁTULAS CUCHARA	

- Griff aus hitzebeständigem Kunststoff bis + 260 °C
- Mit Aufhängeöse
- Handle made of heatresistant plastic up to + 260 °C
- With hanging hole

#	↔ mm	↗ mm
<input checked="" type="checkbox"/> 200760	116 x 68	250
<input checked="" type="checkbox"/> 200761	116 x 68	350
<input checked="" type="checkbox"/> 200762	116 x 68	450



# 200761

DE	STIELSCHABER MIT THERMOMETER	
EN	SPATULA WITH THERMOMETER	
IT	SPATOLE CON TERMOMETRO	
ES	ESPÁTULA CON TERMOMETRO	

- Hitzebeständiges Silikon
- Auflösung: 0,1° C
- Genauigkeit: +/- 1°C (0° C / +100°C), sonst +/- 1%
- Fühlerlänge: 235 mm
- Heat-resistant silicone
- Resolution: 0.1° C
- Accuracy: +/- 1°C (0° C / +100°C) otherwise +/- 1%
- Probe length: 235 mm

#	°C	↔ mm
<input checked="" type="checkbox"/> 160015	-50 / +300	320 x 65





# 200771 # 200773

DE	STIELSCHABER
EN	SPATULAS
IT	SPATOLE
ES	ESPÁTULAS

Schaber: Gummi  
Griff: Holz  
Scraper: rubber  
Handle: wood

#	↗ mm	
200770	270	
200771	285	
<input checked="" type="checkbox"/> 200772	320	
<input checked="" type="checkbox"/> 200773	390	

Material: PP, weiß  
• Ideal fürs Kuchenlösen in beschichteten Backformen  
Made of PP, white  
• Ideal for loosing cakes in coated baking moulds



#	↗ mm	→ mm	↑ mm	
227099	220	35	6	



# 200420 # 200423



# 200424

Material: PP, weiß  
• Aus einem Stück  
• Sehr stabil  
Made of PP, white  
• Made of one piece  
• Very strong

#	↗ mm	→ mm	↑ mm	
<input checked="" type="checkbox"/> 200420	300	55	15	
<input checked="" type="checkbox"/> 200423	340	55	15	

Stiel: ABS, blau  
Schaber: Gummi, weiß  
• Extra stabil  
Handle made of ABS, blue  
Scraper made of rubber, white  
• Extra strong

#	↗ mm	→ mm	↑ mm	
<input checked="" type="checkbox"/> 200424	310	60	15	

DE	ABSTECHER
EN	CUTTERS
IT	TAGLIAPASTA
ES	CORTAPASTAS

Material: SAN, weiß  
Made of SAN, white



#	↗ mm	
227002	230	

DE	RÜHRSPATEL	
EN	MIXING SPATULA	
IT	SPATOLA	
ES	ESPÁTULA	

#	↗ mm	→ mm	↑ mm
<input checked="" type="checkbox"/> 200940	250	50	15
<input checked="" type="checkbox"/> 200941	300	55	15
<input checked="" type="checkbox"/> 200942	350	55	15
<input checked="" type="checkbox"/> 200943	400	65	20
<input checked="" type="checkbox"/> 200944	450	70	20
<input checked="" type="checkbox"/> 200945	500	75	20



DE	KONDITORLÖFFEL
EN	SPOONS
IT	CUCCHIAONI IN LEGNO
ES	CUCHARAS

Material: Buchenholz

Made of beech wood

#	↗ mm
203429	300
203430	350
203431	400
203432	450
203433	500
203434	600



DE	MASSENRÜHRSPATEL
EN	SPATULAS
IT	SPATOLE IN LEGNO
ES	ESPÁTULAS PARA DILUIR

Material: Buchenholz

Made of beech wood

#	↗ mm
203435	350
203436	400
203437	500





DE	STIPPROLLER
EN	ROLLER DOCKERS
IT	RULLI BUCASFOGLIA
ES	RODILLOS PARA PINCHAR HOJALDRE

Material: Edelstahl / Aluminium  
 • Mit ergonomischem Kunststoffgriff

Made of stainless steel and aluminium  
 • With ergonomic plastic handle

#	→ mm
154104	120 mm



# 200001

Material: Kunststoff (POM), elfenbein  
 • Mit verstärktem Kunststoffgriff

Made of plastic (POM), ivory  
 • With reinforced plastic handle

#	→ mm
<input checked="" type="checkbox"/> 200001	65
<input checked="" type="checkbox"/> 200002	120

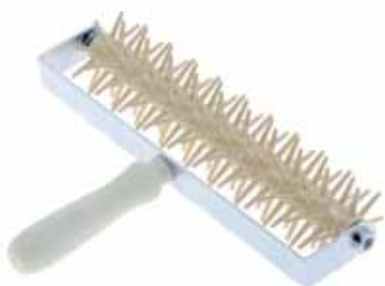

Material: Kunststoff (POM), elfenbein  
 • Ergonomischer Griff  
 • Halterung aus Metall

Made of plastic (POM), ivory color  
 • Ergonomic plastic handle  
 • Mounting made of steel

#	→ mm
200182	270



DE	STRUDELWALZEN
EN	CUTTING ROLLERS
IT	RULLI TAGLIAPASTA (PER STRUDEL)
ES	RODILLOS PARA CORTAR LA MASA

Material: Edelstahl  
 • Mit ergonomischem Kunststoffgriff

Made of stainless steel  
 • With ergonomic plastic handle

#	→ mm
154300	65



Material: Kunststoff (POM), elfenbein  
 • Mit verstärktem Kunststoffgriff  
 • Für Mürb- oder Hefeteig

Made of plastic (POM), ivory  
 • With reinforced plastic handle  
 • For short crust pastry and yeast dough

#	→ mm
<input checked="" type="checkbox"/> 200003	65

DE	GITTERSCHNEIDER
EN	LATTICE CUTTING ROLLERS
IT	RULLI PER LOSANGHE
ES	RODILLOS ROMBO

- |                                     |                                 |
|-------------------------------------|---------------------------------|
| Material: Edelstahl                 | Made of stainless steel         |
| • Mit ergonomischem Kunststoffgriff | • With ergonomic plastic handle |
| • Schneideabstand ca. 7 mm          | • Distance between blades 7 mm  |

#	→ mm
154203	120



- |                                       |                                  |
|---------------------------------------|----------------------------------|
| Material: Kunststoff (POM), elfenbein | Made of plastic (POM), ivory     |
| • Mit verstärktem Kunststoffgriff     | • With reinforced plastic handle |

#	→ mm
<input checked="" type="checkbox"/> 200004	65
<input checked="" type="checkbox"/> 200114	120

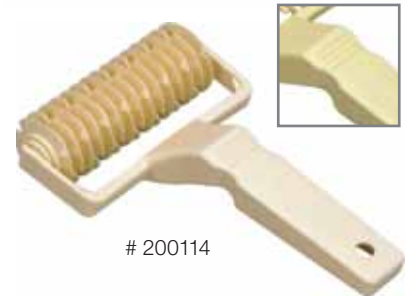

6

DE	DREIECK-AUSSTECHEWALZEN
EN	TRIANGULAR CROISSANT CUTTERS
IT	RULLI TAGLIA CROISSANTS
ES	RODILLOS PARA CORTAR CROISSANTS

- |                                 |                            |
|---------------------------------|----------------------------|
| Material: Edelstahl             | Made of stainless steel    |
| • Ergonomischer Kunststoffgriff | • Ergonomic plastic handle |
| • Für Croissants                | • For croissants           |

#		mm
154420	einfach / single	a=110, h=150
154421	einfach / single	a=180, h=140
154422	einfach / single	a=180, h=200
154424	einfach / single	a= 70, h=100
154499	einfach / single	a= 97, h=210
154427	doppelt / double	a=180, h=200
154430	dreifach / triple	a=180, h=200
154429	dreifach / triple	a=180, h=140

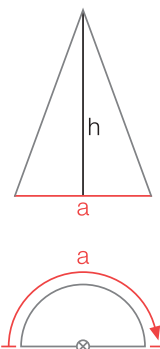
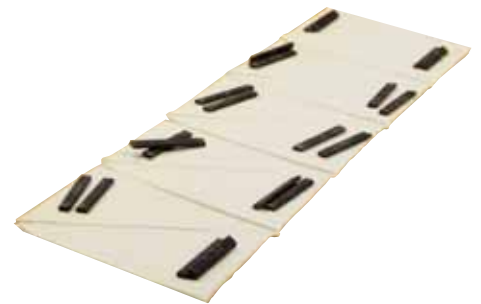

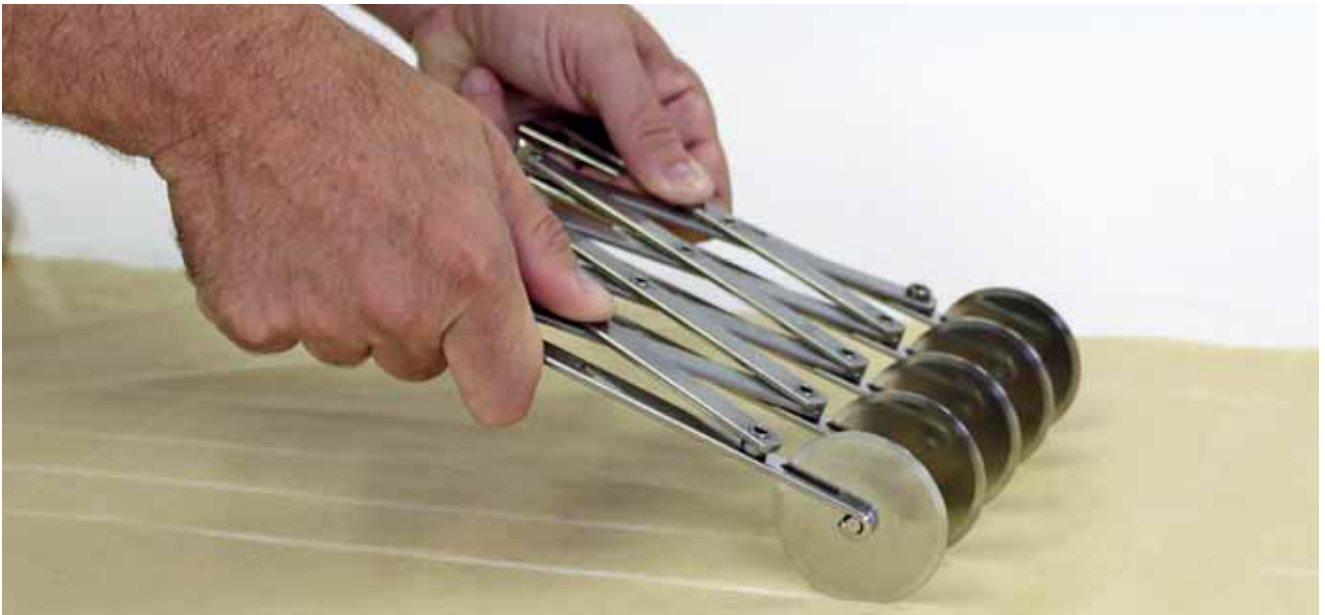

DE	TEIGSCHNEIDER „RUCK-ZUCK“	SST
EN	EXPANDABLE DOUGH CUTTERS	
IT	TAGLIAPASTA ESTENSIBILE (BICICLETTA), INOX	
ES	CORTAPASTAS EXTENSIBLE – BICICLETA	

- Rostfrei
- Sehr stabile Ausführung
- Schnittbreite max. 125 mm
- Rädchen-Durchmesser 55 mm
- Very strong quality
- Width between wheels max. 125 mm
- Wheel diameter 55 mm

#		
153100	5 Rädchen glatt / 5 wheels plain	
153110	5 Rädchen gezackt / 5 wheels serrated	
153200	7 Rädchen glatt / 7 wheels plain	
153210	7 Rädchen gezackt / 7 wheels serrated	
153204	Flügelschraube mit Mutter / wing screw with nut	

#		
153300	5 Rädchen glatt und gezackt / 5 wheels plain and serrated	
153400	7 Rädchen glatt und gezackt / 7 wheels plain and serrated	
153204	Flügelschraube mit Mutter / wing screw with nut	

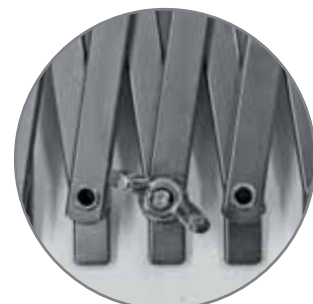

DE	TEIGSCHNEIDER	
EN	DOUGH CUTTER	SST
IT	TAGLIAPASTA ESTENSIBILE CON BASE FISSA	
ES	CORTAPASTAS REGULABLE CON BARRA FIJA	

- Rostfrei
- 8 Messer (gefedert)
- Stange 70 cm
- Inklusive Skala 60 cm
- Messerdurchmesser 5,5 cm
- 8 blades (spring-loaded)
- Rod 70 cm
- Engraved scale 60 cm
- Diameter of blades 5,5 cm

#		 kg
153450	Komplett = 8 Rädchen glatt und Stange / complete set = 8 wheels plain and rod	1,2
153451	Ersatzstange / extra rod	
153452	Ersatzmesser / extra blade	

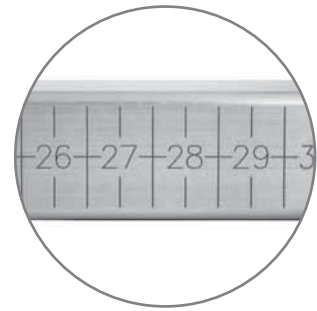

6

DE	TEIG- UND PIZZASCHNEIDER	
EN	DOUGH AND PIZZA CUTTERS	SST
IT	ROTELLE TAGLAPASTA E TAGLIAPIZZA	
ES	RULETAS CORTAMASA-CORTAPIZZA	

- Kunststoffgriff mit Handschutz
- Aufhängeöse
- Sehr robuste Ausführung
- Plastic handle and hook
- With hand protection
- Very strong quality

#		Ø mm
<input checked="" type="checkbox"/> 200005	einfach, glatt / single, plain	55
<input checked="" type="checkbox"/> 200006	einfach gewellt / single serrated	55
<input checked="" type="checkbox"/> 200007	doppelt glatt und gewellt / double, plain and serrated	55
<input checked="" type="checkbox"/> 200115	einfach, glatt / single, plain	100



DE	TEIG- UND PIZZASCHNEIDER	
EN	DOUGH AND PIZZA CUTTERS	SST
IT	ROTELLE TAGLAPASTA E TAGLIAPIZZA	
ES	RULETAS CORTAMASA-CORTAPIZZA	

- Mit ergonomischem Griff aus schwarzem PP; ca. 255 mm lang
- Ergonomic handle made of black PP; ca. 255 mm length

#		Ø mm
200116	einfach, glatt / single, plain	125



# 200160

DE	ROLLHÖLZER / TEIGROLLE
EN	ROLLING PINS
IT	RULLI IN LEGNO
ES	RODILLOS DE AMASAR EN MADERA

Material: Buchenholz  
 • Mit Präzisionskugellager

Made of beech wood  
 • With precision ball-bearing

#	→ mm (Walze / roller)	Ø mm	kg
200160	250	90	1,4
200161	300	90	1,7
200162	350	90	1,9
200163	400	90	2,1
200164	450	90	2,3



# 203300

#	↗ mm	Ø mm
203300	420	45
203310	500	45

Material: PE, weiß  
 • Hygienisch  
 • Einfach zu reinigen  
 • Mit Edelstahlwelle

Made of PE, white  
 • Hygienic  
 • Easy to clean  
 • Shaft stainless steel



# 200127

#	→ mm (Walze / roller)	Ø mm	kg
200126	300	80	1,9
200127	400	80	2,0
200128	450	80	2,3
200129	500	80	2,5

Material: PE, weiß

Made of PE, white



# 200096

#	↗ mm	Ø mm	kg
200096	300	48	0,8
200097	400	48	0,9
200123	500	48	0,6

DE	BROTSTREICHER
EN	BREAD BRUSHES
IT	SPAZZOLE PER PANE
ES	CEPILLOS PARA PAN



# 200235

Holzstiel, Kunstborste (Polyester-Faser)  
 • Mit Aufhängeloch

Wooden handle, synthetic bristle  
 • With hanging hole

#	↗ mm	
<input checked="" type="checkbox"/> 200234	245	4-reihig / 4 rows
<input checked="" type="checkbox"/> 200235	320	5-reihig / 5 rows
<input checked="" type="checkbox"/> 200236	410	6-reihig / 6 rows
<input checked="" type="checkbox"/> 200237	460	7-reihig / 7 rows



**Stabiler Kunststoffkörper mit glatter Oberfläche**, hochwertige Polyester-Borsten  
 • Hitzebeständig bis 134°C  
 • Mit Aufhängeloch

**Stable plastic body with smooth surface**, high-quality polyester bristles  
 • Heat resistant up to 134°C  
 • With hanging hole

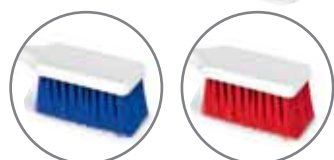

#	↗ mm	
<input checked="" type="checkbox"/> 120810	400	○
<input checked="" type="checkbox"/> 120811	400	●
<input checked="" type="checkbox"/> 120812	400	●

DE	MEHLBESEN
EN	FLOUR BRUSHES
IT	SPAZZOLE PER FARINA
ES	CEPILLOS PARA HARINA

**Holzrücken, 100% Rosshaar**

**Wooden handle, 100% horsehair**

#	↗ mm		
200238	300		hellbraun / beige
200239	300		schwarz / black



**Kunststoffrücken, Rosshaarmischung (50% Rosshaar und 50% Synthetik PVC)**

**Grip made of plastic, horsehair mixture (50% horsehair and 50% synthetic PVC)**

#	↗ mm		
200260	300		hellbraun / beige
200261	300		schwarz / black



**Stabiler Kunststoffkörper mit glatter Oberfläche, hochwertige Polyester-Borsten**  
 • Hitzebeständig bis 134°C  
 • Mit Aufhängeloch

**Stable plastic body with smooth surface, high-quality polyester bristles**  
 • Heat resistant up to 134°C  
 • With hanging hole

#	↗ mm		
<input checked="" type="checkbox"/> 120800	300		○
<input checked="" type="checkbox"/> 120801	300		●
<input checked="" type="checkbox"/> 120802	300		●



DE	REINIGUNGSBÜRSTE
EN	CLEANING BRUSH
IT	SPAZZOLA DI PULIZIA
ES	CEPILLO DE LIMPIEZA

• Holzgriff  
 • Borstenfläche ca. 13 x 2,5 cm

• Wooden handle  
 • Bristle area approx. 13 x 2.5 cm

#		↗ mm	
<input checked="" type="checkbox"/> 120950	Messingdraht / Brass wire	285	
<input checked="" type="checkbox"/> 120960	Stahldraht / Steel wire	285	



DE	BACKOFENBESEN
EN	OVEN BROOMS
IT	SPAZZOLONI DA FORNO
ES	CEPILLOS PARA HORNO

• Hitzebeständig bis + 300 °C  
 • Extra dicht besteckt  
 • Naturfaser

• Heat resistant up to + 300 °C  
 • Natural fabric

#	↔ mm		
120650	500		Besen mit Metallschaber / broom with metal scraper
120653	500		Besen / broom
120651	1900		Stiel / stick



6



DE	PINSEL
EN	BRUSHES
IT	PENNELLI
ES	PINCELES

Weißer Borsten, lebensmittelunbedenklich  
(70% Kunstborste PBT/PP und  
30% Naturschweineborste)  
• Holzstiel mit Aufhängeöse

White bristles, food safe (70% synthetic  
bristles PBT/PP and 30% natural pig  
bristles)  
• Wooden handle with hole



#	→ mm
<input checked="" type="checkbox"/> 200200	10
<input checked="" type="checkbox"/> 200201	15
<input checked="" type="checkbox"/> 200202	20
<input checked="" type="checkbox"/> 200203	25
<input checked="" type="checkbox"/> 200204	30
<input checked="" type="checkbox"/> 200205	35
<input checked="" type="checkbox"/> 200206	40
<input checked="" type="checkbox"/> 200207	50
<input checked="" type="checkbox"/> 200208	60
<input checked="" type="checkbox"/> 200209	80
<input checked="" type="checkbox"/> 200210	100



#	→ mm	Zoll / inch
<input checked="" type="checkbox"/> 200212		1/2"
<input checked="" type="checkbox"/> 200213		3/4"
<input checked="" type="checkbox"/> 200214		1"
<input checked="" type="checkbox"/> 200215		1 1/2"
<input checked="" type="checkbox"/> 200216		2"
<input checked="" type="checkbox"/> 200217		2 1/2"
<input checked="" type="checkbox"/> 200218		3"
<input checked="" type="checkbox"/> 200219		4"



Weißer Borsten, lebensmittelunbedenklich  
(70% Kunstborste PBT/PP und  
30% Naturschweineborste)  
• Kunststoffstiel mit Aufhängeöse

White bristles, food safe (70% synthetic  
bristles PBT/PP and 30% natural pig  
bristles)  
• Handle made of plastic with hanging hole

#	→ mm
<input checked="" type="checkbox"/> 200271	25
<input checked="" type="checkbox"/> 200272	30
<input checked="" type="checkbox"/> 200273	35
<input checked="" type="checkbox"/> 200274	40
<input checked="" type="checkbox"/> 200275	50
<input checked="" type="checkbox"/> 200276	60
<input checked="" type="checkbox"/> 200280	75



DE	PINSEL "SILIKON"
EN	BRUSHES "SILICONE"
IT	PENNELLI IN SILICONE
ES	PINCELES EN SILICONA

Material: Silikon, mit Metallstiel  
• 5-reihig  
• Bis + 300 °C

Made of silicone, with metal handle  
• 5 rows  
• Up to + 300 °C

#	→ mm	↗ mm
<input checked="" type="checkbox"/> 200313	35	230
<input checked="" type="checkbox"/> 200312	42	235
<input checked="" type="checkbox"/> 200299	50	280

DE	PINSEL
EN	BRUSHES
IT	PENNELLI
ES	PINCELES

Weißer Borsten, lebensmittelunbedenklich  
(50% Kunstborste PBT/PP und  
50% Naturschweineborste)

- Kunststoffstiel mit Aufhängeöse (PA)

With hanging hole, white bristles, food safe  
(50% synthetic bristles PBT/PP and  
50% natural pig bristles)

- Handle made of plastic (PA)

#	→ mm
<input checked="" type="checkbox"/> 200290	40
<input checked="" type="checkbox"/> 200291	50
<input checked="" type="checkbox"/> 200292	60
<input checked="" type="checkbox"/> 200293	75

**Superweiche Polyester-Borsten weiß**

- Stiel PA

**Super soft white polyester bristles**

- Handle made of plastic (PA)

#	→ mm
<input checked="" type="checkbox"/> 202294	40
<input checked="" type="checkbox"/> 202295	50
<input checked="" type="checkbox"/> 202296	60
<input checked="" type="checkbox"/> 202297	75



**Borsten  
in zwei  
Qualitäten**



6

DE	PINSEL
EN	BRUSHES
IT	PENNELLI
ES	PINCELES

Nylonborsten, rot

- Schwarzer Kunststoffgriff mit Aufhängeöse
- Bis 150 °C hitzebeständig

Made of nylon, red bristles

- Plastic handle with hole
- Heat-resistant up to +150 °C



#	→ mm
<input checked="" type="checkbox"/> 200285	25
<input checked="" type="checkbox"/> 200286	35
<input checked="" type="checkbox"/> 200287	50
<input checked="" type="checkbox"/> 200288	60



DE	BROTFORMEN / GÄRKÖRBE
EN	BREAD PROOFING BASKETS
IT	CESTE DA LIEVITAZIONE PER PANE
ES	CESTOS DE FERMENTACIÓN DE PAN (BANNETONES)

Material: Peddigrohr

Made of rattan

	#		 g	↑ mm *	↔ mm*	
		<b>▼ geflochtener Boden / plaited bottom</b>				
<b>A</b>	201200	Rund / round	500	75	Ø 190	
<b>B</b>	201205	Rund / round	750	80	Ø 200	
<b>C</b>	201210	Rund / round	1000	85	Ø 220	
<b>C</b>	201220	Rund / round	1500	90	Ø 250	
<b>-</b>	201230	Rund / round	2000	95	Ø 290	
<b>D</b>	201300	Oval	500	80	240 x 140	
<b>D</b>	201302	Oval	250	85	200 x 120	
<b>D</b>	201305	Oval	750	80	260 x 150	
<b>D</b>	201310	Oval	1000	95	260 x 160	
<b>E</b>	201320	Oval	1500	90	320 x 180	
<b>F</b>	201330	Oval	2000	105	360 x 200	
<b>D</b>	201400	Lang, runder Kopf / long, round shape	500	90	240 x 130	
<b>E</b>	201410	Lang, runder Kopf / long, round shape	1000	90	340 x 130	
<b>E</b>	201420	Lang, runder Kopf / long, round shape	1500	90	430 x 130	
<b>F</b>	201430	Lang, runder Kopf / long, round shape	2000	95	460 x 150	
<b>-</b>	201440	Lang, runder Kopf / long, round shape	3000	95	500 x 170	
<b>E</b>	201450	Lang, runder Kopf / long, round shape	300	55	410 x 95	
<b>E</b>	201451	Lang, runder Kopf / long, round shape	500	55	460 x 100	
<b>E</b>	201500	Lang, eckiger Kopf / long, angled shape	1000	85	320 x 130	
<b>E</b>	201510	Lang, eckiger Kopf / long, angled shape	1250	90	360 x 130	
<b>F</b>	201520	Lang, eckiger Kopf / long, angled shape	1500	85	380 x 140	
<b>A</b>	201850	Dreieck / triangle	500	80	180 x 180 x 180	
<b>B</b>	201851	Dreieck / triangle	1000	80	210 x 210 x 210	
<b>B</b>	201852	Quadrat / square	1000	80	220 x 220	
		<b>▼ Holzboden / wooden bottom</b>				
<b>D</b>	201600	Lang, runder Kopf / long, round shape	500	75	240 x 120	
<b>E</b>	201610	Lang, runder Kopf / long, round shape	1000	90	340 x 130	
<b>F</b>	201620	Lang, runder Kopf / long, round shape	1500	90	430 x 130	
<b>F</b>	201630	Lang, runder Kopf / long, round shape	2000	90	460 x 150	
<b>E</b>	201700	Lang, eckiger Kopf / long, angled shape	1000	85	320 x 130	
<b>E</b>	201710	Lang, eckiger Kopf / long, angled shape	1250	85	360 x 130	
<b>E</b>	201720	Lang, eckiger Kopf / long, angled shape	1500	90	380 x 140	
<b>F</b>	201730	Lang, eckiger Kopf / long, angled shape	2000	90	440 x 140	
		<b>▼ Holzboden speziell für Schnittenbrot / wooden bottom, especially for sandwich bread</b>				
<b>-</b>	201800	Lang, eckiger Kopf / long, angled shape	3000	95	500 x 160	
<b>-</b>	201810	Lang, eckiger Kopf / long, angled shape	4000	100	550 x 160	
<b>-</b>	201820	Lang, eckiger Kopf / long, angled shape	5000	100	600 x 160	
<b>-</b>	201830	Lang, eckiger Kopf / long, angled shape	6000	100	650 x 160	

\* Circa-Abmessungen, können leicht abweichen / \* Approximate dimensions, may vary slightly



# 201200 – 201230



# 201300 – 201330



# 201400 – 201440



# 201500 – 201520



# 201600 – 201630



# 201700 – 201730



# 201800 – 201830



# 201450 + 201451



# 201852



# 201850 + 201851



- Passende Gärtücher (Seite 118) für die jeweilige Brotform (Seite 116 und 118) sind mit einem Großbuchstaben definiert.
- Matching cotton liners (page 118) for the respective proofing basket (page 116 and 118) are defined with a capital letter.

NICHT zum Backen geeignet!  
NOT for baking!



DE	BROTFORMEN / GÄRKÖRBE
EN	BREAD PROOFING
IT	CESTE DA PANE
ES	CESTOS DE FERMENTACIÓN DE PAN

- Material: PP
- Hygienisch
  - Lebensmittelecht
  - Spülmaschinenfest
  - Reinigungsfreundlich durch undurchlässige Oberfläche
  - Stapelbar

- Made of PP
- Hygienic
  - Food safe
  - Dishwasher-proof
  - Easy cleaning due to impermeable surface
  - Stackable

	#		g	mm
<b>A</b>	201000	● rund / round	500	Ø 190
<b>B</b>	201010	● rund / round	1000	Ø 220
<b>C</b>	201020	● rund / round	1500	Ø 250
<b>D</b>	201030	● rechteckig / rectangular	500	120 x 270
<b>E</b>	201040	● rechteckig / rectangular	1000	130 x 350
<b>F</b>	201050	● rechteckig / rectangular	1500	140 x 420



DE	GÄRTÜCHER
EN	COTTON LINERS
IT	TELE COPRICESTA
ES	PAÑOS PARA CESTOS DE FERMENTACIÓN DE PAN

- Material: 95 % Baumwolle, 5 % Elastomer, weiß in 3 Größen
- Mit normalem Waschmittel ohne Weichspüler und Bleichmittel bis 40°C waschbar

- Material: cotton 95%, elastomer 5% white in 3 sizes
- Can be washed up to 40°C with normal detergent without softener and bleach

	#		mm
<b>A</b>	201901	für runde Gärkörbe / for round bread proofing baskets	190
<b>B</b>	201902	für runde Gärkörbe / for round bread proofing baskets	220
<b>C</b>	201903	für runde Gärkörbe / for round bread proofing baskets	250
<b>D</b>	201904	für rechteckige Gärkörbe / for rectangular bread proofing baskets	120 x 270
<b>E</b>	201905	für rechteckige Gärkörbe / for rectangular bread proofing baskets	130 x 350
<b>F</b>	201906	für rechteckige Gärkörbe / for rectangular bread proofing baskets	140 x 420



DE	HANDBÜRSTE SPEZIELL ZUM REINIGEN VON GÄRKÖRBE
EN	CLEANING BRUSH FOR BREAD PROOFING BASKETS
IT	SPAZZOLA PER LA PULIZIA DELLE CESTE DA LIEVITAZIONE
ES	CEPILLOS PARA LIMPIEZA DE CESTOS DE FERMENTACIÓN DE PAN

Griff aus Holz; Borsten Polyester      Wooden handle, bristles made of polyester

#	mm
201907	135 x 40 x 70

DE	BROT- UND BRÖTCHENDRÜCKER / TEIGDRÜCKER
EN	BREAD AND DOUGH MARKERS / DOUGH MARKERS
IT	STAMPI PER PANE, ROSETTA
ES	MARCADOR DE PAN ROSETA

Material: Edelstahl  
 • Stabiler Griff

Made of stainless steel  
 • Solid handle

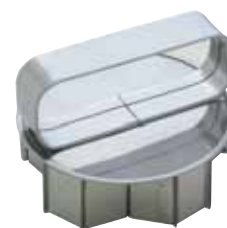

#	Ø mm	↑ mm	
199585	80	57	5-eckig / 5 square
199586	160	57	5-eckig / 5 square
199580	80	57	ohne Loch / without hole
199581	65	57	ohne Loch / without hole
199582	80	57	mit Loch / with hole



6

Material: Kunststoff, weiß

Made of plastic, white

#	
166080	Kaisersemmel gerade / straight
166081	Kaisersemmel
166082	Kaisersemmel mit Loch / with hole
166083	Spirale / spiral



DE	KAISERSEMMLDRÜCKER
EN	"KAISERSEMML", MARKERS
IT	STAMPI PER PANE, KAISER
ES	MARCADOR DE PAN DE VIENA

Material: Kunststoff, weiß

Made of white plastic

#	Ø mm	↗ mm
191095	64	200





DE	FLACHBESEN	
EN	FLAT WHISK	
IT	FRUSTA PIATTA	
ES	BATIDOR PLANO	

- Speziell für das Unterheben von schweren Massen und Saucen, Cremes und Mehl
  - Auch bestens für Fettgebäck geeignet
  - Especially for mixing heavy masses and sauces, creams and flour
  - Also ideally suitable for fatty pastries
- Drahtstärke: 2,0 mm**      **Wire thickness: 2.0 mm**

#	↗ mm	Drähte / Wires
<input checked="" type="checkbox"/> 170079	270	4



DE	SCHNEEBESEN	
EN	WHISKS	
IT	FRUSTE	
ES	BATIDORES	

- Schwarzer thermoplastischer Griff
  - Drähte aus Edelstahl
  - Wasserdichter Griff
  - Mit Aufhängeöse
  - Schwere Qualität
  - Hitzebeständig bis 150°C
  - Black thermoplastic handle
  - Wires made of stainless steel
  - Waterproof handle
  - With suspension eye
  - Heavy quality
  - Heat resistant up to 150°C
- Drahtstärke: 1,6 mm**      **Wire thickness: 1.6 mm**

#	↗ mm	Drähte / Wires
<input checked="" type="checkbox"/> 170080	250	24
<input checked="" type="checkbox"/> 170081	300	24
<input checked="" type="checkbox"/> 170082	350	24
<input checked="" type="checkbox"/> 170083	400	24
<input checked="" type="checkbox"/> 170084	450	24
<input checked="" type="checkbox"/> 170085	500	24



- Material: Edelstahl      Made of stainless steel
- Handlicher Griff
  - Für leichte Massen
  - Easy-to-hold handle
  - For light masses
- Drahtstärke: 1,6 mm**      **Wire thickness: 1.6 mm**

#	↗ mm	Drähte / Wires
<input checked="" type="checkbox"/> 170040	250	24
<input checked="" type="checkbox"/> 170041	300	24
<input checked="" type="checkbox"/> 170042	350	24
<input checked="" type="checkbox"/> 170043	400	24
<input checked="" type="checkbox"/> 170044	450	24



- BALLONFORM
  - Schwarzer Kunststoffgriff "Exoglass"
  - Drähte aus Edelstahl
  - Wasserdichter Griff
  - Griffbund verhindert abrutschen
  - Hitzebeständig bis 220 °C
  - BALLOON-SHAPE
  - Black plastic handle "Exoglass"
  - Wires made of stainless steel
  - Waterproof handle
  - Handle band prevents slipping
  - Heat resistant up to 220 °C
- Drahtstärke: 1,5 mm**      **Wire thickness: 1.5 mm**

#	↗ mm	Drähte / Wires
170016	450	24

DE	RÜHRBESEN	
EN	WHISKS	
IT	FRUSTE	
ES	BATIDORES	

- |   |   |
|---|---|
| <ul style="list-style-type: none"> <li>• Schwarzer thermoplastischer Griff</li> <li>• Drähte aus Edelstahl</li> <li>• Wasserdichter Griff</li> <li>• Mit Aufhängeöse</li> <li>• Schwere Qualität</li> <li>• Hitzebeständig bis 150°C</li> </ul> <p><b>Drahtstärke: 2,0 mm</b></p> | <ul style="list-style-type: none"> <li>• Black thermoplastic handle</li> <li>• Wires made of stainless steel</li> <li>• Waterproof handle</li> <li>• With suspension eye</li> <li>• Heavy quality</li> <li>• Heat resistant up to 150°C</li> </ul> <p><b>Wire thickness: 2.0 mm</b></p> |
|---|---|



#	↗ mm	Drähte / Wires
<input checked="" type="checkbox"/> 170070	250	16
<input checked="" type="checkbox"/> 170071	300	16
<input checked="" type="checkbox"/> 170072	350	16
<input checked="" type="checkbox"/> 170073	400	16
<input checked="" type="checkbox"/> 170074	450	16
<input checked="" type="checkbox"/> 170075	500	16

- |   |   |
|---|---|
| <p>Material: Edelstahl</p> <ul style="list-style-type: none"> <li>• Handlicher Griff</li> <li>• Für schwere Massen</li> </ul> <p><b>Drahtstärke: 2,3 mm</b></p> | <p>Made of stainless steel</p> <ul style="list-style-type: none"> <li>• Easy-to-hold handle</li> <li>• For heavy masses</li> </ul> <p><b>Wire thickness: 2.3 mm</b></p> |
|---|---|



#	↗ mm	Drähte / Wires
<input checked="" type="checkbox"/> 170050	350	16
<input checked="" type="checkbox"/> 170051	400	16
<input checked="" type="checkbox"/> 170052	450	16
<input checked="" type="checkbox"/> 170053	500	16
<input checked="" type="checkbox"/> 170054	600	16

- |   |  |
|---|--|
| <ul style="list-style-type: none"> <li>• Schwarzer Kunststoffgriff "Exoglass"</li> <li>• Drähte aus Edelstahl</li> <li>• Wasserdichter Griff</li> <li>• Griffbund verhindert abrutschen</li> <li>• Hitzebeständig bis 220 °C</li> </ul> <p><b>Drahtstärke: 1,8 mm</b></p> | <ul style="list-style-type: none"> <li>• Black plastic handle "Exoglass"</li> <li>• Wires made of stainless steel</li> <li>• Waterproof handle</li> <li>• Handle band prevents slipping</li> <li>• Heat resistant up to 220 °C</li> </ul> <p><b>Wire thickness: 1.8 mm</b></p> |
|---|--|



#	↗ mm	Drähte / Wires
170010	250	12
170011	300	16
170012	350	16
170013	400	16
170014	450	18
170015	500	18



DE	TEIGWANNE				
EN	DOUGH CONTAINER	PP	-20 +90 °C		
IT	CONTENITORE PER IMPASTO				
ES	CUBETA PARA MASA				

- Mit 2 Seitengriffen
- With 2 side handles

#	→□← mm	↔ mm	↑ mm	
202180	600 x 400 x 82	500 x 300 x 77	13,0	



DE	DECKEL				
EN	LID	PP	-20 +90 °C		
IT	COPERCHIO				
ES	TAPA				

- Passend für # 202180
- Suitable for # 202180

#	↗ mm	→ mm	↑ mm	für/for #
202181	600	400	35	202180



Deckel ist beidseitig verwendbar / Lid can be used on both sides

6

DE	TEIGWANNE				
EN	DOUGH CONTAINER	HDPE	-10 +40 °C		
IT	CONTENITORE PER IMPASTO				
ES	CUBETA PARA MASA				

#	→□← mm	↔ mm	↑ mm	
200960	530 x 410 x 140	440 x 320 x 130	20,0	
200962	440 x 320 x 155	395 x 275 x 150	12,0	
200963	610 x 440 x 150	550 x 375 x 145	25,0	



#200962

DE	TEIGWANNE				
EN	DOUGH CONTAINER	LDPE	-15 +60 °C		
IT	CONTENITORE PER IMPASTO				
ES	CUBETA PARA MASA				

- Mit 2 Seitengriffen
- With 2 side handles

#	→□← mm	↔ mm	↑ mm	
200970	Ø 450 x 175	Ø 270 x 172	14,0	



DE	TEIGWANNE				
EN	DOUGH CONTAINER	HDPE	-40 +90 °C		
IT	CONTENITORE PER IMPASTO				
ES	CUBETA PARA MASA				

#	→□← mm	↔ mm	↑ mm	
200971	Ø 480 x 160	Ø 380 x 155	19,0	





DE	SCHÜSSELN
EN	BOWLS
IT	BACINELLE
ES	CALDEROS

Material: PP, weiß  
 • Tiefe Form

Made of PP, white  
 • Deep form

#	Ø mm	↑ mm	↓ mm	↑ mm
221020	160	78		0,75
221021	200	96		1,6
221022	240	110		2,6
221023	280	125		4,5
221024	320	140		6,5
221025	360	162		9,5
221026	400	168		12,5



DE	SEIHER
EN	STRAINER
IT	COLAPASTA
ES	COLADOR

Material: PP, weiß  
 • 2 Muschelgriffe, passende Schüssel  
 # 221026 + 290040

Made of PP, white  
 • 2 shell shaped handles, suitable bowls  
 # 221026 + 290040

#	↑ Ø mm	↓ Ø mm	↑ mm
200022	360	280	185



DE	KASSEROLLE
EN	SAUCEPAN
IT	CARAFFA GRADUATA
ES	CAZO DE POLIPROPILENO



Material: PP, weiß  
 • Mit geprägter Skala in Innenseite  
 • Blauer Skalendruck auf der Außenseite  
 • Bruchsicher  
 • Hygienisch  
 • Für Mikrowellengeräte geeignet

Made of PP, white  
 • Inside scale  
 • Blue stamped litre and ml scale outside  
 • Break resistant  
 • Hygienic  
 • Suitable for microwave

#	↗ mm	Ø mm	↑ mm	↓ mm
290200	335	190	120	2,0

**i** Ausgießer beidseitig somit für Links- und Rechtshänder geeignet. /  
 Pour spouts on both sides, thus for left- and right-handers.



DE	WANDAUFHÄNGER
EN	WALL RACK
IT	SUPPORTO MURALE PER CONTENITORI
ES	SOPORTE MURAL PARA CONTENEDORES

Weiß beschichtet (Polyamid), passend für Dosen 2,0 l, 3,0 l und 5,0 l (# 230102, 230112 und 230122)  
 • Sehr stabile Ausführung

Coated in white plastic (Polyamide), suitable for containers 2.0 l, 3.0 l and 5.0 l (# 230102, 230112 and 230122)  
 • Solid

#	↗ mm	→ mm	↑ mm
230130	900	190	160

DE	VORRATSDOSEN
EN	STORAGE CONTAINERS
IT	CONTENITORI
ES	CONTENEDORES

- Material: PP
- Alle Größen stapelbar
  - Bruchstabil
  - Dose ohne Deckel

- Made of PP
- All sizes stackable
  - Break resistant
  - Container without lid

#	↗ mm	→ mm	↑ mm	l 
230102	175	140	150	2,0
230112	175	140	210	3,0
230122	175	140	340	5,0



DE	DECKEL FÜR VORRATSDOSEN	
EN	LID FOR STORAGE CONTAINERS	
IT	COPERCHIO PER CONTENITORI	
ES	TAPA PARA CONTENEDORES	

- Material: PP
- Bruchstabil

- Made of PP
- Break resistant

#	für Artikel / for article
230129	# 230102 / 230112 / 230122



6

DE	VORRATSDOSEN / GEWÜRZDOSEN	
EN	STORAGE CONTAINERS	
IT	CONTENITORI CON COPERCHIO	
ES	CONTENEDORES CON TAPA	

- Material: PS, transparent
- Inklusive Deckel
  - Spülmaschinengeeignet

- Made of PS, transparent
- Including lid
  - Dishwasher safe

**Rund**

**Round**

#	Ø mm	↑ mm	ml 
152919	115	140	1000
152915	115	190	1450
152916	115	280	2200



**Quadratisch**

**Square**

#	↗ mm	→ mm	↑ mm	ml 
152920	105	105	140	1000
152917	105	105	190	1450
152918	105	105	280	2000



DE	RÜHRSCHÜSSELN	SST
GB	MIXING BOWLS	
IT	BACINELLE CONICHE	
ES	CALDEROS CÓNICOS	



- **Konische Form**
- Mit abgerundetem Rand
- Glatter Boden
- Gute Standfestigkeit
- Stabil und griffig
- Stapelbar

- **Conical shape**
- With rolled edge
- Smooth bottom
- Good stability
- Stable and non-slip
- Stackable



#	Ø mm	l	
199002	160	0,5	
199003	180	0,9	
199004	200	1,2	
199005	225	1,6	
199006	235	2,0	
199007	280	3,0	
199008	320	5,0	
199009	360	7,0	
199010	395	8,2	

DE	SCHLAGSCHÜSSELN	SST
GB	MIXING BOWLS	
IT	BACINELLE SEMISFERICHE	
ES	CALDEROS SEMIESFÉRICOS	







- **Runde Form**
- Mit abgerundetem Rand
- Glatter Boden
- Gute Standfestigkeit
- Stabil und griffig
- Stapelbar

- **Hemispherical shape**
- With rolled edge
- Smooth bottom
- Good stability
- Stable and non-slip
- Stackable



#	Ø mm (innen/inside)	l	
199000	125	0,3	
199011	140	0,5	
199012	165	0,9	
199013	185	1,25	
199014	200	1,85	
199015	230	2,6	
199017	255	3,2	
199018	280	4,5	
199019	330	8,5	





DE	MASCHINENSCHLAGKESSEL	   
EN	KETTLE FOR MIXING MACHINE	
IT	CIOTOLA PER MONTARE	
ES	TAZÓN PARA BATIR	

- Mit 2 Seitengriffen
- Mit bordiertem Rand
- With 2 side handles
- With rolled rim

#	Ø mm	↑ mm	↓ mm	↓ mm
199420	260	200	10,0	1,0
199421	300	250	16,0	1,0
199422	320	300	20,0	1,0
199423	360	285	25,0	1,2
199424	360	350	32,0	1,2
199425	400	355	40,0	1,2



#199420

DE	HANDSCHLAGKESSEL	   
EN	MIXING BOWL	
IT	CIOTOLA PER MONTARE	
ES	TAZÓN PARA BATIR	

- Mit 2 Seitengriffen
- Mit bordiertem Rand
- With 2 side handles
- With rolled rim

#	Ø mm	↑ mm	↓ mm	↓ mm
199400	220	120	2,7	1,0
199401	260	140	4,0	1,0
199402	320	180	9,5	1,0
199403	360	205	14,0	1,0
199404	400	215	18,0	1,0



#199402

DE	FUSS	  
EN	BASE	
IT	BASE	
ES	BASE	

- Passend für Handschlagkessel
- Suitable for mixing bowl

#	Ø mm	↑ mm	für/for #
199406	160	40	199400, 199401
199405	220	45	199402, 199403, 199404



#199405



DE	TRICHTER
EN	FUNNELS
IT	IMBUTI
ES	EMBUDOS

Material: HDPE, natur

Made of HDPE

- Mit Entlüftungslippen und Aufhängeöse

- With air vent and suspension loop

#	Ø mm	Auslaufende / outlet Ø mm
250001	50	3
250002	60	8
250003	80	11
250004	100	12
250005	120	12
250006	140	15
250007	164	17



- Mit Überlauftrand und Phosphorsieb
- Aufhängeöse

- With overflow rim, phosphorsieve
- Suspension loop

250008	168	17
250009	208	20



#200196

DE	DOSIERFLASCHE / ENGHALSFLASCHE
EN	BOTTLES
IT	FLACONI
ES	BOTELLAS



Material: PE, transparent  
• Lebensmittelecht

Made of PE, transparent  
• Food safe

#	l	Ø mm	↑ mm
200194	0,05	28 x 51	79
200195	0,25	61	134
200196	0,5	78	162
200197	1,0	97,5	223,5



DE	SPRÜHFLASCHE
EN	SPRAYING BOTTLES
IT	FLACONI PER BAGNE
ES	BOTELLAS PARA BAÑAR BISCOCHOS



Material: PE, transparent  
• Lebensmittelecht  
• Verschluss gelocht (13 Löcher)  
• Mit Skala

Made of PE, transparent  
• Food-proof  
• Perforated cap (13 holes)  
• With scale

#	l	Ø mm	↑ mm
200192	1,0	80	290

DE	QUETSCHFLASCHE				
EN	SQUEEZE BOTTLE		PP	-20 +100 °C	
IT	BOTTIGLIA ESPRIMIBILE				
ES	BOTELLA ESPRIMIBLE				

- Mit Schraubdeckel
- Integrierte Skala
- With srew-on lid
- Integrated scale

#	Ø mm	↑ mm	l	mm	
200499	70	240	0,7	21 x 1	



DE	DRUCKPUMPZERSTÄUBER				
EN	COMPRESSED AIR SPRAYER		PP	HDPE	
IT	POLVERIZZATORE CON POMPA A PRESSIONE				
ES	PULVERIZADOR DE BOMBA DE PRESIÓN				

- Mit Dauersprühfunktion
- ErgoGrip, extra langer Komfortgriff
- Integrierte Skala
- Transparente Füllstandsanzeige
- Sprühwinkel bei feiner Zerstäubung: 60 °
- Sprühlänge bei Vollstrahl: 4 Meter
- Förderleistung: 300 ml/min
- Maximaler Betriebsdruck: 4 bar
- Maximale Betriebstemperatur: -5 bis +30 °C
- With permanent spray function
- ErgoGrip, extra long comfort handle
- Integrated scale
- Transparent fill level indicator
- Spray angle with fine atomization: 60 °
- Spray length with full jet: 4 meters
- Pumping capacity: 300 ml/min
- Maximum operating pressure: 4 bar
- Maximum operating temperature: -5 to +30 °C

#	↗ mm	→ mm	↑ mm	l	
153950	233	135	313	1,8	

Nur in Anwendung mit wasserbasierenden Flüssigkeiten! / Only for use with water-based liquids!



6

DE	DRUCKPUMPZERSTÄUBER				
EN	COMPRESSED AIR SPRAYER		PP	HDPE	
IT	POLVERIZZATORE CON POMPA A PRESSIONE				
ES	PULVERIZADOR DE BOMBA DE PRESIÓN				

- ErgoGrip, extra langer Komfortgriff
- Standring mit SoftTouch-Boden
- Integrierte Skala
- Transparente Füllstandsanzeige
- Sprühwinkel bei feiner Zerstäubung: 60 °
- Sprühlänge bei Vollstrahl: 4 Meter
- Förderleistung: 300 ml/min
- Maximaler Betriebsdruck: 3 bar
- Maximale Betriebstemperatur: -5 bis +30 °C
- ErgoGrip, extra long comfort handle
- Stand ring with SoftTouch base
- Integrated scale
- Transparent fill level indicator
- Spray angle with fine atomization: 60 °
- Spray length with full jet: 4 meters
- Delivery rate: 300 ml/min
- Maximum operating pressure: 3 bar
- Maximum operating temperature: -5 to +30 °C

#	↗ mm	→ mm	↑ mm	l	
153952	206	119	313	1,2	



Die Literangabe bezieht sich bis zur Kante.  
The liter specification refers to the edge.



DE	ZUCKERTOPF
EN	SUGAR POT
IT	PENTOLA PER ZUCCHERO
ES	OLLA PARA AZÚCAR

- Mit Kupfergriff
- With copper handle

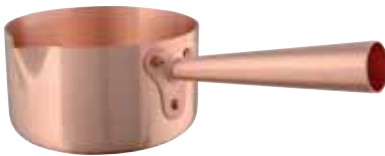

#170137

#	Ø mm	↑ mm	↓ mm	↑ mm	↓ mm
170135	120	75	0,8	2,0	
170136	140	80	1,2	2,0	
170137	160	95	1,9	2,0	
170138	180	105	2,6	2,0	
170139	200	110	3,4	2,0	

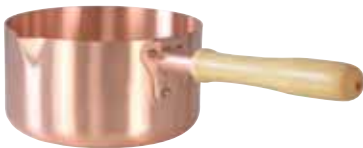

- Mit Holzgriff
- With wooden handle

#	Ø mm	↑ mm	↓ mm	↑ mm	↓ mm
170145	160	95	1,9	2,0	



DE	ZABAIONESCHÜSSEL
EN	ZABAGLIONE BOWL
IT	CIOTOLA PER ZABAIONE
ES	CUENCO PARA ZABAGLIONE

- Mit Messinggriff
- With brass handle



#	Ø mm	↑ mm	↓ mm	↑ mm	↓ mm
170140	160	125	1,9	1,2	



DE	KONFITÜRENSCHÜSSEL
EN	JAM BOWL
IT	CIOTOLA PER MARMELLATA
ES	CUENCO PARA MERMELADA

- Mit 2 Seitengriffen
- With 2 side handles
- Mit bordiertem Rand
- With rolled rim



#170120

#	↑ Ø mm	↓ Ø mm	↑ mm	↓ mm	↑ mm	↓ mm
170120	360	300	120	10,0	1,2	
170121	380	310	140	13,8	1,2	

Die Literangabe bezieht sich bis zur Kante.  
The liter specification refers to the edge.



DE	SIRUPSCHÜSSEL
EN	SYRUP BOWL
IT	CIOTOLA PER SCIROPPO
ES	CUENCO PARA SIROPE

- Mit 2 Seitengriffen
- Mit bordiertem Rand
- With 2 side handles
- With rolled rim

#	↑ Ø mm	↓ Ø mm	↑ mm	l mm	↓ mm
170116	260	150	125	5,0	1,0
170117	300	170	140	8,5	1,0
170118	350	170	150	10,1	1,0



#170117



DE	EIWEISSCHÜSSEL
EN	EGG WHITE BOWL
IT	CIOTOLA PER ALBUME D'UOVA
ES	CUENCO PARA CLARA DE HUEVO

- Mit Aufhängering
- Mit bordiertem Rand
- With hanging ring
- With rolled rim

#	Ø mm	↑ mm	l mm	↓ mm
170107	240	130	3,5	1,0
170108	260	140	4,6	1,0
170109	300	165	7,1	1,0
170110	350	165	11,1	1,0
170111	400	195	16,6	1,2



#170109

- Mit 2 Seitengriffen
- Mit bordiertem Rand
- With 2 side handles
- With rolled rim

#	Ø mm	↑ mm	l mm	↓ mm
170112	260	140	4,6	1,0
170113	300	165	7,1	1,0
170114	350	165	11,1	1,0
170115	400	195	16,6	1,2



#170113

DE	HALTERUNG	<b>SST</b>
EN	HOLDER	
IT	SUPPORTO	
ES	SUPPORTE	

- Passend für Eiweißschüsseln
- Suitable for egg white bowls

#	↑ Ø mm	↓ Ø mm	↑ mm	↓ mm
170101	155	230	105	5,0





DE	MEHL- UND GEWÜRZSCHAUFELN
EN	FLOUR SCOOPS
IT	SESSOLE
ES	RECOGEDORES LIBRADORES PARA HARINA Y CONDIMENTOS

Material: PE, Farbe natur

Made of PE , transparent

#	↗ mm	↻ ml	
200023	187	110	
200024	250	230	
200025	310	470	
200026	350	725	
200027	400	1390	

**i** HACCP-Farben auf Anfrage. / HACCP-colors open request.



Material: PE, schwarz

Made of PE , black

#	↗ mm	↻ ml	
200802	250	230	



© Wolfgang Mücke – stock.adobe.com



DE	MESSSCHAUFELN, FREI STEHEND
EN	MEASURING SCOOPS, FREE STANDING
IT	SESSOLE CON BASE PIATTA
ES	RECOGEDORES LIBRADORES CON BASE PLANA

Material: PP, weiß

Made of PP, white

- Ausführung: stehende Schaufel,
- Auch für Flüssigkeiten

- Also execution: free-standing scoops
- Suitable for liquids

#		↗ mm	↻ ml	
200350	○ weiß / white	135	25	
200351	○ weiß / white	160	50	
200352	○ weiß / white	200	100	
200353	○ weiß / white	260	250	
200354	○ weiß / white	315	500	
200355	○ weiß / white	385	1000	
200346	● rot / red	200	100	
200347	● rot / red	260	250	
200348	● blau / blue	200	100	
200349	● blau / blue	260	250	





DE	MESSBECHER
EN	MEASURING CUPS
IT	CARAFFE GRADUATE
ES	JARRAS GRADUADAS

- Material: PP, Farbe natur
- Mit geprägter Skala und blauer Skala
  - Liter- und Milliliter-Einteilung
  - Bis 95°C erhitzzbar

- Made of PP, translucent
- With stamped and blue scale
  - Litre and ml scale
  - Temperature resistant up to 95°C

**Mit geschlossenem Griff**

**With closed handle**

#		I	
206010*	ohne Griff / without handle	0,12	
200011	mit geschlossenem Griff / closed handle	0,5	
200012	mit geschlossenem Griff / closed handle	1,0	
200013	mit geschlossenem Griff / closed handle	2,0	
200014	mit geschlossenem Griff / closed handle	3,0	
200015	mit geschlossenem Griff / closed handle	5,0	

**Mit offenem Griff**

**With open handle**

#		I	
200010*	mit offenem Griff / open handle	0,25	
206011	mit offenem Griff / open handle	0,5	
206012	mit offenem Griff / open handle	1,0	
206013	mit offenem Griff / open handle	2,0	
206014	mit offenem Griff / open handle	3,0	
206015	mit offenem Griff / open handle	5,0	

\* nur geprägte Skala

\* only with stamped scale



DE	MESSBECHER-DECKEL
EN	LIDS FOR MEASURING CUPS
IT	COPERCHI PER CARAFFE GRADUATE
ES	TAPAS PARA JARRAS GRADUADAS



#	Deckel für # / Lid for #
206112	200012 + 206012 / 1,0 l
206113	200013 + 206013 / 2,0 l
206114	200014 + 206014 / 3,0 l
206115	200015 + 206015 / 5,0 l

DE	MESSBECHER-SET
EN	SET OF MEASURING CUPS
IT	SET DI CARAFFE GRADUATE
ES	SET DE JARRAS GRADUADAS

- Material: PP, Farbe natur
- Mit geprägter Skala und blauer Skala
  - Liter- und Milliliter-Einteilung
  - Bis 95°C erhitzzbar

- Made of PP, translucent
- With stamped and blue scale
  - Litre and ml scale
  - Temperature resistant up to 95°C

**Mit geschlossenem Griff, inklusive Deckel**

**With closed handle, including lid**

#		I	
200408	mit geschlossenem Griff / closed handle	1,0	
200409	mit geschlossenem Griff / closed handle	2,0	



DE	MESSBECHER
EN	MEASURING CUPS
IT	CARAFFE GRADUATE, IMPILABILI
ES	JARRAS GRADUADAS, APILABLES

- Material: PP, Farbe natur
- Mit offenem Griff
  - Stapelbar
  - Liter- und Milliliter-Einteilung
  - Bis 95°C erhitzbar

- Made of PP, translucent
- With open handle
  - Stackable
  - With litre and ml scale
  - Temperature resistant up to 95°C

#	l	ml
200149	0,5	
200150	1,0	
200170	2,0	
200179	3,0	



DE	GLASURTRICHTER
EN	GLAZE FUNNEL
IT	IMBUTO PER GLASSA
ES	EMBUDO PARA GLASEADO

- Material: Griff und Trichter aus Edelstahl
- Boden: Kunststoff
  - Lochdurchmesser: 5 mm
  - Für flüssiges Fondant mit Dosiermechanik

- Handle and funnel made of stainless steel
- Bottom made of plastic
  - Hole diameter: 5 mm
  - For liquid fondant, dosing mechanism

#	l	Ø mm	↑ mm
199960	1,0	135	150



6



geöffnet – Ansicht von innen  
open – interior view



geöffnet / open



geschlossen / closed

DE	EINHANDSIEB / DRÜCKSIEB FÜR PUDERZUCKER UND KAKAO
EN	SIEVES FOR POWDERED SUGAR AND COCOA
IT	SETACCI PER ZUCCHERO A VELO E CACAO
ES	TAMICES PARA AZÚCAR GLASS Y CACAO

Material: Edelstahl

Made of stainless steel

#	Ø mm
199069	100



DE	MEHLSIEBE, PUDER- UND ZUCKERSIEBE / RUNDSIEBE
EN	FLOUR AND SUGAR SIEVES
IT	SETACCI PER FARINA E ZUCCHERO
ES	TAMICES PARA HARINA Y AZÚCAR

Material: Ring und Metallgewebe aus Edelstahl  
 • Feines Gewebe  
 • Für trockenes Siebgut

Ring and meshes made of stainless steel  
 • Fine meshes  
 • For dry ingredients



	#	∅ mm	↑ mm	⊞ mm	⊚ mm		
<b>B</b>	199210	220	55	0,45	0,22	Mehl, sehr fein/ flour, very fine	
<b>E</b>	199211	220	55	0,60	0,25	Mehl, fein / flour, fine	
<b>F</b>	199212	220	55	0,84	0,28	Mehl, mittel / flour, medium	



<b>B</b>	199220	400	80	0,45	0,22	Mehl, sehr fein/ flour, very fine	
<b>E</b>	199221	400	80	0,60	0,25	Mehl, fein / flour, fine	
<b>F</b>	199222	400	80	0,84	0,28	Mehl, mittel / flour, medium	
<b>L</b>	199223	400	80	6,8	1,0	Streusel, grob / coarse	



<b>A</b>	199052	160	65	0,3	0,16	Mehl, sehr fein/ flour, very fine	
<b>A</b>	199053	190	65	0,3	0,16	Mehl, sehr fein/ flour, very fine	
<b>A</b>	199054	210	65	0,3	0,16	Mehl, sehr fein/ flour, very fine	
<b>A</b>	199055	240	65	0,3	0,16	Mehl, sehr fein/ flour, very fine	
<b>A</b>	199056	260	65	0,3	0,16	Mehl, sehr fein/ flour, very fine	
<b>A</b>	199057	280	65	0,3	0,16	Mehl, sehr fein/ flour, very fine	
<b>A</b>	199058	300	65	0,3	0,16	Mehl, sehr fein/ flour, very fine	

	⊞ mm	⊚ mm
<b>A</b>	0,30	0,16

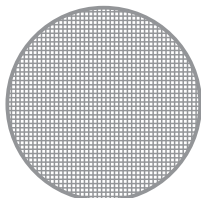

	⊞ mm	⊚ mm
<b>B</b>	0,45	0,22

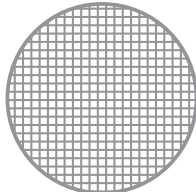

	⊞ mm	⊚ mm
<b>C</b>	0,50	0,20

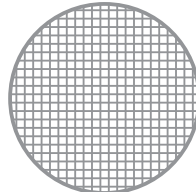

	⊞ mm	⊚ mm
<b>D</b>	0,50	0,5

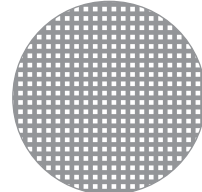

DE	MEHLSIEBE, PUDER- UND ZUCKERSIEBE / RUNDSIEBE
EN	FLOUR AND SUGAR SIEVES
IT	SETACCI PER FARINA E ZUCCHERO
ES	TAMICES PARA HARINA Y AZÚCAR

Material: PP, weiß

- Stabiler Kunststoff
- Mit praktischen Rillen (verhindert das Abrutschen)
- **Keine Metallklammern**
- Spülmaschinentauglich
- Einfach zu reinigen

Made of PP, white

- Solid plastic
- With convenient flutes (avoid slip off)
- **No staples**
- Dishwasher proof
- Easy to clean

Maschen aus Edelstahl

Stainless steel mesh

	#	Ø mm	↑/↔ mm	⊞ mm	⊞ mm
<b>C</b>	200635	185	107 / 95	0,50	0,20

<b>C</b>	200634	305	115 / 100	0,50	0,20
<b>G</b>	200633	305	115 / 100	0,85	0,24
<b>I</b>	200632	305	115 / 100	1,20	0,28
<b>J</b>	200631	305	115 / 100	1,80	0,34
<b>K</b>	200630	305	115 / 100	2,80	0,45

Maschen aus Nylon

Nylon meshes

	#	Ø mm	↑/↔ mm	⊞ mm	⊞ mm
<b>D</b>	200240	240	80 / 65	0,5	0,5
<b>H</b>	200241	240	80 / 65	1,0	0,5
<b>D</b>	200300	300	90 / 70	0,5	0,5
<b>H</b>	200301	300	90 / 70	1,0	0,5



6

	⊞ mm	⊞ mm
<b>E</b>	0,60	0,25

	⊞ mm	⊞ mm
<b>F</b>	0,84	0,28

	⊞ mm	⊞ mm
<b>G</b>	0,85	0,24

	⊞ mm	⊞ mm
<b>H</b>	1,0	0,50

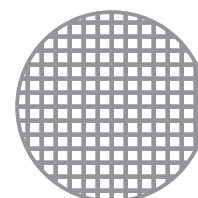
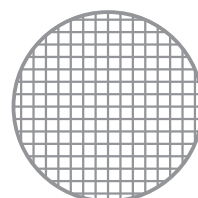
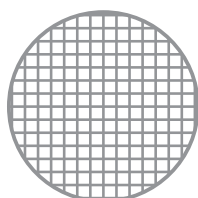
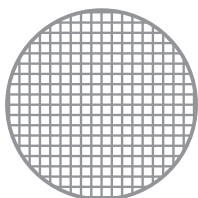

	⊞ mm	⊞ mm
<b>I</b>	1,20	0,28

	⊞ mm	⊞ mm
<b>J</b>	1,80	0,34

	⊞ mm	⊞ mm
<b>K</b>	2,80	0,45

	⊞ mm	⊞ mm
<b>L</b>	6,8	1,0

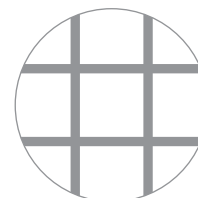
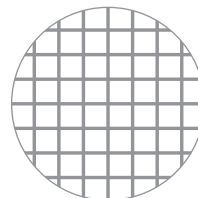
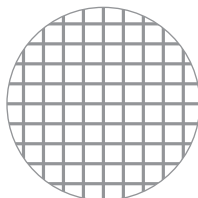
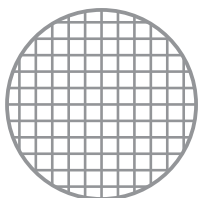



DE	AUSBACKSCHIESSER
EN	OVEN PEELS
IT	PALE PER FORNO
ES	PALAS PARA HORNEAR

Material: Aluminium  
 • Randhöhe: 30 mm  
 • Aufnahme-Stiel: 26 x 26 mm

Made of aluminium  
 • Height of edge: 30 mm  
 • Support shaft: 26 x 26 mm

#	↔ mm
155500	580 x 470



DE	STIELE	
EN	HANDLES	
IT	MANICI	
ES	PALOS	

Material: Buchenholz

Made of beech wood

#	↗ mm
203421	1600
203422	1950

DE	HANDSCHIESSER
EN	OVEN PEELS
IT	PALE PER FORNO
ES	PALAS PARA HORNEAR

Material: Buchenholz

Made of beech wood

#	↗ mm	→ mm	
203411	500	120	
203412	500	140	
203413	500	160	
203414	500	180	
203415	950	180	
203416	950	200	
203417*	1150	180	
203418*	1150	200	



DE	BREZELSCHIESSER
EN	OVEN PEELS
IT	PALE PER FORNO
ES	PALAS PARA HORNEAR

Material: Buchenholz

Made of beech wood

#	↗ mm	→ mm	
203419	600 ohne Loch / without holes	140	
203420	600 mit Loch / with holes	140	



6

DE	AUSBACKSCHIESSER
EN	OVEN PEELS
IT	PALE PER FORNO
ES	PALAS PARA HORNEAR

Material: Buchenholz

Made of beech wood

#	↗ mm	→ mm	
203400	500	120	
203401	500	140	
203402	500	160	
203403	500	180	
203404	500	200	
203405	500	240	
203406	500	300	
203407	500	320	
203408	500	340	
203409	600	160	
203410	650	200	





DE	TORTENRINGE RUND
EN	TART RINGS ROUND
IT	ANELLI PER TORTE
ES	AROS PARA TARTAS

Material: Edelstahl

Made of stainless steel

**Mit Borde**

**With folded rim**



#	Ø mm	↑ mm
162080	80	20
162100	100	20
162120	120	20
162140	140	20
162160	160	20
162180	180	20
162200	200	20
162220	220	20
162240	240	20
162260	260	20
162280	280	20
162300	300	20
162320	320	20
162340	340	20

**Ohne Borde**

**Without folded rim**



#	Ø mm	↑ mm
163075	75	40
163080	80	45
163120	120	45
163140	140	45
163160	160	45
163180	180	45
163200	200	45
163220	220	45
163240	240	45
163260	260	45
163280	280	45
163300	300	45

**Ohne Borde**

**Without folded rim**



#	Ø mm	↑ mm
164120	120	60
164140	140	60
164160	160	60
164180	180	60
164200	200	60
164220	220	60
164240	240	60
164260	260	60
164280	280	60
164300	300	60

DE	DESSERT- UND TORTENRINGE
EN	DESSERT AND TART RINGS
IT	ANELLI PER DOLCI E TORTE
ES	AROS PARA POSTRES Y TARTAS

Material: Aluminium  
 • Nahtgeschweißt

Made of aluminium  
 • Welded seam

#	Ø mm	↑ mm	↓ mm	
156753	75	30	1,0	
156754	75	40	1,5	
156077	80	20	1,0	
156083	80	40	2,0	
156853	85	30	1,0	
156078	90	20	1,0	
156953	95	30	1,0	
156079	100	20	1,0	
156161	150	45	2,0	
156165	160	50	2,0	
156166	160	60	2,0	
156185	180	50	2,0	
156186	180	60	2,0	
156187	180	70	2,0	
156205	200	50	2,0	
156206	200	60	2,0	
156207	200	70	2,0	
156208	200	80	2,0	
156225	220	50	2,0	
156226	220	60	2,0	
156227	220	70	2,0	
156245	240	50	2,0	
156246	240	60	2,0	
156247	240	70	2,0	
156265	260	50	2,0	
156266	260	60	2,0	
156267	260	70	2,0	
156268	260	80	2,0	
156284	280	40	2,0	
156285	280	50	2,0	
156286	280	60	2,0	
156287	280	70	2,0	
156288	280	80	2,0	
156327	320	70	2,0	
156387	380	70	2,0	
156465	460	50	3,0	



6

DE	FLORENTINERRING / DESSERTRINGE
EN	DESSERT RINGS
IT	ANELLI PER DOLCI
ES	AROS PARA POSTRES

Material: Schwarzblech  
 • Verschweißte Naht

Made of black steel  
 • Welded seam

#	Ø mm	↑ mm	↓ mm	
164400	80	20	1,0	
164401	90	20	1,0	
164402	100	20	1,0	





DE	TORTENRING-SET
EN	SET OF TART RINGS FOR CAKE STANDS
IT	SET DI ANELLI PER TORTE
ES	JUEGO DE AROS PARA TARTAS

Aus Aluminium

- Nahtgeschweißt
- Materialstärke 2 mm
- Für 3-, 4-, 5- und 7-teiligen Tortenständer

Made of aluminium

- Welded seam
- Thickness: 2 mm
- For cake stands with 3 / 4 / 5 / 7 floors

#	↑ mm	∅ mm	
156013	60	190 / 250 / 310	3-teilig / 3 pieces
156014	60	190 / 250 / 310 / 390	4-teilig / 4 pieces
156015	60	190 / 250 / 310 / 390 / 440	5-teilig / 5 pieces
156017	60	150 / 190 / 250 / 310 / 390 / 440 / 490	7-teilig / 7 pieces



DE	TORTENBLECH
EN	FLAN CASE
IT	BASE PER TORTA
ES	BASE DE LA TARTA

Material: Aluminium

Made of aluminium

#	→□← ∅ mm	↔ ∅ mm	↑ mm
156980	265	260	8
156981	285	280	8



DE	TORTENSCHNEIBEN
EN	CAKE PLATES
IT	DISCHI PER TORTE
ES	DISCOS PARA TARTAS

Material: Aluminium

- Mit Aufhängeloch

Made of aluminium

- With hanging hole

#	∅ mm	↑ mm
156241	240	1,0
156261	260	1,0
156281	280	1,0
156282	280	1,5
156301	300	1,0
156302	300	1,5
156321	320	1,0
156322	320	1,5



DE	TORTENSCHNEIBENSTÄNDER
EN	SUPPORT FOR CAKE PLATES
IT	SUPPORTO PER DISCHI PER TORTE
ES	SOPORTE PARA DISCOS DE TARTAS

- Weiße Kunststoffbeschichtung
- 2 seitliche Griffe

- White plastic coating
- Handles on both sides

#	↔ mm
157010	500 x 200 x 180

DE	TORTENRING / STOLLENRING
EN	TART RINGS
IT	ANELLI PER TORTE
ES	AROS PARA TARTAS

- Material: Aluminium  
 • Nahtgeschweißt  
 • Materialstärke: 2,0 mm

- Made of aluminium  
 • Welded seam  
 • Thickness: 2.0 mm

**Ovale Form – für Quarkstollen**

**Oval**

#	↗ mm	→ mm	↑ mm
155050	235	105	40
155051	180	105	50

**Herz**

**Heart**

#	∅ mm	↑ mm
155070	160	50
155071	180	50
155072	200	50
155073	220	50
155074	240	50

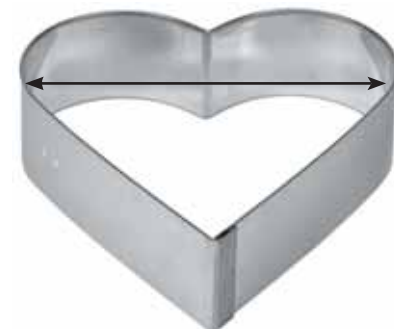

6

DE	BACKRAHMEN "HERZ"
EN	BAKING FRAMES "HEART"
IT	TELAJ PER TORTE, "CUORE", REGOLABILE
ES	AROS PARA TARTAS, CORAZÓN AJUSTABLE

- Material: Edelstahl  
 • Materialstärke: 0,5 – 1,0 mm  
 • Ausziehbar / verstellbar

- Made of stainless steel  
 • Thickness: 0.5 – 1.0 mm  
 • Extensible

#	↔ mm	↑ mm
199160	220 – 270	70
199161	290 – 380	70
199162	430 – 500	70

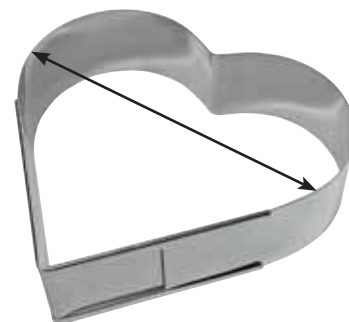

DE	TORTENRINGE RUND, VERSTELLBAR
EN	CAKE RINGS ROUND, ADJUSTABLE
IT	ANELLI PER TORTE ROTONDI, REGOLABILI
ES	AROS PARA TARTAS, AJUSTABLE

- Material: Edelstahl  
 • Materialstärke: 1,2 mm

- Made of stainless steel  
 • Thickness: 1.2 mm

#	↔ mm / mind.	↔ mm / max.	↑ mm
199986	180	300	50
199987	180	300	60
199988	300	500	60



DE	TORTENRING – HALBKREIS
EN	TART RING – SEMI-CIRCLE
IT	ANELLO PER TORTE – SEMICERCHIO
ES	ARO PARA TARTAS – SEMICÍRCULO

- Material: Edelstahl

- Made of stainless steel

#	↗ mm	→ mm	↑ mm
164900	300	150	45



Passende Tortenplatte auf Seite 180. / Matching cake plate on page 180.

DE	DESSERT- / TORTENRINGE
EN	DESSERT / TART RINGS
IT	ANELLI PER TORTE E DESSERT
ES	AROS PARA TARTAS

Material: Edelstahl

Made of stainless steel

#		↔ mm	↑ mm
155060	Achteck / octagon	Ø: 160	50
155100	Sechseck / hexagon	Ø: 160	50
155110	Sechseck / hexagon	Ø: 180	50
155120	Sechseck / hexagon	Ø: 200	50
155200	Herz / heart	Ø: 180	50
155210	Herz / heart	Ø: 200	50
155220	Herz / heart	Ø: 230	50
155300	Dreieck / triangle	L: 160	50
155310	Dreieck / triangle	L: 180	50
155320	Dreieck / triangle	L: 200	50



# 155060



# 155100 – 155120



# 155200 – 155220



# 155300 – 155320

#		↗ mm	↑ mm	⏊ mm
155330	Tropfen / tear-drop	160	50	1,2
155331	Tropfen / tear-drop	180	50	1,2
155332	Tropfen / tear-drop	200	50	1,2
155340	Dreieck, gewölbt / triangle, convex	160	50	1,2
155341	Dreieck, gewölbt / triangle, convex	180	50	1,2
155342	Dreieck, gewölbt / triangle, convex	200	50	1,2
155350	Viereck, gewölbt / square, convex	140	50	1,0
155351	Viereck, gewölbt / square, convex	160	50	1,0
155352	Viereck, gewölbt / square, convex	180	50	1,0



# 155330 – 155332



# 155340 – 155342



# 155350 – 155352

DE	SCHNITTEN-/BACKRAHMEN QUADRAT / RECHTECKIG
EN	TART RINGS SQUARE / RECTANGULAR
IT	TELAJ PER TORTE, QUADRATI / RETTANGOLARI
ES	AROS PARA TARTAS, CUADRADOS / RECTÁNGULARES

Material: Edelstahl

- Materialstärke: 1,5 mm

Made of stainless steel

- Thickness: 1.5 mm

#	↗ mm	→ mm	↑ mm
155361	100	100	50
155363	120	120	50
155365	140	140	50
155367	160	160	50
155369	180	180	50
155371	200	200	50
155373	220	220	50
155375	240	240	50
155377	260	260	50
155379	280	280	50
155357	300	300	50
155380	140	240	40
155381	140	240	50
155382	160	260	40
155383	160	260	50
155384	180	280	40
155385	180	280	50
155386	220	300	40
155387	220	300	50
155388	260	380	40
155389	260	380	50
155390	300	400	40
155391	300	400	50
155399	380	580	50



6

DE	BACKRAHMEN RECHTECKIG, VERSTELLBAR
EN	CAKE RINGS, RECTANGULAR, ADJUSTABLE
IT	TELAJ PER TORTE, RETTANGOLARI, REGOLABILI
ES	AROS PARA TARTAS, RECTÁNGULARES, AJUSTABLES

Material: Edelstahl

- Materialstärke: 1,2 mm

Made of stainless steel

- Thickness: 1.2 mm

#	↔ mm	↔ mm (max.)	↑ mm
155400	215 x 115	405 x 200	80
155410	430 x 290	840 x 560	50
155420	300 x 300	570 x 560	50
155430	216 x 310	405 x 605	50

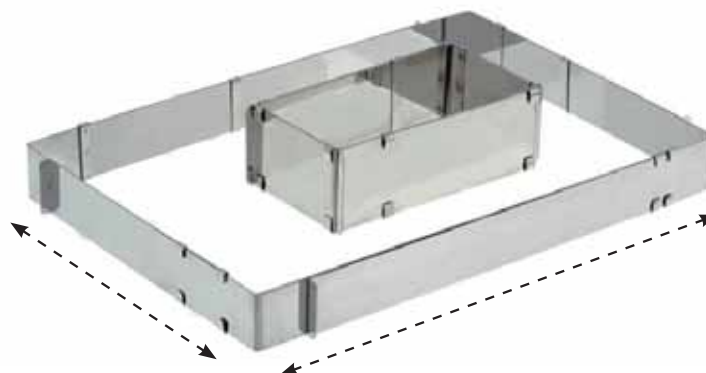

NICHT zum Backen geeignet!  
NOT for baking!



DE	DESSERTRING
EN	DESSERT RING
IT	ANELLO PER DOLCI
ES	ARO PARA POSTRES

**Material: PS, elfenbein**

**Made of PS, ivory**

#	Ø mm	↑ mm
200950	75	30



**Material: Reinaluminium**

**Made of pure aluminium**

- Nahtgeschweißt
- Extra stark

- Welded seam
- Extra strong

#	Ø mm	↑ mm	⊥ mm
156075	75	30	2,0
156076	75	40	2,0

**“MINI”**

Material: Edelstahl

- Materialstärke: 0,8 mm

**“MINI”**

Made of stainless steel

- Thickness: 0.8 mm

#		↔ mm	↑ mm
155450	Rund / round	Ø 70	45
155451	Oval / oval	L: 74 x B: 56	45
155452	Tropfen / drop	L: 77 x B: 54	45
155453	Dreieck / triangle	B: 68	45
155454	Herz / heart	H: 55 x B: 67	45
155455	Sechseck / hexagon	B: 54	45
155456	Quadrat / square	B: 54	45

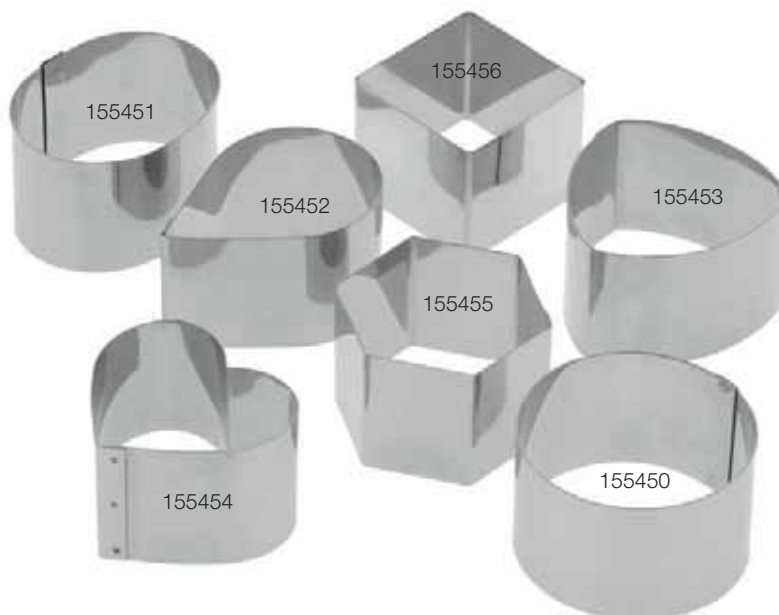

DE	TORTENGITTERSTANZE
EN	CAKE GRID CUTTER
IT	GRIGLIA PER CROSTATE
ES	REJILLA CORTANTE PARA PASTA FROLA

Material: PS, weiß

- Bestehend aus 2 Teilen
- Für Linzer Torten, Holländer Gebäck usw.

Made of PS, white

- 2 parts
- For "Linzer" cakes, Dutch pastries etc.

#	Ø
158006	300

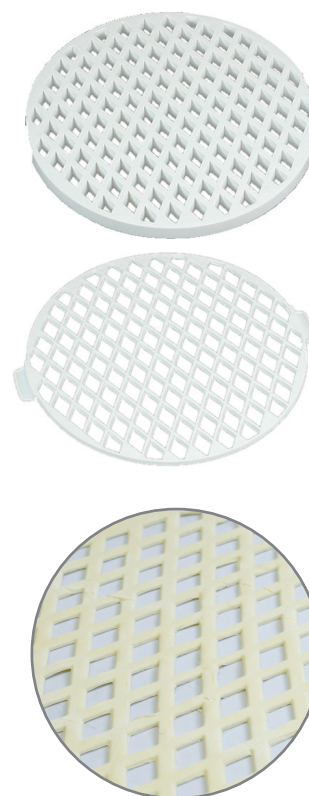

DE	TORTENBODENSÄGE
EN	TART / CAKE SAW
IT	LIRA PER PAN DI SPAGNA
ES	CORTADOR DE PASTELES

Material: Edelstahl

- Mit drei Sägeblättern
- Sägeblätter in der Höhe verstellbar

Made of stainless steel

- With three saw blades
- Saw blades adjustable in height

#	→□← mm	↔ mm	↑ mm
153500	460	430	235
153510	Ersatzblatt / Spare saw blade		

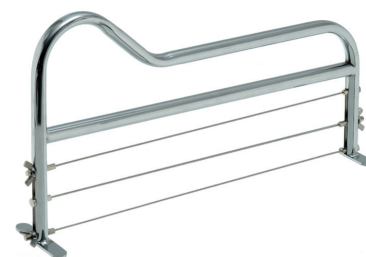

Material: Rahmen aus lackiertem Stahl

- 2 Sägeblätter aus Edelstahl
- Sägeblätter in der Höhe verstellbar

Frame made of lacquered steel

- 2 saw blades made of stainless steel
- Saw blades adjustable in height

#	→□← mm	↔ mm	↑ mm
153550	460	430	160
153351	Ersatzblatt / Spare saw blade		
153560	595	570	165
153352	Ersatzblatt / Spare saw blade		



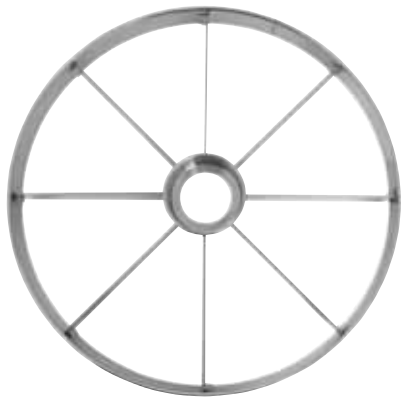

# 120108

DE	TORTENEINTEILER		
EN	CAKE DIVIDER	SST	+400 °C
IT	DIVISORIO PER TORTA		
ES	DIVISOR PARA TARTA		

- Ausführung: einseitig
- Type: one-sided

#	Teilung / Piece	Ø mm	↑ mm
120108	8	330	45
120110	10	330	45
120112	12	330	45
120114	14	330	45
120116	16	330	45
120118	18	330	45



# 120190

DE	TORTENEINTEILER		
EN	CAKE DIVIDER	SST	+400 °C
IT	DIVISORIO PER TORTA		
ES	DIVISOR PARA TARTA		

- Ausführung: beidseitig
- Mit 2 Seitengriffen
- Type: double-sided
- With 2 side handles

#	Teilung / Piece	Ø mm	↑ mm
120190	8/12	330	55
120191	10/12	330	55
120192	10/14	330	55
120193	10/16	330	55
120194	12/14	330	55
120195	12/16	330	55

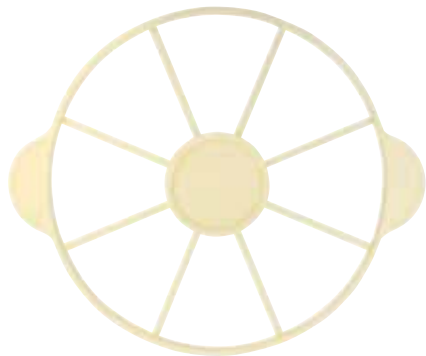

# 220108

DE	TORTENEINTEILER		
EN	CAKE DIVIDER	PP	-20 +80 °C
IT	DIVISORIO PER TORTA		
ES	DIVISOR PARA TARTA		

- Ausführung: einseitig
- Mit 2 Seitengriffen
- Type: one-sided
- With 2 side handles

#		Teilung / Piece	Ø mm	↑ mm
220108	○	8	265	20
220110	○	10	265	20
220112	○	12	265	20
220114	○	14	265	20
220116	○	16	265	20
220118	○	18	265	20
220119	○	20	265	20

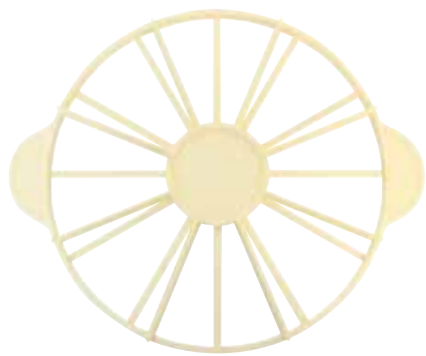

# 220128

DE	TORTENEINTEILER		
EN	CAKE DIVIDER	PP	-20 +80 °C
IT	DIVISORIO PER TORTA		
ES	DIVISOR PARA TARTA		

- Ausführung: beidseitig
- Mit 2 Seitengriffen
- Type: double-sided
- With 2 side handles

#		Teilung / Piece	Ø mm	↑ mm
220128	○	8/12	265	25
220120	○	12/16	265	25
220122	○	14/16	265	25
220124	○	12/18	265	25
220126	○	14/18	265	25

DE	SCHNITTENRAHMEN
EN	FRAME
IT	TELAIO DA TAGLIO
ES	MARCO PARA PORCIONES

Material: Aluminium

- Variabel verstellbarer Rahmen
- Teiler entnehmbar / versetzbar
- Doppelseitig verwendbar
- Für 28 Schnitten 60 x 60 mm oder 33 Schnitten 80 x 40 mm
- Für 70 Schnitten 80 x 40 mm oder 54 Schnitten 65 x 65 mm

Made of aluminium

- Variable adjustable frame
- Divider removable / relocatable
- Two-sided use
- For 28 pieces 60 x 60 mm or 33 pieces 80 x 40 mm
- For 70 pieces 80 x 40 mm or 54 pieces 65 x 65 mm

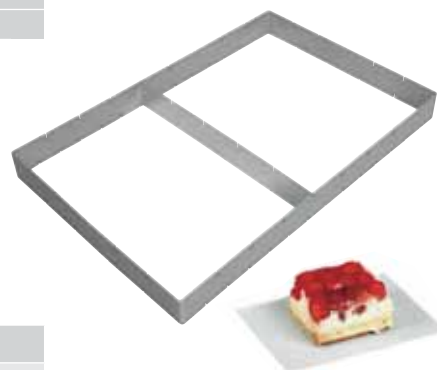

#	↗ mm	→ mm	↑ mm	
199590	440	240	50	
199591	560	370	50	

6

DE	BACKLINEALE
EN	DOUGH RULERS
IT	RIGHELLI PER PASTICCERIA
ES	REGLAS GRADUADAS PARA PASTERÍA

Material: Polystyrol, flexibel, weiß

- Mit Aufhängeöse
- 7 Einteilungen 8 cm
- 5 Einteilungen 12 cm

Made of polystyrene, flexible, white

- With suspension eye
- 7 divisions of 8 cm each
- 5 divisions of 12 cm each

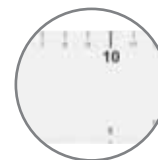

#	↗ mm	→ mm	↑ mm	
<input checked="" type="checkbox"/> 200900	640	50	2	

- 13 Einteilungen 8 cm
- 8 Einteilungen 12 cm

- 13 divisions of 8 cm each
- 8 divisions of 12 cm each

#	↗ mm	→ mm	↑ mm	
<input checked="" type="checkbox"/> 200915	980	50	2	

Material: Resopal, stabil, weiß

- Mit Aufhängeöse
- 7 Einteilungen 8 cm
- 5 Einteilungen 12 cm

Made of Formica, solid, white

- With suspension eye
- 7 divisions of 8 cm each
- 5 divisions of 12 cm each

#	↗ mm	→ mm	↑ mm	
<input checked="" type="checkbox"/> 200899	645	50	2	



DE	TORTENGITTER
EN	GRATES
IT	GRIGLIE
ES	REJILLAS

Material: Edelstahl

Made of stainless steel

#		Ø mm
156115	"Karo" mit Füßen / "square" pattern, with feet	320
156116	"Karo" mit Füßen / "square" pattern, with feet	360
156128	"Spirale" ohne Füße / "spiral" pattern, without feet	320
156129	"Spirale" ohne Füße / "spiral" pattern, without feet	360
156130	"Spirale" mit Füßen / "spiral" pattern, with feet	320
156131	"Spirale" mit Füßen / "spiral" pattern, with feet	360



# 156115 + 156116

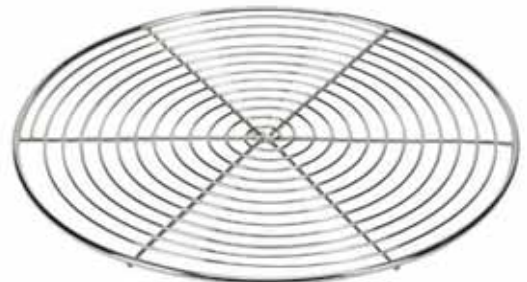

# 156128 + 156129



# 156130 + 156131

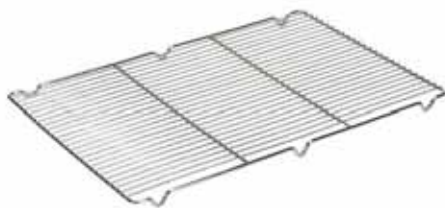

Material: Edelstahl

- Extra stabile Ausführung
- Mit 3 Traversen
- Mit Füßen

Made of stainless steel

- Very strong quality
- With 3 traverses
- With feet

#	↗ mm	→ mm
156124	590	390



© stock.adobe.com

DE	PRALINEN- / TRÜFFELGITTER
EN	CHOCOLATE / TRUFFLE GRATES
IT	GRIGLIE PER CIOCCOLATINI E TARTUFFI
ES	REJILLAS PARA PRALINÉS Y TRUFAS

Material: Edelstahl

- Design: „Karo“
- Mit Füßen
- Höhe: 28 mm

Made of stainless steel

- Design: “square” pattern
- With feet
- Height: 28 mm



#	↗ mm	→ mm	⊞ mm	⊥ mm
156125	440	315	10 x 10	1
156126	580	390	10 x 10	1

DE	GRILLROSTE
EN	GRIDS
IT	GRIGLIE
ES	REJILLAS

Material: Edelstahl

Made of stainless steel

#		↗ mm	→ mm	≡	∅ mm	Drähte ∅ mm / wire ∅ mm
156110		600	400	2	6	24 / 3
156111	<b>GN 1/1</b>	530	325	1	7	20 / 3
156112	<b>GN 2/3</b>	354	325	1	5	15 / 2
156113	<b>GN 2/1</b>	650	530	3	6	32 / 2

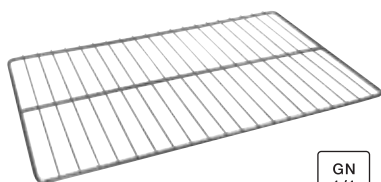
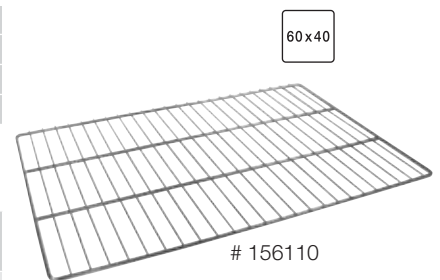

# 156111

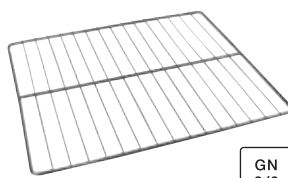

# 156112

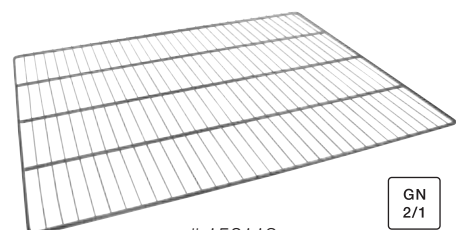

# 156113



DE	SCHILLERLOCKENFORMEN / HÖRNCHENBACKFORM – GERADE
EN	CREAM HORN MOULDS STRAIGHT
IT	CONI PIATTI PER CANNONCINI
ES	MOLDES PARA CONOS, PLANOS

Material: Edelstahl

Made of stainless steel

#	↗ mm	Ø mm	
198012	90	25	
198008	120	30	
198009	140	35	
198010	160	40	



DE	SCHILLERLOCKENFORMEN SCHRÄG
EN	CREAM HORN MOULDS OBLIQUE
IT	CONI OBLIQUI PER CANNONCINI
ES	MOLDES PARA CONOS, OBLICUOS

Material: Edelstahl

Made of stainless steel

#	↗ mm	Ø mm	
198013	120	30	
198014	140	35	
198015	160	40	



DE	CANNOLI
EN	CANNOLI
IT	STAMPI PER CANNOLI
ES	MOLDES PARA CANNOLI

Material: Edelstahl

Made of stainless steel

#	↗ mm	Ø mm	
198017	125	35	



DE	RAHM- UND CREMEROLLEN / CANNOLI BACKFORM
EN	CREAM ROLL MOULDS
IT	STAMPI PER CANNONCINI
ES	MOLDES PARA CANUTILLOS

Material: Edelstahl

Made of stainless steel

#	↗ mm	Ø mm	
198000	200	9	
198001	200	11	
198002	200	12,5	
198003	200	14	
198004	200	16	
198005	200	18	
198006	140	22	
198007	140	27	

DE	MARZIPAN-MODELLIERSET
EN	MARZIPAN MODELLING SET
IT	KIT PER MARZAPANE (15 PZ.)
ES	JUEGO DE UTENSILIOS PARA MAZAPÁN (15 UNIDADES)

Material: PP

- Das Set bestehend aus:  
2 Strukturbrettern, 1 Marzipanmesser,  
12 verschiedene Modellierstäbe

Made of PP

- Set consisting of 2 boards, 1 knife and  
12 modelling tools



#		
227200	Set 15-teilig / set 15 pieces	

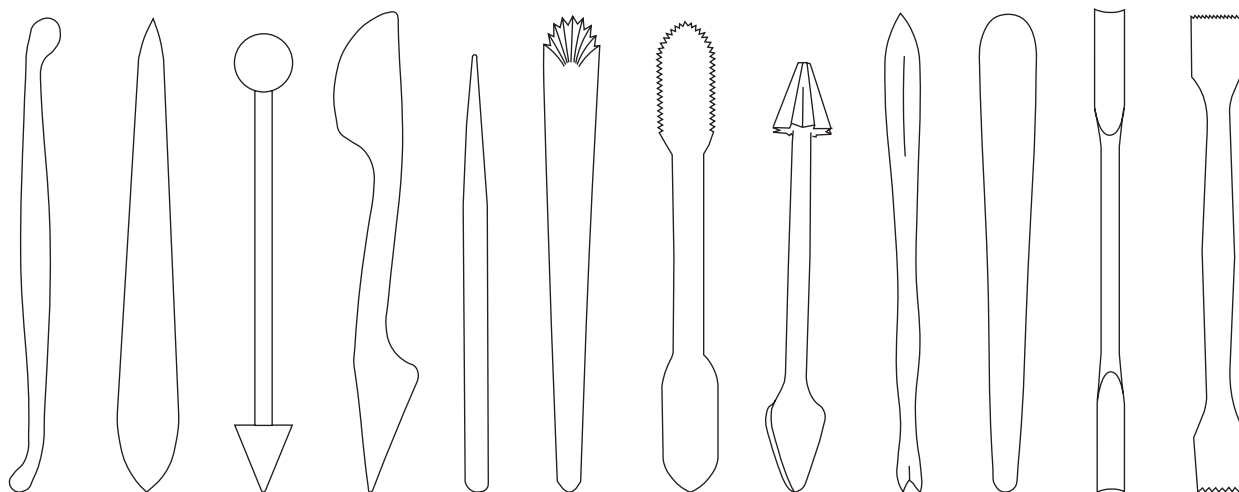

DE	GLÄTTER FÜR FONDANT
EN	CAKE POLISHER FOR SUGAR PASTE
IT	STENDIPASTA PER PASTA DI ZUCCHERO
ES	ESPATÚLA PARA FONDANT (PASTA DE AZÚCAR)

Material: Kunststoff, weiß

Made of plastic, white

#		↔ mm
166130		160 x 80



DE	MODELLIERSET
EN	MODELLING SET
IT	KIT DI UTENSILI PER MODELLARE (8 PZ.)
ES	JUEGO DE UTENSILIOS PARA MODELAR (8 UNIDADES)

Material: Kunststoff

- Farbe: rot / weiß

Made of plastic

- Color: red / white

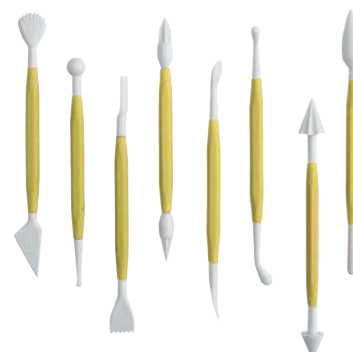

#		↗ mm
166140		165
	Set 8-teilig / set 8 pieces	



# 181014

DE	WASSER-SPRÜHPISTOLE / GEBÄCKSPRÜHER
EN	WATER SPRAY GUN
IT	PISTOLA VAPORIZZATRICE
ES	PISTOLA VAPORIZADORA

Griff: PA, schwarz  
 Schlauch ausziehbar bis 300 – 400 cm,  
 Anschlüsse Edelstahl, Messing, vernickelt

- Teiglinge, Brote und Brötchen können waagrecht und nebfrei besprüht werden
- Raum- und zeitsparend
- Hygienisch, ersetzt Brotstreicher

Handle: PA, black  
 extensible hose up to 300 – 400 cm,  
 connections Made of stainless steel, brass,  
 nickel-plated

- For spraying steam on dough and bread
- Usable horizontally
- Space and time saving, hygienic

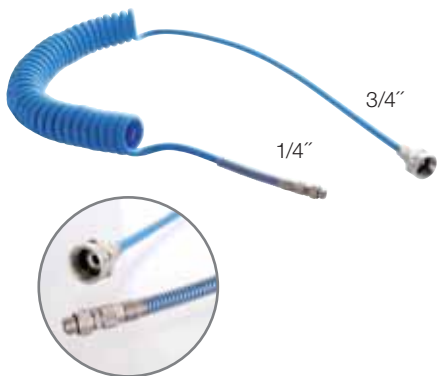

1/4"



# 181100



# 181160



# 181170

#		l (cm)
181014	Wasser-Sprühpistole gerade / spray gun, straight sprayer pipe	22
181100	Wasser-Sprühpistole 30° abgewinkelt / spray gun, angular sprayer pipe 30°	22
181160	Wasser-Sprühpistole 30° abgewinkelt / spray gun, angular sprayer pipe 30°	60
181170	Wasser-Sprühpistole 30° abgewinkelt / spray gun, angular sprayer pipe 30°	100
181200	Schlauch – blau / hose – blue	



# 182005

DE	WASSER-SPRÜHPISTOLE / GEBÄCKSPRÜHER	
EN	WATER SPRAY GUN	
IT	PISTOLA VAPORIZZATRICE	
ES	PISTOLA VAPORIZADORA	

Griff: PA, schwarz  
 Schlauch ausziehbar bis 300 – 400 cm,  
 alle Bauteile aus Edelstahl

- Teiglinge, Brote und Brötchen können waagrecht und nebfrei besprüht werden
- Raum- und zeitsparend
- Hygienisch, ersetzt Brotstreicher
- **100% Lebensmittelecht**

Handle: PA, black  
 extensible hose up to 300 – 400 cm,  
 all components Made of stainless steel

- For spraying steam on dough and bread
- Usable horizontally
- Space and time saving, hygienic
- **100% food safe**



# 182000

#		
182005	Wasser-Sprühpistole gerade – Standard Düse 35 – 40 Liter / spray gun, straight sprayer pipe – Nozzle 35 – 40 l	
182000	Wasser-Sprühpistole 30° abgewinkelt – Standard Düse 35 – 40 Liter / spray gun, angular sprayer pipe 30° – Nozzle 35 – 40 l	
182010	Schlauch – schwarz / hose – black	
182020	Ersatzteil-Set / Spare parts set	
182030	Reduzierstück / adapter	
182040	Ersatzdüse inkl. Dichtungsring – Fördermenge ca. 35 bis 40 l/h / Spare nozzle incl. sealing ring – flow rate approx 35 to 40 l/h	
182045	Ersatzdüse inkl. Dichtungsring – Fördermenge ca. 6 bis 8 l/h / Spare nozzle incl. sealing ring – flow rate approx 6 to 8 l/h	



# 182010



# 182020



# 182030



# 182040



# 182045



DE	HANDENTSTEINER
EN	PLUM STONING DEVICE
IT	SNOCCIOLATORE PER PRUGNE
ES	DESCORAZONADOR DE CIRUELAS

Material: Aluminiumguss

- Für Pflaumen und Zwetschgen
- Mit Rechts- und Linkshandgriff
- Obstsäurebeständiges Messer

Made of cast aluminium

- For plums
- Usable for right and left-handed users
- With stone outlet and fruit ejector
- Acid resistant knife

#		
151300	Handentsteiner inkl. 6-teiliges Messer mit Auswerfer	
151301	Ersatzmesser 6-teilig/replacement knife (6 pcs.)	



DE	APFELSCHÄLMASCHINE
EN	APPLE PEELING MACHINE
IT	PELA E AFFETTA MELE
ES	PELADORA DE MANZANAS



Gehäuse aus Aluminiumguß, weiß lackiert

- Alle Metallteile aus rostfreiem Stahl
- Für Bäckereien, Konditoreien, Küchen, gewerbliche Zwecke
- Maschine schält den frischen Apfel innerhalb von 15 Sekunden und sticht das Kernhaus aus

Housing made of cast aluminium, white

- All metal parts made of stainless steel
- For bakeries, confectioneries, kitchens, commercial use
- Machine peels the fresh apple within 15 seconds and removes the the core out



#				
150000	60 W	220 V	130 x 410 x 195	5,6



DE	THERMOMETER / EINSTICHTHERMOMETER
EN	THERMOMETER
IT	TERMOMETRO
ES	TERMÓMETRO



- Temperaturfühler 1,5 mm dünn
  - Fühlt die Temperatur im Produkt und nicht in der Umgebung
  - Reaktionszeit ca. 2–4 Sekunden
  - Genauigkeit: 0,1°C
  - 80 cm Kabel
  - Gehäuse mit eingebautem Magnet – haftet an allen ferromagnetischen Oberflächen
  - Kostenlose APP (IOS- und Android Gerät) via Bluetooth mit dem Thermometer verknüpfbar
  - Für professionelle Wareneingangskontrolle
  - Datum, Uhrzeit und eigenen Notizen können mit dem zugeordneten Foto gespeichert und versendet werden
  - Batterien sind nicht im Lieferumfang enthalten
- Temperature sensor 1.5 mm thin
  - The temperature is measured inside the product and not in the environment
  - Reaction time approx. 2–4 seconds
  - Accuracy: 0.1 °C
  - Cable length 80 cm
  - Housing with built-in magnet – adheres to all ferromagnetic surfaces
  - Free app (IOS and Android device) can be connected via Bluetooth with the thermometer
  - For professional incoming goods inspection
  - Date, time and own notes can be saved and sent with the assigned photo
  - Batteries not included

#	°C
160050	- 200 / + 400

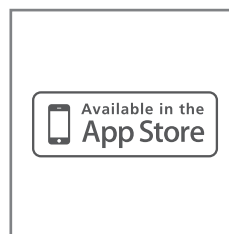
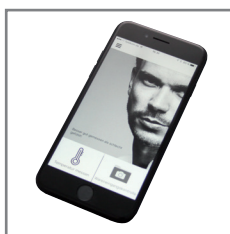

DE	INFRAROT-THERMOMETER
EN	INFRARED THERMOMETERS
IT	TERMOMETRI
ES	TERMÓMETROS

Für berührungsloses Messen der Oberflächentemperatur.

For non-contact measuring of surface temperature.

- Großes beleuchtetes Display
- Messdauer 0,5 Sekunden
- Mit Laservisier
- Batterien sind nicht im Lieferumfang enthalten

- Large backlight display
- Measuring time 0.5 seconds
- With laser-sighting
- Batteries not included



# 160014

#	°C	↔ mm
160014	-35 / + 365	166 x 34 x 64

- Beleuchtetes Display,
- Messdauer 1,0 Sekunden
- Inclusive Tasche
- Batterien sind nicht im Lieferumfang enthalten

- Backlight display
- Measuring time 1.0 seconds
- Bag included
- Batteries not included



# 160019

#	°C	↔ mm
160019	-33 / + 500	175 x 39 x 79

- Großes beleuchtetes Display
- Messdauer 0,8 Sekunden
- Mit Laservisier
- Batterien sind nicht im Lieferumfang enthalten

- Large backlight display
- Measuring time 0.8 seconds
- With laser-sighting
- Batteries not included



#	°C	↔ mm
<input checked="" type="checkbox"/> 160100	-50 / + 550	150 x 40 x 105

- Infrarot-Thermometer mit Einsteckfühler
- Zum Messen der Oberflächen- und Kerntemperatur
  - Max.-Min.-Funktion
  - Messbereich Einsteckfühler -40°C / +280°C
  - Genauigkeit +/- 2°C im Bereich -40°C / +20°C, +/-1°C im Bereich +20°C / +100°C, sonst +/-1%, Auflösung 0,1°C, D:S = 4:1
  - Batterien sind nicht im Lieferumfang enthalten

- Infrared thermometer with plug-in sensor
- For measuring the surface and core temperature
  - Max.-min. function
  - Measuring range penetration probe -40°C/+280°C
  - Accuracy +/- 2°C in the range -40°C / +20°C, +/-1°C in the range +20°C / +100°C, otherwise +/-1%, resolution 0.1°C, D:S = 4:1
  - Batteries not included



#	°C	↔ mm
<input checked="" type="checkbox"/> 160051	-40 / + 280	140 x 380 x 24

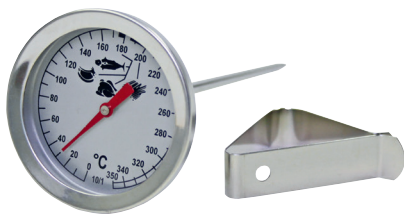

DE	THERMOMETER
EN	THERMOMETERS
IT	TERMOMETRI
ES	TERMÓMETROS

Material: Edelstahl / Made of stainless steel

#	°C	für/for	
<input checked="" type="checkbox"/> 160005	0 / +350	Fleisch / meat	

Verchromter Draht / Chromed wires

#	°C	für/for	↗ mm	
160001	-10 / +110	Milch / milk	300	
160002	+80 / +180	Zucker / sugar	300	
160003	+80 / +220	Fett / fat	300	

**i** Füllstoff: gefärbter Weingeist. / Filling material: colored alcohol.

- Mit Klipp / • Pen thermometers

#	°C	↗ mm	
160004	-20 / +50	140	

**i** Füllstoff: gefärbter Weingeist. / Filling material: colored alcohol.

- Glaseinsatz / • Glass insert
- Gehäuse aus Kunststoff / • Plastic housing

#	°C	für/for	↗ mm	
160012	0 / +110	Milch / milk	280	

**i** Füllstoff: eingefärbtes Petroleum. / Filling material: colored petroleum.

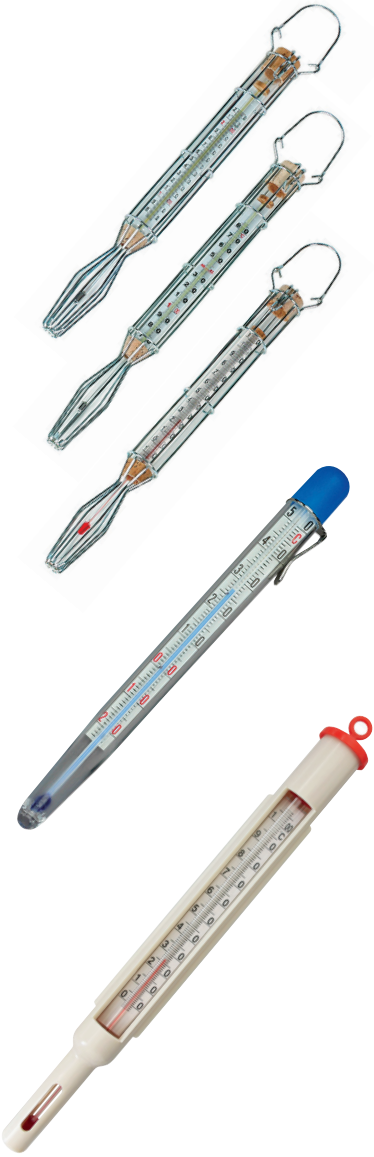

DE	STIELSCHABER MIT THERMOMETER
EN	SPATULA WITH THERMOMETER
IT	SPATOLE CON TERMOMETRO
ES	ESPÁTULA CON TERMOMETRO

- Hitzebeständiges Silikon / • Heat-resistant silicone
- Auflösung: 0,1°C / • Resolution: 0.1° C
- Genauigkeit: +/- 1°C (0°C / + 100°C), sonst +/- 1% / • Accuracy: +/- 1°C (0°C / + 100°C), otherwise +/- 1%
- Fühlerlänge: 235 mm / • Probe length: 235 mm
- Batterien sind nicht im Lieferumfang enthalten / • Batteries not included

#	°C	↔ mm	
<input checked="" type="checkbox"/> 160015	-50 / +300	320 x 65	



DE	THERMOMETER
EN	THERMOMETERS
IT	TERMOMETRI
ES	TERMÓMETROS



Kühlthermometer

- Kunststoffgehäuse, mit Halter und Befestigungsmaterial
- Abweichung +/- 0,5 °C

Freezer / fridge thermometer

- Plastic housing, support and fixing material
- Difference +/- 0,5 °C

#	°C	↗ mm
160028	- 30 / +20	265

**i** Füllstoff: gefärbter Weingeist. / Filling material: colored alcohol.  
 Werkprüfschein liegt vor. / Manufacturer test certificate available.

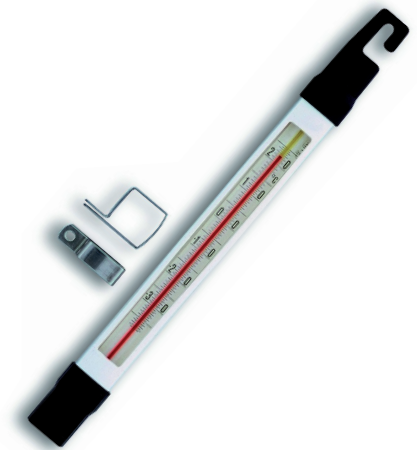

Kühlthermometer

- Kunststoffgehäuse
- Drehbar

Freezer / fridge thermometer

- Plastic housing
- Rotating

#	°C	↗ mm
160026	- 50 / +50	215 mm

**i** Füllstoff: gefärbter Weingeist. / Filling material: colored alcohol.



Kühlthermometer

- Kunststoffgehäuse mit Halter

Freezer / fridge thermometer

- Plastic housing and support

#	°C	↗ mm / Ø mm
160034	- 46 / +30	215
160035	- 30 / +50	Ø: 52
160036	- 50 / +50	Ø: 70

# 160035

# 160034



# 160036

DE	REFRAKTOMETER
EN	REFRACTOMETER
IT	RIFRATTOMETRO
ES	REFRACTÓMETRO

Hand-Refraktometer zur Messung des Brix-Wertes von Zucker, Glasur, Sorbets, Konfitüren, Eis und Gelees.

- Spritzwassergeschützt
- Inkl. Aufbewahrungsbox

Hand-held refractometer for measuring the Brix value of sugar, icing, sorbets, jams, ice cream and jellies.

- Splash proof
- Including storage box

#	
161020	0 – 50 % Brix
161030	0 – 90 % Brix



DE	DIGITALER EINSTICHTHERMOMETER
EN	DIGITAL PROBE THERMOMETER
IT	TERMOMETRO CON SONDA
ES	TERMÓMETRO CON SONDA

Für Temperaturmessungen in Flüssigkeiten, pulverigen und plastischen Stoffen.

For temperature measurements of liquid, powdered and plastic materials.

- Mit extralangem Fühler (125 mm)
- Wasserdicht
- Umschaltbar °C/°F
- Inklusive Schutzhülse
- Batterien sind nicht im Lieferumfang enthalten

- With extra long probe, (125 mm)
- Waterproof
- Switchable °C/°F
- Including protection case
- Batteries not included

#	°C
<input checked="" type="checkbox"/> 160006	- 40 / + 200

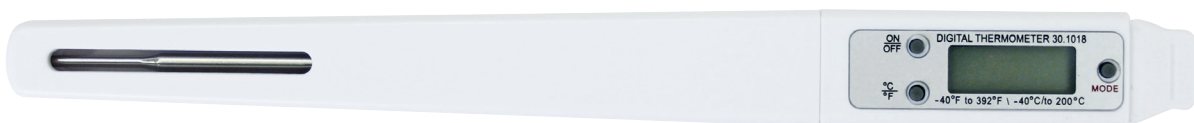

- Temperaturmessung gemäß HACCP
- Messung berührungslos mit Einstichfühler
- Wasserdicht
- Batterien sind nicht im Lieferumfang enthalten

- Temperature measurement according to HACCP
- Non-contact measurement with insertion probe
- Waterproof
- Batteries not included

#	°C	↔ mm
160029	- 40 / + 250	60



- Hold / Test-Funktion
- Genauigkeit +/-1°C
- Auflösung 0,1°C
- Fühlerlänge: 140 mm
- Batterien sind nicht im Lieferumfang enthalten

- Hold / Test Function,
- Accuracy +/-1°C
- Resolution: 0.1°C
- Probe length: 140 mm
- Batteries not included

#	°C	↔ mm
<input checked="" type="checkbox"/> 160052	- 50 / + 300	240



DE	DIGITALER EINSTICHTHERMOMETER
EN	DIGITAL PROBE THERMOMETER
IT	TERMOMETRO CON SONDA
ES	TERMÓMETRO CON SONDA

- |  |   |
|--|---|
| <ul style="list-style-type: none"> <li>• Hold / Test-Funktion</li> <li>• Temperaturalarm</li> <li>• Max.-Min.-Funktion</li> <li>• Genauigkeit +/-1°C</li> <li>• Auflösung 0,1°C</li> <li>• Fühlerlänge: 100 mm,</li> <li>• Kabellänge: ca.1 Meter</li> <li>• Batterien sind nicht im Lieferumfang enthalten</li> </ul> | <ul style="list-style-type: none"> <li>• Hold / Test Function</li> <li>• Temperature alarm</li> <li>• Max. min. function</li> <li>• Accuracy +/-1°C</li> <li>• Resolution: 0.1°C</li> <li>• Probe length: 100 mm,</li> <li>• Cable length: approx. 1 meter</li> <li>• Batteries not included</li> </ul> |
|--|---|

#	°C	↔ mm
<input checked="" type="checkbox"/> 160056	-50 / + 300	120 x 60



- |   |   |
|---|---|
| <ul style="list-style-type: none"> <li>• Temperaturalarm, Timer</li> <li>• Standgerät und mit Magnet</li> <li>• Fühlerlänge: 140 mm,</li> <li>• Kabellänge: ca.1 Meter</li> <li>• Batterien sind nicht im Lieferumfang enthalten</li> </ul> | <ul style="list-style-type: none"> <li>• Temperature alarm, timer for setting</li> <li>• Tabletop and magnet-mountable</li> <li>• Probe length: 140 mm,</li> <li>• Cable length: approx. 1 meter</li> <li>• Batteries not included</li> </ul> |
|---|---|

#	°C	↔ mm
160054	- 26 / + 250	65 x 70



7

DE	ELEKTRONISCHER TIMER
EN	ELECTRONIC TIMER
IT	TIMER PROGRAMMABILE ELETTRONICO
ES	TEMPORIZADOR ELECTRÓNICO

- |  |  |
|--|--|
| <p>Count-Down-Timer mit Stoppuhr</p> <ul style="list-style-type: none"> <li>• 99 Min., 59 Sek.</li> <li>• Magnethalterung</li> <li>• Batterien sind nicht im Lieferumfang enthalten</li> </ul> | <p>Countdown timer with stopwatch</p> <ul style="list-style-type: none"> <li>• 99 minutes, 59 seconds.</li> <li>• Magnetic holder</li> <li>• Batteries not included</li> </ul> |
|--|--|

#	↔ mm
<input checked="" type="checkbox"/> 160018	70 x 53 x 8





DE	BACKHANDSCHUHE "PREMIUM"	
EN	BAKING MITTENS "PREMIUM"	
IT	GUANTI DA FORNO "PREMIUM"	
ES	MANOPLAS PARA HORNO "PREMIUM"	

- Baumwolle, Farbe natur
- Innenhand und Daumen verstärkt
- Hitzebeständig bis + 250 °C / max. 15 sec.
- Waschmaschinenfest bis + 40 °C
- Cotton, natural color
- Reinforced palm and thumb
- Heat resistant up to + 250 °C / max. 15 sec.
- Machine-washable up to + 40 °C

#	↗ mm	→ mm	
<input checked="" type="checkbox"/> 310001	270	150	



**Mit kurzen Stulpen**

**Short cuffs**

#	↗ mm	→ mm	
<input checked="" type="checkbox"/> 310002	340	160	

**„LADY“ – schmale Ausführung**

**„LADY“ – slim version**

#	↗ mm	→ mm	
<input checked="" type="checkbox"/> 310103	340	140	



**Mit langen Stulpen**

**Long cuffs**

#	↗ mm	→ mm	
<input checked="" type="checkbox"/> 310003	400	150	

DE	BACKHANDSCHUHE "STANDARD"	EN 407
EN	BAKING MITTENS "STANDARD"	
IT	GUANTI DA FORNO "STANDARD"	
ES	GUANTES MANOPLAS PARA HORNO "STANDARD"	X2XXXX

- |   |   |
|---|---|
| <ul style="list-style-type: none"> <li>• Baumwolle, Farbe natur</li> <li>• Ganzflächig verstärkt</li> <li>• Hitzebeständig bis +250°C / max. 15 sec.</li> <li>• Waschmaschinenfest bis +40°C</li> </ul> | <ul style="list-style-type: none"> <li>• Cotton, natural color</li> <li>• Fully reinforced</li> <li>• Heat resistant up to +250°C / max. 15 sec.</li> <li>• Machine-washable up to +40°C</li> </ul> |
|---|---|

#	↗ mm	→ mm	
<input checked="" type="checkbox"/> 310019	325	150	



DE	BACKHANDSCHUHE SILIKON	EN 407
EN	BAKING MITTENS SILICONE	
IT	GUANTI DA FORNO IN SILICONE	
ES	GUANTES MANOPLAS DE SILICONA PARA HORNO 3 DEDOS	X2XXXX

- |  |  |
|--|--|
| <ul style="list-style-type: none"> <li>• 100% Silikon</li> <li>• Hitzebeständig bis +250°C / max. 15 sec.</li> <li>• Flexibles Material</li> <li>• Wasserdicht, spülmaschinengeeignet</li> <li>• Hygienisch, sterilisierbar</li> </ul> | <ul style="list-style-type: none"> <li>• 100% silicone</li> <li>• Heat resistant up to +250°C / max. 15 sec.</li> <li>• Flexible material</li> <li>• Waterproof, dishwasher safe</li> <li>• Hygienic, can be sterilised</li> </ul> |
|--|--|

#	↗ mm	→ mm	
310031	285	160	
310032	385	180	



DE	GASTROHANDSCHUH „SILIKON“	EN 407
EN	GASTRO MITTENS „SILICONE“	
IT	GUANTO GASTRO „SILICONE“	
ES	MANOPLAS GASTRO „SILICONA“	X2XXXX

- |   |  |
|---|--|
| <ul style="list-style-type: none"> <li>• Material: Silikon mit Baumwollfutter</li> <li>• Für Rechts- und Linkshänder</li> <li>• Zwischen Daumen und Zeigefinger verstärkt</li> <li>• Wasserdicht</li> <li>• Flexibles Material</li> <li>• Hitzebeständig bis +250°C / max. 15 sec.</li> <li>• Handreinigung max. 30 – 40°C</li> </ul> | <ul style="list-style-type: none"> <li>• Made of silicone with cotton lining</li> <li>• For right- and left-handers</li> <li>• Reinforced between thumb and index finger</li> <li>• Waterproof</li> <li>• Flexible material</li> <li>• Heat resistant up to +250°C / max. 15 sec.</li> <li>• Manual cleaning max. 30 – 40°C</li> </ul> |
|---|--|

#	↗ mm	→ mm	
<input checked="" type="checkbox"/> 310099	380	150	



DE	BACKHANDSCHUH NEOPREN	EN 407
EN	BAKING MITTENS NEOPRENE	
IT	GUANTO DA FORNO IN NEOPRENE	
ES	MANOPLAS NEOPRENE PARA HORNO	X2XXXX

- |  |  |
|--|--|
| <ul style="list-style-type: none"> <li>• Material: Neopren, schwarz</li> <li>• Für Rechts- und Linkshänder</li> <li>• Hitzebeständig bis +250°C / max. 15 sec.</li> <li>• Rutschfest</li> <li>• Wasserabstoßendes und fleckenresistentes Material</li> <li>• Handreinigung max. 30 – 40°C</li> </ul> | <ul style="list-style-type: none"> <li>• Made of neoprene, black</li> <li>• For right- and left-handers</li> <li>• Heat resistant up to +250°C / max. 15 sec.</li> <li>• Non-slip</li> <li>• Water repellent and stain resistant material</li> <li>• Manual cleaning max. 30 – 40°C</li> </ul> |
|--|--|

#	↗ mm	→ mm	
310085	350	145	





DE	BACKHANDSCHUHE LEDER	
EN	BAKING MITTENS LEATHER	
IT	GUANTI DA FORNO IN PELLE	
ES	MANOPLAS PARA HORNO EN CUERO	

- Leder, gefüttert
- Hitzebeständig bis +250°C / max. 15 sec.
- Nicht waschmaschinenfest
- Leather, inner lining
- Heat resistant up to +250°C / max. 15 sec.
- Not machine-washable

**Leder mit Stulpen**

**Leather with cuffs**

#	↗ mm	→ mm	
<input checked="" type="checkbox"/> 310111	450	140	

**„LADY” – schmale Ausführung**

**“LADY” – slim version**

#	↗ mm	→ mm	
<input checked="" type="checkbox"/> 310115	390	130	

- Leder, gefüttert
- Hitzebeständig bis +100°C / max. 15 sec.
- Nicht waschmaschinenfest
- Leather, inner lining
- Heat resistant up to +100°C / max. 15 sec.
- Not machine-washable

**“5 Finger” mit Stulpen**

**“5 fingers” with cuffs**

#	↗ mm	→ mm	
<input checked="" type="checkbox"/> 310023	450	140	

- Leder, gefüttert
- Hitzebeständig bis +100°C / max. 15 sec.
- Nicht waschmaschinenfest
- Leather, inner lining
- Heat resistant up to +100°C / max. 15 sec.
- Not machine-washable

**“3 Finger” mit Stulpen, speziell für das Entnehmen von kleinen Blechen**

**“3 fingers” with cuffs, especially for taking small tins**

#	↗ mm	→ mm	
<input checked="" type="checkbox"/> 310024	340	150	

EN 407



XXXXXX

O: Handschuhe erfüllen nicht die Mindestleistungsstufe  
 X: steht für Prüfung nicht durchgeführt

O: Gloves do not meet the minimum performance level  
 X: stands for test not performed

Leistungstufe	Performance level	1	2	3	4
Brennverhalten (Sek.)	Burning behaviour (sec.)	≤ 20	≤ 10	≤ 3	≤ 2
Kontaktwärme (°C / Sek.)	Contact heat (°C / sec.)	100°C ≥ 15	250°C ≥ 15	350°C ≥ 15	500°C ≥ 15
Konvektive Wärme (Sek.)	Convective heat (sec.)	≥ 4	≥ 7	≥ 10	≥ 18
Strahlungswärme (Sek.)	Radiant heat (sec.)	≥ 5	≥ 30	≥ 90	≥ 150
Kleine Spritzer geschmolzenen Metalls (Anzahl)	Small splashes of molten metal (number)	≥ 5	≥ 15	≥ 25	≥ 35
Große Mengen flüssiges Metall (Gramm)	Large quantities of liquid metal (grams)	20	60	100	150

DE	BACKHANDSCHUHE LEDER
EN	BAKING MITTENS LEATHER
IT	GUANTI DA FORNO IN PELLE
ES	MANOPLAS PARA HORNO EN CUERO

- Leder, gefüttert
- Hitzebeständig bis + 100°C / max. 15 sec.
- Nicht waschmaschinenfest
- Leather, inner lining
- Heat resistant up to + 100°C / max. 15 sec.
- Not machine-washable

**Leder mit Stulpen**

**Leather with cuffs**

#	↗ mm	→ mm
<input checked="" type="checkbox"/> 310090*	400	140



DE	BLECHANFASSER
EN	OVEN CLOTH
IT	PRESINA DA FORNO
ES	AGARRADOR PARA HORNO

- Baumwolle gesäumt
- Farbe natur
- Mit Griffflasche
- Hitzebeständig bis + 150°C
- Waschmaschinenfest bis + 40°C
- Cotton, reversible
- Natural color
- With grip tab
- Heat resistant up to + 150°C
- Machine-washable up to + 40°C

#	↗ mm	→ mm
<input checked="" type="checkbox"/> 310004	290	240

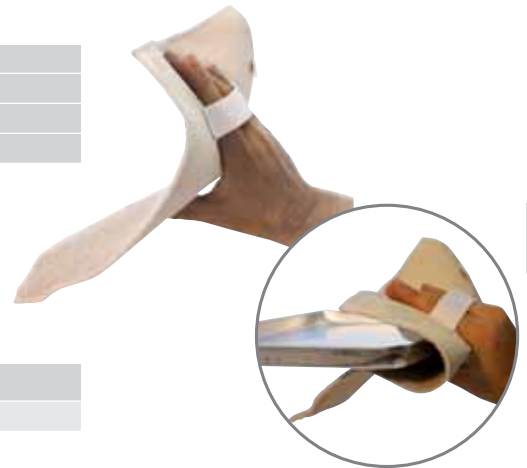

8

- Jute
- Farbe: natur
- Jute fibre mitten
- Natural color

#	↗ mm	→ mm
<input checked="" type="checkbox"/> 310009	250	200



DE	BAUMWOLLHANDSCHUHE "5 FINGER"
EN	GLOVES "5 FINGERS" – MADE OF COTTON
IT	GUANTI IN COTONE "5 DITA"
ES	GUANTES DE ALGODÓN "5 DEDOS"

- 100 % Baumwolle, weiß
- Pure cotton, white

#	↗ mm	→ mm
<input checked="" type="checkbox"/> 310027	240	100





DE	ZIP-HYGIENE-HANDSCHUH
EN	HYGIENE GLOVES
IT	GUANTI IGIENICI
ES	HIGIÉNICOS

Dieser Handschuh bietet vollständige Keimfreiheit beim Umgang mit Lebensmitteln. Insbesondere in Bäckereien oder der Gastronomie ist dieses Produkt eine schnelle und unkomplizierte Hilfe ohne ständig die Hände reinigen zu müssen. Durch die Benutzung wird eine direkte Berührung mit dem Lebensmittel verhindert. Die Anwendung beim Ein- und Ausschlüpfen ist durch das Verbindungselement mit einem automatischen Auf- und Abwickeln einer Zugschnur einfach und praktisch!

These gloves offer complete sterility while food is being handled. Especially in bakeries or in the food service trade they are a fast and easygoing help. It is not necessary to permanently wash the hands. By using these gloves a direct food contact is being prevented. The application of removing and inserting the hands is made simple and practical thru the use of a connecting element which automatically reels – and unreels the pull cord connected to the gloves.

#	Größe/size		
391530	G-50		50
391550	G-50/1	mit 1 Clip / with 1 clip	50 + 1
391535		Ersatzclip / replacement clip	1

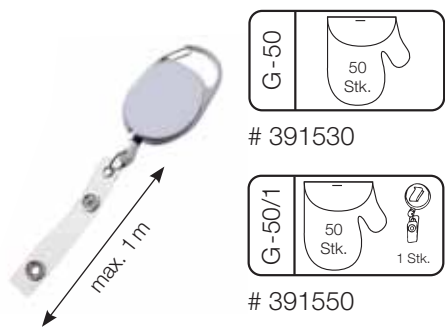

DE	ARBEITSSCHÜRZEN
EN	APRONS
IT	GREMBIULI
ES	DELANTALES

Material: beschichtete Baumwolle

- Reißfest und sehr stabil
- Gesäumt
- Hitzebeständig
- Einfach zu reinigen

Coated cotton

- Tear resistant
- Seamed
- Heat resistant
- Easy to clean

#	↔ mm	
120550	500 x 950	
120551	700 x 950	
120553	1000 x 950	mit Brustlatz / with bib
120554	1100 x 950	mit Brustlatz / with bib
120555	1200 x 1000	mit Brustlatz / with bib
120556	1300 x 1000	mit Brustlatz / with bib



Material: Baumwolle, weiß

- Gesäumt

Made of cotton, white

- Seamed

#	↔ mm
120557	450 x 800

DE	PAPIERMÜTZE "SCHIFFCHEN"
EN	LOW FORAGE HAT
IT	BUSTINA IN CARTA
ES	GORRO DE PAPEL "BARCO"

- Weiß, neutral
- Mit gelochtem Oberteil
- Verstellbar
- White, non-printed
- Perforated top
- Adjustable

#	↑ mm	
120100	85	1000



DE	KOCHMÜTZE "STANDARD"
EN	PLEATED CHEF'S HAT "STANDARD"
IT	CAPELLO DA CUOCO "STANDARD"
ES	GORRO COCINERO "STANDARD"

- Weiß, neutral
- Mit gelochtem Oberteil
- Verstellbar
- White, non-printed
- Perforated top
- Adjustable

#	↑ mm	
120200	216	50



8

DE	KOCHMÜTZEN "PREMIUM"
EN	PLEATED CHEF'S HAT "PREMIUM"
IT	CAPELLO DA CUOCO "PREMIUM"
ES	GORRO COCINERO "PREMIUM"

- Weiß, neutral
- Mit Schweißband
- Verstellbar
- White, non-printed
- With sweatband
- Adjustable

#	↑ mm	
120450	209	50



DE	KOCHMÜTZEN "MAITRE CHEF"
EN	PLEATED CHEF'S HAT "MAITRE CHEF"
IT	CAPELLO DA CUOCO "MAITRE CHEF"
ES	GORRO COCINERO "MAITRE CHEF"

- Weiß, neutral
- Plissiert
- Mit Schweißband
- Verstellbar
- White, non-printed
- Pleated
- With sweatband
- Adjustable

#	↑ mm	
120400	249	50





*So präsentieren Profis!*

MADE IN GERMANY

**Silikonfüße**

**Silicone feet**

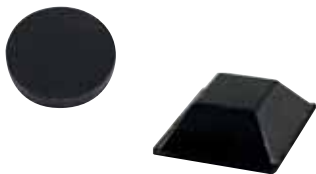

#	↔ mm
227142	rund Ø: 16 / Höhe: 2 (12 Stk.) round Ø: 16 / height: 2 (12 pcs.)
227144	quadratisch: oben: 20 x 20; unten: 10 x 10 / H: 7 (7 Stk.) square: top: 20 x 20; bottom: 10 x 10 / height: 7 (7 pcs.)

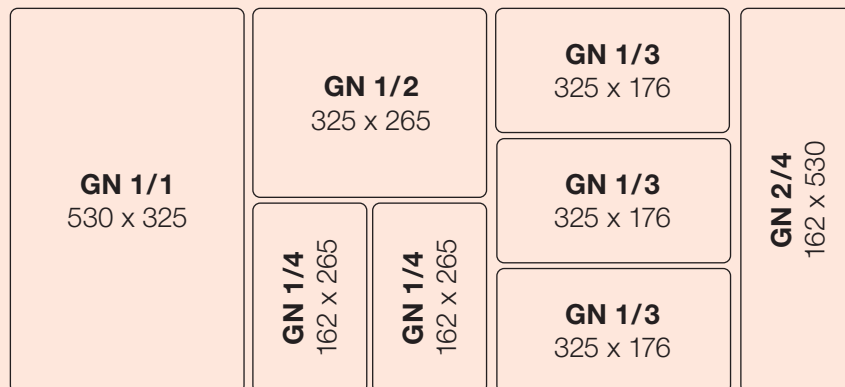
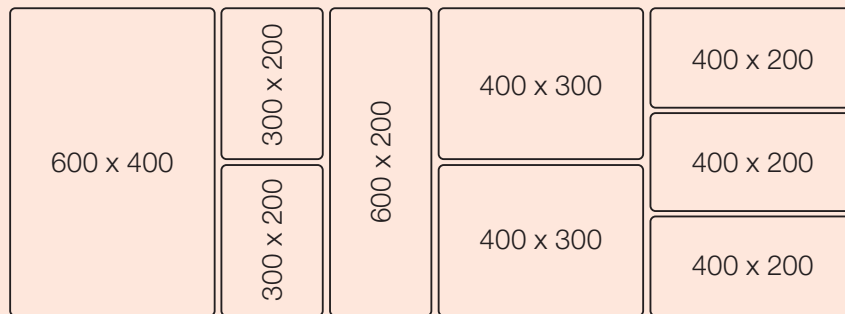

DE	AUSLAGETABLETTS "SCHIEFER"	
EN	DISPLAY TRAYS "SLATE"	
IT	VASSOI DA PRESENTAZIONE "ARDESIA"	
ES	BANDEJAS DE PRESENTACIÓN "PIZARRA"	

Material: mehrschichtige Kunststoffplatte

- Hygienisch, 100 % lebensmittelecht
- Spülmaschinengeeignet
- Leicht zu reinigen
- Stoß- und abriebfest
- Made in Germany
- Silikonfüße optional

**Materialstärke: 6 mm**

Made of multilayer plastic plate

- Hygienic, 100 % food safe
- Dishwasher proof
- Easy to clean
- Impact and abrasion resistant
- Made in Germany
- Optional accessory: silicone feet

**Thickness: 6 mm**



#		↔ mm	
225050		600 x 400	
225060		600 x 200	
225070		400 x 300	
225080		300 x 200	
225090		400 x 200	

225120		Ø: 320	
225130		Ø: 400	

225140	Tablett rund mit Griff / round tray with handle	Ø 320 x 465	
225150	Tablett rechteckig mit Griff / rectangular tray with handle	600 x 200	

9



**GN-Ausführungen**

**GN size display trays**

#	GN	↔ mm	
225250	1/1	530 x 325	
225260	1/2	325 x 265	
225270	1/3	325 x 176	
225280	1/4	265 x 162	
225290	2/4	530 x 162	



SAHARA  
DARK

DE	AUSLAGETABLETTS "SAHARA DARK"	
EN	TRAYS "SAHARA DARK"	
IT	VASSOI DA PRESENTAZIONE "SAHARA DARK"	
ES	BANDEJAS DE PRESENTACIÓN "SAHARA DARK"	

Material: mehrschichtige Kunststoffplatte

- Hygienisch, 100 % lebensmittelecht
- Spülmaschinengeeignet
- Leicht zu reinigen
- Stoß- und abriebfest
- Made in Germany
- Silikonfüße optional

**Materialstärke: 6 mm**

Made of multilayer plastic plate

- Hygienic, 100 % food safe
- Dishwasher proof
- Easy to clean
- Impact and abrasion resistant
- Made in Germany
- Optional accessory: silicone feet

**Thickness: 6 mm**

#		↔ mm	
226350		600 x 400	
226360		600 x 200	
226370		400 x 300	
226380		300 x 200	
226390		400 x 200	

226420		Ø: 320	
226430		Ø: 400	

226440	Tablett rund mit Griff / round tray with handle	Ø 320 x 465	
226450	Tablett rechteckig mit Griff / rectangular tray with handle	600 x 200	



**GN-Ausführungen**

**GN size display trays**

#	GN	↔ mm	
226550	1/1	530 x 325	
226560	1/2	325 x 265	
226570	1/3	325 x 176	
226580	1/4	265 x 162	
226590	2/4	530 x 162	



DE	AUSLAGETABLETTS "SAHARA LIGHT"
EN	DISPLAY TRAYS "SAHARA LIGHT"
IT	VASSOI DA PRESENTAZIONE "SAHARA LIGHT"
ES	BANDEJAS DE PRESENTACIÓN "SAHARA LIGHT"



Material: mehrschichtige Kunststoffplatte

- Hygienisch, 100 % lebensmittelecht
- Spülmaschinegeeignet
- Leicht zu reinigen
- Stoß- und abriebfest
- Made in Germany
- Silikonfüße optional

**Materialstärke: 6 mm**

Made of multilayer plastic plate

- Hygienic, 100 % food safe
- Dishwasher proof
- Easy to clean
- Impact and abrasion resistant
- Made in Germany
- Optional accessory: silicone feet

**Thickness: 6 mm**

#		↔ mm	
226650		600 x 400	
226660		600 x 200	
226670		400 x 300	
226680		300 x 200	
226690		400 x 200	
226720		Ø: 320	
226730		Ø: 400	
226740	Tablett rund mit Griff / round tray with handle	Ø 320 x 465	
226750	Tablett rechteckig mit Griff / rectangular tray with handle	600 x 200	



**GN-Ausführungen**

**GN size display trays**

#	GN	↔ mm	
226850	1/1	530 x 325	
226860	1/2	325 x 265	
226870	1/3	325 x 176	
226880	1/4	265 x 162	
226890	2/4	530 x 162	



DE	AUSLAGETABLETTS	MF
EN	DISPLAY TRAYS	
IT	VASSOI DA PRESENTAZIONE	
ES	BANDEJAS DE PRESENTACIÓN	

Alle Artikel aus **Melamin** sind:

- Schnitt- und kratzfest, stapelbar
- Temperaturbeständig von -30 °C bis +70 °C

All products made of **melamine** are:

- Scratch and cut proof, stackable
- Temperature resistant from -30 °C up to +70 °C

#	↔ mm	
227003	190 x 150 x 17	● Schwarz / black
227004	190 x 150 x 17	○ Weiß / white
227007	270 x 210 x 17	● Schwarz / black
227008	270 x 210 x 17	○ Weiß / white
227009	300 x 150 x 17	● Schwarz / black
227010	300 x 150 x 17	○ Weiß / white
227011	300 x 190 x 17	● Schwarz / black
227012	300 x 190 x 17	○ Weiß / white
227013	350 x 240 x 17	● Schwarz / black
227014	350 x 240 x 17	○ Weiß / white
227015	420 x 280 x 20	● Schwarz / black
227016	420 x 280 x 20	○ Weiß / white
227094	580 x 195 x 20	● Schwarz / black
227095	580 x 195 x 20	○ Weiß / white
227096	600 x 400 x 20	● Schwarz / black
227097	600 x 400 x 20	○ Weiß / white



DE	AUSLAGETABLETTS UND AUSLAGESCHALEN
EN	DISPLAY TRAYS
IT	VASSOI DA PRESENTAZIONE
ES	BANDEJAS DE PRESENTACIÓN



Für Metzgertheke / Fleischertheke mit 84 cm Tiefe. Silikonfüße optional.  
Alle Artikel aus **Melamin** sind:

- Spülmaschinengeeignet
- Schnitt- und kratzfest, stapelbar
- Temperaturbeständig von -30 °C bis + 70 °C

For counters in butcher shops with 84 cm depth, silicone feet optional  
All products made of **melamine** are:

- Dishwasher safe
- Scratch and cut proof, stackable
- Temperature resistant from -30 °C up to + 70 °C

#	↔ mm		ml
227130	280 x 210 x 22	● Schwarz / black	800
227131	280 x 210 x 43	● Schwarz / black	2600
227132	280 x 210 x 76	● Schwarz / black	2300
227133	420 x 280 x 22	● Schwarz / black	1600
227134	420 x 280 x 43	● Schwarz / black	3300
227135	420 x 280 x 76	● Schwarz / black	5600
227136	280 x 280 x 43	● Schwarz / black	1900
227137	280 x 280 x 76	● Schwarz / black	3800
227138	280 x 140 x 43	● Schwarz / black	900
227139	280 x 140 x 76	● Schwarz / black	1500
227140	210 x 140 x 43	● Schwarz / black	600
227141	210 x 140 x 76	● Schwarz / black	1100
227142	Silikonfüße (12 Stk.)	silicone feet (12 pcs.)	



DE	WURSTGABEL
EN	SAUSAGE FORK
IT	FORCHETTA PER SALSICCE
ES	TENEDOR PARA SALCHICHAS



#		A (mm)	B (mm)	C (mm)	D (mm)
177004	○	245	110	95	16
177005	●	245	110	95	16
177006	●	245	110	95	16
177007	●	245	110	95	16
177008	●	245	110	95	16
177009	●	245	110	95	16

- A** Gesamtlänge / total length
- B** Grifflänge / length of handle
- C** Zinkenlänge / length of tines
- D** Abstand der Zinken / distance between the tines

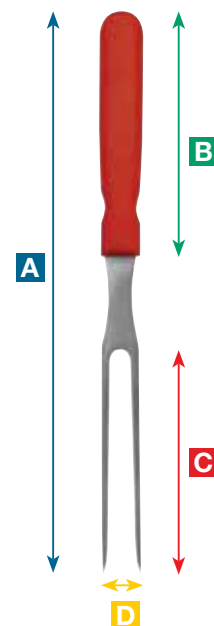

DE	SERVIERTABLETTS OVAL	SST
EN	SERVING TRAYS OVAL	
IT	VASSOI DA PORTATA OVALI	
ES	BANDEJAS OVALADAS	



- Mit gebördeltem Rand
- Hochglanzpoliert
- With rolled edge edge
- Mirror-polished

#	↔ mm	
154040	145 x 200	
154041	180 x 230	
154042	195 x 265	
154043	220 x 285	



- Mit gebördeltem Rand
- Oberfläche matt
- With rolled edge
- Matte finish

#	↔ mm	
155040	145 x 200	
155041	180 x 230	
155042	195 x 265	
155043	220 x 285	

DE	AUSLAGETABLETTS / SERVIERTABLETTS	SST
EN	DISPLAY TRAYS	
IT	VASSOI DA PRESENTAZIONE	
ES	BANDEJAS DE PRESENTACIÓN	



- Mit umgelegtem Rand
- Poliert
- With beaded edge
- Polished

#	↗ mm	→ mm	↑ mm	
154021	200	160	12	
154024	300	160	12	
154025	310	210	12	
154026	340	240	12	
154028	400	300	12	



- Mit geradem Rand
- Poliert
- With plain edge
- Polished

#	↗ mm	→ mm	↑ mm	
154030	195	145	10	
154031	280	140	10	
154032	290	185	10	
154033	320	220	10	
154034	380	280	10	

DE	KUCHEN- & TORTENPLATTEN / KÖNIGSKUCHENPLATTEN	<b>MF</b>
EN	CAKE PLATES	
IT	PIATTI PER DOLCI	
ES	SOPORTES PARA TARTAS	

Material: **Melamin**  
 • Schnitt- und bruchfest

Made of **melamine**  
 • Cut and break proof

#		↔ mm	
227023	Königskuchenplatte, weiß / loaf cake plate, white	400 x 150 x 20	
227098	Königskuchenplatte, schwarz / loaf cake plate, black	400 x 150 x 20	



DE	AUSLAGETABLETT	
EN	DISPLAY TRAY	
IT	VASSOIO DEL DISPLAY	
ES	BANDEJA DE DISPLAY	

#	↗ mm	→ mm	↑ mm	
227670	290	195	20	
227671	350	280	15	
227672	400	300	15	



DE	AUSLAGETABLETTS	
EN	DISPLAY TRAYS	
IT	VASSOI DA PRESENTAZIONE	
ES	BANDEJAS DE PRESENTACIÓN	

Material: ABS, schwarz  
 • Bruchfest, genarbt  
 • Randhöhe: 18 mm  
 • Abgeklappter Rand: 12 mm  
 • Spülmaschinengeeignet bis ca. + 80 °C  
 • Temperaturbeständig bis ca. + 80 °C

Made of ABS, black  
 • Unbreakable, surface grained  
 • Border height: 18 mm  
 • Curved rim: 12 mm  
 • Dishwasher safe up to approx. + 80 °C  
 • Heat resistant up to approx. + 80 °C

#	↗ mm	→ mm	
227640	400	300	



• Genarbt  
 • Spülmaschinengeeignet bis ca. + 80 °C  
 • Temperaturbeständig bis ca. + 80 °C

• Surface grained  
 • Dishwasher safe up to approx. + 80 °C  
 • Heat resistant up to approx. + 80 °C

#	↗ mm	→ mm	↑ mm	
227601	400	600	18	
227611	300	400	18	
227621	195	580	18	
227622	300	190	18	

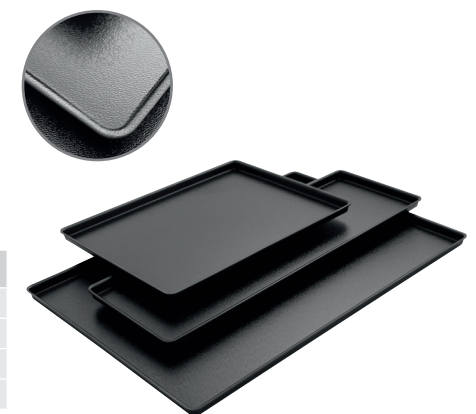



DE	AUSSTELLBLECHE / THEKENBLECHE	
EN	DISPLAY TRAYS	
IT	VASSOI DA ESPOSIZIONE	
ES	BANDEJAS PARA EXPOSICIÓN	

Material: Aluminium  
 • Pulverbeschichtet  
 • Farbe: schwarz

Made of aluminium  
 • Powder coated  
 • Color: black

**Ausführung / Type: 4 Seiten 90° / 4 sides 90°**

#	↗ mm	→ mm	↑ mm
154095	600	200	10
154096	600	400	10
154098	400	300	10
154099	300	200	10



**THEKENBLECHE MIT OFFENEN ECKEN**      **WITH OPEN EDGES**  
 Material: Edelstahl      Made of stainless steel

**Ausführung / Type: 4 Seiten 90° / 4 sides 90°**

#	↗ mm	→ mm	↑ mm
154060	600	400	15
154061	600	200	15



DE	THEKENABTRENNUNG
EN	COUNTER SEPARATOR
IT	SEPARATORE PER BANCO
ES	SEPARADOR DE MOSTRADOR

Material: Acryl      Made of acrylic

#	↔ mm
172700	700 x 170
172710	560 x 170

**NEW**



DE	AUSSTELLBLECHE	
EN	DISPLAY TRAYS	
IT	VASSOI DA ESPOSIZIONE	
ES	BANDEJAS PARA EXPOSICIÓN	

• Abgerundete Ecken      • Rounded corners

#	↗ mm	→ mm	↑ mm
154019	420	320	1,5

DE	AUSSTELLBLECHE / THEKENBLECHE	
EN	DISPLAY TRAYS	
IT	VASSOI DA ESPOSIZIONE	
ES	BANDEJAS PARA EXPOSICIÓN	

**SILBER**

Material: Aluminium, gebeizt

- Mit handelsüblichem Spülmittel reinigen
- Nicht spülmaschinengeeignet

**SILVER**

Made of pickled aluminium

- Cleaning with any standard detergent
- Not dishwasher safe

#	↗ mm	→ mm	↑ mm	
154050	600	400	20	
154051	480	320	20	
154052	400	250	20	
154053	600	200	20	
154059	300	200	20	
154054	600	400	10	
154055	480	320	10	
154056	400	250	10	



**GOLD**

Material: Aluminium, eloxiert

- Mit handelsüblichem Spülmittel reinigen
- Nicht spülmaschinengeeignet

**GOLD**

Made of anodized aluminium

- Cleaning with any standard detergent
- Not dishwasher safe

#	↗ mm	→ mm	↑ mm	
154070	600	400	20	
154071	480	320	20	
154072	400	250	20	
154074	600	200	20	
154073	600	400	10	



**CHAMPAGNER**

Material: Aluminium, eloxiert

- Mit handelsüblichem Spülmittel reinigen
- Nicht spülmaschinengeeignet

**CHAMPAGNE**

Made of anodized aluminium

- Cleaning with any standard detergent
- Not dishwasher safe

#	↗ mm	→ mm	↑ mm	
154080	600	400	10	
154081	480	320	10	
154082	400	300	10	
154083	400	250	10	
154084	600	200	10	



DE	THEKENBLECH / SNACK-BLECH	
EN	SNACK SALES RACK	
IT	TEGLIA PER SNACK	
ES	PORTA BOCADILLOS	

Material: Aluminium, pulverbeschichtet

- Schwarz
- Nicht spülmaschinengeeignet

Made of aluminium, powder coated

- Black
- Not dishwasher safe

#	↔ mm	
154089	600 x 200 x 20	





DE	SNACK-VERKAUFSSTÄNDER / SNACKWELLEN – WELLENFORM	
EN	SNACK SALES RACKS – WAVY	
IT	PORTA SNACK	
ES	PORTA BOCADILLOS	

**WELLENFORM**

Material: ABS, schwarz

- Bruchfest, genarbt
- Spülmaschinengeeignet bis ca. + 80 °C
- Temperaturbeständig bis ca. + 80 °C

**Optimal für # 227621**

**WAVY**

Made of ABS, black

- Unbreakable, surface grained
- Dishwasher safe up to approx. + 80 °C
- Heat resistant up to approx. + 80 °C

**Ideal for # 227621**

#	↗ mm	→ mm	↑ mm		
227651	560	85	58	6	
227650	560	168	58	6	



GN

Material: PS

- Matt-schwarz

Made of PS

- Matt black

#	↗ mm	→ mm	↑ mm		
227552	530	85	45	6	



Material: Acryl

- Transparent

Made of acryl

- Transparent

#	↗ mm	→ mm	↑ mm		
172500	580	85	45	6	
172510	580	170	45	6	



Material: Kunststoff

- Spülmaschinengeeignet

Made of plastic

- Dishwasher safe

#	↗ mm	→ mm	↑ mm		
227550	600	195	70	6	
227551	290	190	60	3	

DE	SNACK-VERKAUFSSTÄNDER / SNACKWELLEN – WELLENFORM
EN	SNACK SALES RACKS – WAVY
IT	PORTA SNACK
ES	PORTA BOCADILLOS



Material: Aluminium, schwarz  
 • Pulverbeschichtet,  
 • Nicht spülmaschinengeeignet

Made of aluminium, black,  
 • Powder coated  
 • Not dishwasher proof

#	↗ mm	→ mm	↑ mm	≡	
154090	580	85	40	6	
154091	580	170	40	6	



Material: Edelstahl  
 • Spülmaschinengeeignet

Made of stainless steel  
 • Dishwasher safe

#	↗ mm	→ mm	↑ mm	≡	
154065	370	85	35	4	
154066	370	175	35	4	
154093	560	85	35	7	
154094	560	175	35	7	

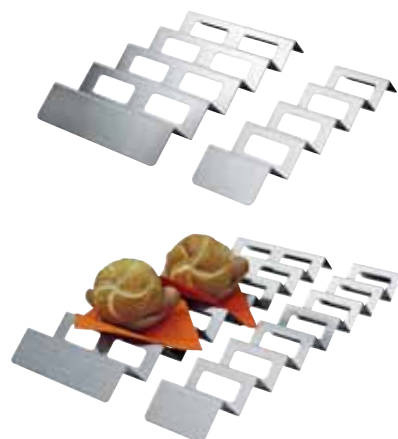

#	↗ mm	→ mm	↑ mm	≡	
154011	320	200	80	2	
154012	280	170	45	3	

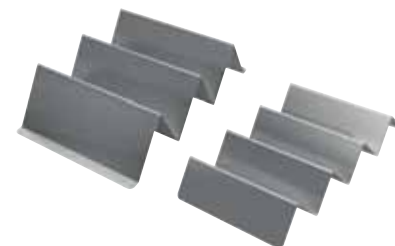

Material: Edelstahl, gelocht  
 • Spülmaschinengeeignet

Made of stainless steel, perforated  
 • Dishwasher safe

#	↗ mm	→ mm	↑ mm	≡	
154037	590	190	45	6	

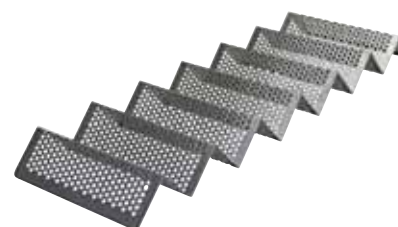

DE	WRAP-HALTER
EN	WRAP HOLDER
IT	PORTA WRAPS
ES	PORTA WRAPS

Material: Edelstahl

Made of stainless steel

#	↗ mm	→ mm	↑ mm	
172530	600	67	40	



Material: Acryl  
 • Transparent  
 • Mit Boden  
 • Zur Präsentation von 12 Wraps  
 • Lochdurchmesser 70 mm

Made of acryl  
 • Transparent  
 • With bottom  
 • For the presentation of 12 wraps  
 • Diameter of holes 70 mm

#	↗ mm	→ mm	↑ mm	
172520	560	195	50	



DE	TORTENPLATTEN / HALBKREIS	
EN	CAKE PLATES	MF
IT	ALZATE PER TORTA	
ES	SOPORTES PARA TARTAS	

**Tortenplatte-Halbkreis** in zwei Farben – aus dickwandigem **Melamin**

- Temperaturbeständig von -30 °C bis +70 °C
- Schnitt- und kratzfest, stapelbar
- Spülmaschinengeeignet
- Mit Silikonfüßen

**Cake display** in 2 colors: heavy, high quality **melamine**; **semi-circle**

- Temperature resistant -30 °C up to +70 °C
- Scratch and cut proof, stackable
- Dishwasher safe
- Silicone feet included



#		↔ mm / Ø	↑ mm
227026	○ Weiß / white	160 / 320	30
227126	● Schwarz / black	160 / 320	30



DE	TORTENPLATTEN	
EN	CAKE PLATES	MF
IT	ALZATE PER TORTA	
ES	SOPORTES PARA TARTAS	

Material: **Melamin**

- Schnitt- und bruchfest
- Mit Anti-Rutsch-Füßen

Made of **melamine**

- Cut and break proof
- With anti-slip feet



# 227029, 227025, 227027



# 227129, 227125, 227127

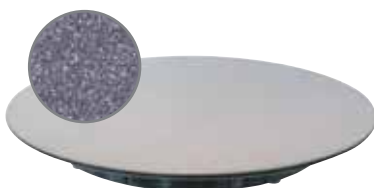

# 227229, 227225, 227227

#		Ø mm	↑ mm
227029	○ Weiß / white	240	30
227025	○ Weiß / white	300	30
227027	○ Weiß / white	320	30
227129	● Schwarz / black	240	30
227125	● Schwarz / black	300	30
227127	● Schwarz / black	320	30
227229	● Silber / silver	240	30
227225	● Silber / silver	300	30
227227	● Silber / silver	320	30



DE	TORTENPLATTEN		
EN	CAKE PLATES	MF	drehbar
IT	ALZATE PER TORTA		
ES	SOPORTES PARA TARTAS		

- Material: **Melamin**
- Schnitt- und bruchfest
  - Mit Anti-Rutsch-Füßen

- Made of **melamine**
- Cut and break proof
  - With anti-slip feet

#		Ø mm	↑ mm
227028	weiß, drehbar, mit Fuß / white, turnable, with foot	320	100
227128	schwarz, drehbar, mit Fuß / black, turnable, with foot	320	100



DE	TORTEN- UND DEKORIERPLATTE			
EN	TILTING CAKE DECORATING	MF	drehbar	
IT	ALZATA GIREVOLE E INCLINABILE PER DECORARE TORTE			
ES	SOPORTE GIRATORIO INCLINABLE PARA DECORAR TARTAS			

- Material: **Melamin, Kunststoff**
- Dreh- und schwenkbar
  - Stabile Qualität
  - Inkl. Anti-Rutsch-Füßen
  - rutschfeste Oberfläche

- Made of **melamine, plastic**
- Turnable
  - Tilting
  - Sturdy
  - With anti-slip feet and top

#	Ø mm	↑ mm
227220	300	160



DE	TORTENPLATTE		
EN	CAKE PLATE	ALU	drehbar
IT	ALZATE PER TORTA		
ES	SOPORTES PARA TARTAS		

- Material: **Aluminium**
- Drehbar
  - Stabile Qualität
  - Anti-Rutsch Boden

- Made of **aluminium**
- Turnable
  - Sturdy
  - Anti-slip bottom

#	Ø mm	↑ mm
154018	310	130

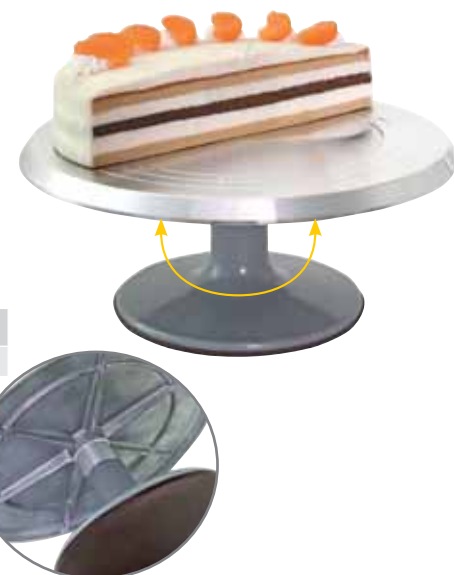



DE	TORTENPLATTEN
EN	CAKE PLATES
IT	ALZATE PER TORTA
ES	SOPORTES PARA TARTAS

Material: Edelstahl  
 • Poliert  
 • Mit Ringfuß  
 • Materialstärke: 1 mm

Made of stainless steel  
 • Polished  
 • With round foot  
 • Thickness: 1 mm

#	Ø mm	↑ mm	
154010	240	30	
154001	300	30	
154002	330	30	
154004	360	30	

**i** Andere Größen auf Anfrage. / Other sizes upon request.



Material: Edelstahl  
 • Matt poliert  
 • Mit geschlossenem Boden  
 • Bodenteil aus einem Stück  
 • Materialstärke: 3,2 mm

Made of stainless steel  
 • Matte finish, hygienic  
 • With closed bottom  
 • Closed bottom part  
 • Thickness: 3.2 mm

#	↑ Ø mm	↓ Ø mm	↑ mm	
154003	315	220	35	



DE	TORTENPLATTE, RECHTECKIG
EN	CAKE PLATE, RECTANGULAR
IT	ALZATA RETTANGOLARE PER TORTE
ES	SOPORTE RECTANGULAR PARA TARTAS

Material: Edelstahl

Made of stainless steel

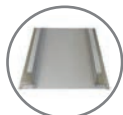
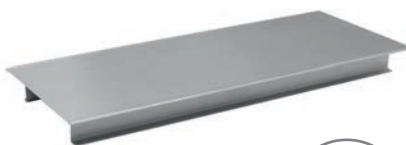

#	↔ mm	↑ mm	
154020	395 x 160	30	

DE	ABDECKHAUBE						
EN	DISPLAY COVER	PS	0 +70 °C				
IT	COPERTURA						
ES	CUBIERTA						

#	Ø mm	↑ mm
227150	300	70
227160	300	100
227170	335	120



#227160

DE	ABDECKHAUBE						
EN	DISPLAY COVER	PP	0 +100 °C				
IT	COPERTURA						
ES	CUBIERTA						

#	Ø mm	↑ mm
227031	300	120



DE	ABDECKHAUBE						
EN	DISPLAY COVER	PP	0 +95 °C				
IT	COPERTURA						
ES	CUBIERTA						

#	Ø mm	↑ mm
227037	300	110



DE	ABDECKHAUBE						
EN	DISPLAY COVER	PET	60x40	0 +50 °C			
IT	COPERTURA						
ES	CUBIERTA						

- Geeignet für Bleche 60x40
- Suitable for trays 60x40

#	↗ mm	→ mm	↑ mm
227180	620	425	105

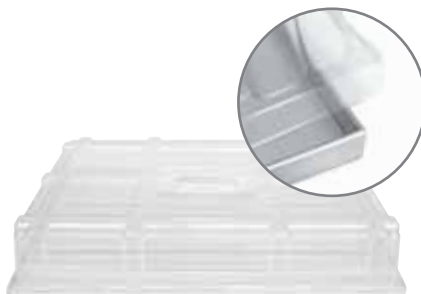



DE	SAHNE-ABDECKPAPIERE "ZELLGLAS"
EN	CREAM COVERS "CELLOPHANE"
IT	FOGLIETTI SEPARATORI PER ALIMENTI "CELOFAN"
ES	HOJAS SEPARADORAS PARA REPOSTERÍA "CELOFÁN"

Zellglas, transparent  
 • Flächengewicht 35 g/m<sup>2</sup>

Made of cellophane, transparent  
 • Grammage 35 g/m<sup>2</sup>

#	↗ mm	→ mm		🛒 kg
114001	120	180	1/32	5
114002	180	240	1/16	5
114003	240	360	1/8	5



DE	SAHNE-ABDECKPAPIERE "NON PLUS ULTRA"
EN	CREAM COVERS "NON PLUS ULTRA"
IT	FOGLIETTI SEPARATORI PER ALIMENTI "NON PLUS ULTRA"
ES	HOJAS SEPARADORAS PARA REPOSTERÍA "NON PLUS ULTRA"

• Im Spendenkarton à 1000 Blatt  
 • Sehr hohe Fettdichte  
 • Kompostierbar

• In dispenser box à 1000 sheets  
 • Very high grease density  
 • Compostable

#	↗ mm	→ mm	🛒 Blatt
113040	120	180	1000
113041	180	240	1000
113042	240	360	1000



DE	FETTPAPIERHALTER
EN	DISPENSERS FOR GREASE-PROOF PAPERS
IT	DISPENSER PER CARTA RESISTENTE AI GRASSI
ES	DISPENSADOR DE PAPEL MANTEQUILLA

Material: Acryl, transparent  
 • Selbstklemmend

Made of acryl, transparent  
 • Self-mounting

#		↔ mm
172000	zur Ablage von DIN A 6-Papieren / storage and dispensing of paper sheets (ca. 125 x 187 mm)	130 x 190 x 65
172001	zur Ablage von DIN A 6-Papieren / storage and dispensing of paper sheets (ca. 125 x 187 mm)	190 x 135 x 65
172002	zur Ablage von DIN A 5-Papieren / storage and dispensing of paper sheets (ca. 187 x 250 mm)	263 x 190 x 52
172003	zur Ablage von DIN A 4-Papieren / storage and dispensing of paper sheets (ca. 250 x 375 mm)	380 x 260 x 65

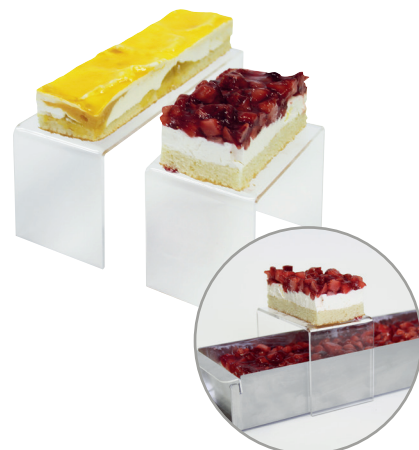

DE	PRÄSENTIER-STÄNDER / SCHNITTKUCHENBRÜCKE
EN	DISPLAY RISER FOR SLICED CAKES
IT	ALZATA ESPOSITORE PER TORTE A FETTE
ES	SOPORTE PARA REBANADAS DE PASTELES

Material: Acryl, transparent

Made of acrylic, transparent

#	für/for #	→ mm	↑ mm	↓ mm
227575	995810 + 997810	106	80	70
227576	995820 + 997820	206	80	70

DE	RAHMEN FÜR SCHNITTKUCHENBLECH	
EN	FRAME FOR CAKE DISPLAY SHEET	 <div style="border: 1px solid black; padding: 2px; display: inline-block;">PS</div>
IT	BASE PER TEGLIE PORTA TORTE	
ES	CONTENEDORES DE BANDEJAS PARA TORTA	

- Genarbt, schwarz
- Eine kurze Seite offen
- Surface grained, black
- One short side open

#	für/for #	→ mm	↑ mm	↓ mm
227577	995810 + 997810	115	55	590
227578	995820 + 997820	215	55	590



DE	TORTENSCHUTZ TS PLAST 1 + 2 GES. GESCH.	
EN	CAKE PROTECTION TS PLAST 1 + 2 PAT.	<div style="border: 1px solid black; padding: 2px; display: inline-block;">HPVC</div>
IT	PROTEZIONE PER TORTA TS PLAST 1 + 2	
ES	PROTECCIÓN PARA TORTA TS PLAST 1 + 2	

- Glasklar
- Bewahrt den Torten-Anschnitt vor Austrocknung und schützt das Aroma
- Transparent
- Protects the aroma by preventing the desiccation of the sliced cake

#		
113500	Set besteht aus je 25 linken und rechten Teilen Set consisting of 25 left and right pieces	1 Set = 50 Stück



**i** TS Plast 1 und 2 reinigt man mit lauwarmem Wasser (bis zu 50 °C) unter Zugabe eines beliebigen Spülmittels / cleaning of TS Plast 1+2 with warm water (max. 50 °C) and standard washing-up liquid

DE	TORTENRANDFOLIE-STREIFEN	
EN	CAKE RIBBON STRIPS	<div style="border: 1px solid black; padding: 2px; display: inline-block;">PVC</div>
IT	STRISCE DI FOGLIO PER TORTA	
ES	BANDAS DE FOLIO PARA TARTA	

#	↗ mm	↑ mm	μ	
114021	300	60	50	1 Pack à 1000
114022	240	40	50	1 Pack à 1000
114023	240	30	50	1 Pack à 1000
114024	150	25	50	1 Pack à 1500
114060	600	400	80	1 Pack à 50
114061	300	300	80	1 Pack à 50



#114021

DE	TORTENRANDFOLIE	
EN	CAKE RIBBON	<div style="border: 1px solid black; padding: 2px; display: inline-block;">PVC</div>
IT	FOGLIO PER TORTA	
ES	FOLIO PARA TARTA	

#	↗ m	↑ mm	μ
114026	300	40	37
114030	300	60	37
114050	200	25	80
114051	200	30	80
114052	200	35	80
114053	200	40	80
114054	200	45	80
114055	200	50	80
114056	200	55	80
114057	200	60	80



#114026

DE	TORTENSPITZEN, WEISS
EN	DOILIES, WHITE
IT	PIZZI PER TORTE, BIANCHI
ES	BLONDAS BLANCAS



#		Ø mm			
116010	rund / round	100	250	5000	
116013	rund / round	120	250	2000	
116014	rund / round	140	250	2000	
116017	rund / round	165	250	2000	
116018	rund / round	190	250	2000	
116022	rund / round	220	100	2000	
116026	rund / round	240	100	2000	
116028	rund / round	270	100	2000	
116030	rund / round	290	100	2000	
116033	rund / round	300	100	2000	
116034	rund / round	320	100	2000	
116036	rund / round	340	100	1000	
116038	rund / round	360	100	1000	
116040	rund / round	380	100	1000	
116046	rund / round	420	100	1000	

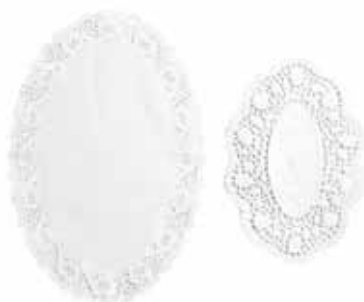

#		↔ mm			
116100	oval	180 x 260	250	10000	
116110	oval	160 x 230	250	2000	
116130	oval	210 x 320	250	2000	
116210	oval	320 x 450	100	2000	
116410	Rechteckig / rectangular	170 x 300	100	1000	
116430	Rechteckig / rectangular	200 x 400	100	1000	
116440	Rechteckig / rectangular	300 x 400	100	1000	
116450	Rechteckig / rectangular	350 x 450	100	1000	
116480	Rechteckig / rectangular	250 x 370	100	1000	

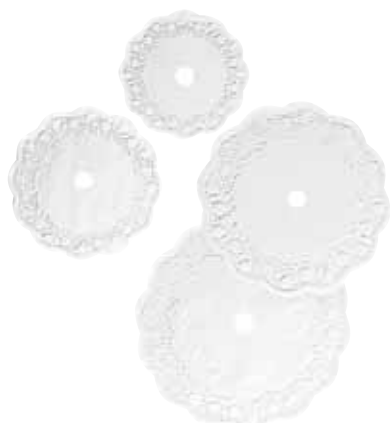

DE	TORTENSPITZEN-SET
EN	SET OF DOILIES FOR CAKE STANDS
IT	SET DI PIZZI PER TORTE
ES	JUEGO DE BLONDAS

- Für 3- und 4-teilig Tortenständer
- For cake stands with 3 and 4 tiers

#	für/for Ø mm	Set
116333	3-teilig / 3-tiers (200 / 260 / 320)	à 100 Stk./pcs.
116444	4-teilig / 4-tiers (200 / 260 / 320 / 400)	à 100 Stk./pcs.

DE	ETAGEN-TORTENSTÄNDER / HOCHZEITSTORTENSTÄNDER
EN	CAKE STANDS
IT	ALZATE PER TORTA IN ALLUMINIO
ES	SOPORTES PARA TARTAS EN ALUMINIO

Material: Aluminium

- Für Hochzeiten, Büffets in der Gastronomie oder für Warenpräsentationen
- Sehr stabile Ausführung

• **Abstand zwischen den Etagen 16,5 cm**

Made of aluminium

- Usable for wedding cakes, buffets or for displaying pastries etc.
- Sturdy

• **Distance between tiers 16.5 cm**

#	Ø mm		↑ mm
146003	200/260/320	3	380
146004	200/260/320/400	4	546
146005	200/260/320/400/450	5	712
146006	200/260/320/400/450/500	6	878
146007	160/200/260/320/400/450/500	7	1044
146008	160/200/260/320/400/450/500/550	8	1210



# 146003



# 146004



# 146005



# 146007

9

DE	ERSATZTEILE
EN	SPARE PARTS
IT	PEZZI DI RICAMBIO
ES	PIEZAS DE REPUESTO

#		↔ mm
148016	Ersatzscheibe / disc	160
148020	Ersatzscheibe / disc	200
148026	Ersatzscheibe / disc	260
148032	Ersatzscheibe / disc	320
148040	Ersatzscheibe / disc	400
148045	Ersatzscheibe / disc	450
148050	Ersatzscheibe / disc	500
148051	Ersatzscheibe / disc	550
148002	Kopfschraube / head screw	
148003	Schraube für Fuß / screw for foot	
148004	Außenfuß mit Schraube / outside foot with screw	
148005	Zwischenstück (Säule) / connection (pillar) 165	
148007	Zwischenstück (Säule) / connection (pillar) 82	
148008	Zwischenstück (Säule) / connection (pillar) 52	
148006	Mittelfuß / middle foot	
148001	Mittellochsausstecher aus Edelstahl / center hole cutter made of stainless steel	



# 148001



#148008 #148007 #148005



DE	ETAGEN-TORTENSTÄNDER / HOCHZEITSTORTENSTÄNDER
EN	CAKE STANDS
IT	ALZATE PER TORTA
ES	SOPORTES PARA TARTAS

Material: PS

Made of PS

#	☐	Ø mm	
200108	2	250 / 340	
200103	3	200 / 250 / 340	
200104	4	200 / 250 / 320 / 340	
200105	5	200 / 250 / 320 / 400 / 440	

Ersatzteile / Spare parts

200106	Mittelfuß / Middle foot (PP)	
200102	Schraube / Screw	
200109	Zwischenstück / Intermediate piece	



DE	ETAGEN-TORTENSTÄNDER / HOCHZEITSTORTENSTÄNDER
EN	CAKE STANDS
IT	ALZATE PER TORTA
ES	SOPORTES PARA TARTAS

Material: weißer Kunststoff

Made of white plastic

- Spülmaschinenfest
- Zur einmaligen oder mehrmaligen Verwendung
- Stecksystem – einfach zu montieren
- Jede Scheibe benötigt 4 Säulen
- Dishwasher safe
- For single or multiple use
- Plug-in system – easy to install
- Each disc requires 4 columns

#	Ø mm	
202400	150	
202401	175	
202402	200	
202403	225	
202404	250	
202405	275	
202406	300	
202407	325	
202408	350	
202409	375	
202410	400	
202411	450	



#	↑ mm	
202412	75	
202413	150	
202414	225	



DE	ETAGEN-TORTENSTÄNDER / HOCHZEITSTORTENSTÄNDER
EN	CAKE STANDS
IT	ALZATE PER TORTA
ES	SOPORTES PARA TARTAS

Material: Aluminium

- Sehr stabile Ausführung
- Für Hochzeiten, Büffets in der Gastronomie oder für Warenpräsentationen
- **Individuell gestaltbar**

Made of aluminium

- Sturdy
- Usable for wedding cakes, buffets or for displaying pastries etc.
- **Individually designable**



#		↑ mm	Ø mm	
146040	5	380	200/2 x 260/2 x 320	



DE	TORTENHEBER
EN	CAKE SERVERS
IT	PALETTE PER TORTA
ES	PALETAS PARA TORTAS

Material: Edelstahl

Made of stainless steel

#		↕ mm	↗ mm	
199030	aus einem Stück, schwere Qualität / in one piece, heavy quality	128 x 55	275	
199035	aus einem Stück, rechteckig / in one piece, rectangular	120 x 60	240	
199036	aus einem Stück, mit Spitze / in one piece, pointed	120 x 55	240	
<input checked="" type="checkbox"/> 149900	poliert / polished		Ø: 280	



DE	TORTENHEBER
EN	CAKE SERVERS
IT	PALETTE PER TORTA
ES	PALETAS PARA TORTAS

Material: Edelstahl

Made of stainless steel

- Kunststoffgriff, schwarz

- Plastic handle, black

#		↕ mm	↗ mm	
<input checked="" type="checkbox"/> 199038	stumpf / blunt	105 x 63	275	
<input checked="" type="checkbox"/> 199039	Welle / Wave	105 x 63	275	

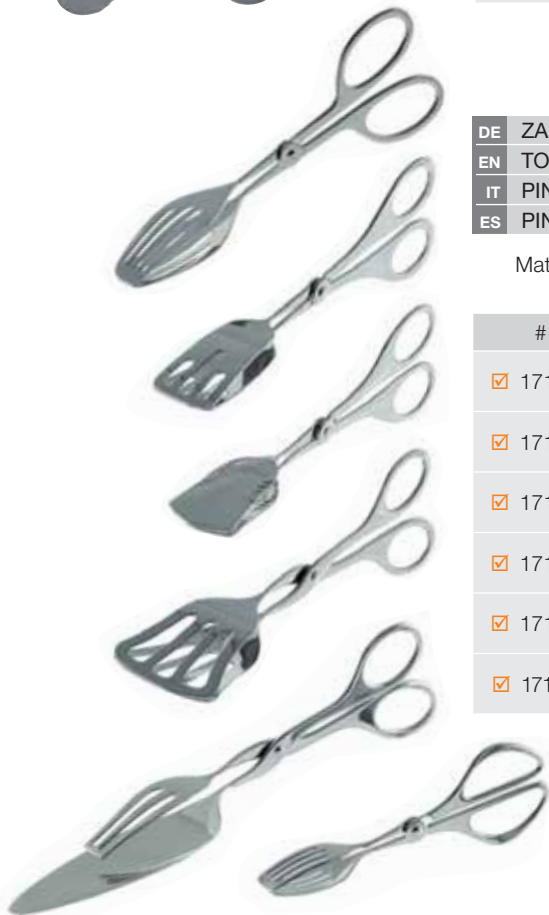

DE	ZANGEN
EN	TONGS
IT	PINZE
ES	PINZAS

Material: Edelstahl, aus einem Stück

Made of stainless steel, in one piece

#		↔ mm	
<input checked="" type="checkbox"/> 171000	Gebäckzange, offen / pastry tongs, open	190 x 36	
<input checked="" type="checkbox"/> 171001	Gebäckzange, offen / pastry tongs, open	185 x 34	
<input checked="" type="checkbox"/> 171002	Gebäckzange, offen / pastry tongs, open	180 x 36	
<input checked="" type="checkbox"/> 171003	Gebäckzange, offen / pastry tongs, open	190 x 56	
<input checked="" type="checkbox"/> 171004	Tortenzange / cake tongs	230 x 20 x 53	
<input checked="" type="checkbox"/> 171005	Konfektzange, offen / confectionery tongs, open	145 x 21	

DE	NUDELZANGEN
EN	PASTA TONGS
IT	PINZE PER LA PASTA
ES	PINZAS PARA PASTA

- Material: Edelstahl
- Poliert
  - Aus einem Stück

- Made of stainless steel
- Polished
  - In one piece

#	↗ mm	↔ mm	
<input checked="" type="checkbox"/> 171100	205	80 x 35	



DE	SALATZANGEN
EN	SALAD TONGS
IT	PINZE PER INSALATA
ES	PINZAS PARA ENSALADA

- Material: Edelstahl
- Poliert
  - Aus einem Stück

- Made of stainless steel
- Polished
  - In one piece

#	↗ mm	↔ mm	
<input checked="" type="checkbox"/> 171101	240	75 x 50	



DE	UNIVERSALZANGEN
EN	CATERING TONGS
IT	PINZA UNIVERSALE
ES	PINZA UNIVERSAL

- Material: Edelstahl
- Poliert
  - Aus einem Stück

- Made of stainless steel
- Polished
  - In one piece

#	↗ mm	↔ mm	
<input checked="" type="checkbox"/> 171103	210	50 x 38	
<input checked="" type="checkbox"/> 171104	215	68 x 48	
<input checked="" type="checkbox"/> 171105	210	50 x 38	



DE	SANDWICH ZANGEN
EN	SANDWICH TONGS
IT	PINZE PER PANINI
ES	PINZAS PARA SANDWICHES

- Material: Edelstahl
- Poliert
  - Aus einem Stück

- Made of stainless steel
- Polished
  - In one piece

#	↗ mm	↔ mm	
<input checked="" type="checkbox"/> 171106	190	75 x 32	





DE	BREZEL-/ WURSTSTÄNDER		
EN	PRETZEL/ SAUSAGE STAND	SST	
IT	PORTA PRETZEL/ SALSICCIA		
ES	SOPORTE PARA PRETZELS Y SALCHICHAS		

- Selbstmontage
- Ausführung: 8-armig
- Self-assembly
- Type: with 8 arms

#	Ø mm	↑ mm	
154812	210	500	



DE	BREZEL-/ WURSTSTÄNDER		
EN	PRETZEL/ SAUSAGE STAND	WOOD	
IT	PORTA PRETZEL/ SALSICCIA		
ES	SOPORTE PARA PRETZELS Y SALCHICHAS		

- Ausführung: 6-armig
- Type: with 6 arms

#	Ø mm	↑ mm	
120641	150	500	



DE	SPUCK / NIESSCHUTZ		
EN	PROTECTION		
IT	PROTEZIONE		
ES	PROTECCIÓN		

Material: Acryl

Made of acrylic

#	Ø mm	↑ mm	
172401	370	500	

DE	ALLZWECKZANGEN
EN	MULTI PURPOSE TONGS
IT	PINZE MULTIUSO
ES	PINZAS MULTIUSOS

- Material: Edelstahl
- Griff Kunststoff
  - Schwere Qualität

- Made of stainless steel
- Plastic handle
  - Heavy quality

#		↗ mm
<input checked="" type="checkbox"/> 171040	● Schwarz/black	230
<input checked="" type="checkbox"/> 171041	● Schwarz/black	300
<input checked="" type="checkbox"/> 171042	● Schwarz/black	400
<input checked="" type="checkbox"/> 171061	● Rot/red	300
<input checked="" type="checkbox"/> 171062	● Blau/blue	300
<input checked="" type="checkbox"/> 171063	● Grün/green	300
<input checked="" type="checkbox"/> 171064	● Gelb/yellow	300

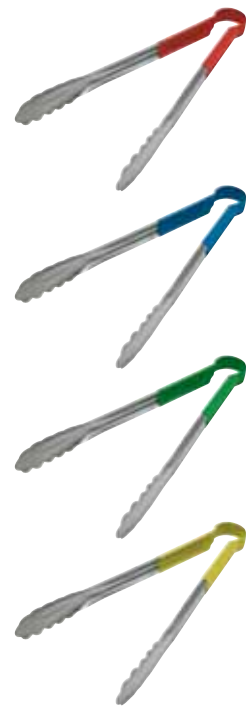

DE	ALLZWECKZANGEN
EN	MULTI PURPOSE TONGS
IT	PINZE MULTIUSO
ES	PINZAS MULTIUSOS

- Material: Edelstahl
- Griff und Blatt aus Silikon
  - Mit Verschleißmechanismus und Aufhänge-Öse
  - Schwere Qualität

- Made of stainless steel
- Handle and blade made of silicone
  - With closing mechanism and suspension eyelet
  - Heavy quality

#		↗ mm
<input checked="" type="checkbox"/> 171050	● Schwarz/black	230
<input checked="" type="checkbox"/> 171051	● Schwarz/black	300
<input checked="" type="checkbox"/> 171052	● Schwarz/black	400



9

DE	GRILL / SERVIERZANGEN
EN	GRILL /SERVING TONGS
IT	PINZE PER BARBECUE
ES	PINZAS PARA BARBACOA

Material: Edelstahl

Made of stainless steel

#		↗ mm
172415		220
172416		320





DE	WINKELPALETTEN
EN	ANGULAR SPATULAS
IT	SPATOLE ANGOLARI
ES	ESPÁTULAS CURVADAS

Material: Aluminium

Made of aluminium

#	↖ mm	→ mm	
227214	175 / 310	35	



DE	WURSTZANGEN
EN	SAUSAGE TONGS
IT	PINZE PER SALSICCE
ES	PINZAS PARA SALCHICHAS

Material: Edelstahl

Made of stainless steel

- Aus einem Stück
- Greifende gewellt

- Seamless
- Gripping end wavy

#		↔ mm	
172413	gebogen / bended	339 x 50 x 60	
172414	gerade / straight	354 x 68 x 24	



DE	PINZETTEN ZANGEN
EN	PRECISION TWEEZER TONGS
IT	PINZE DI PRECISIONE
ES	PINZAS DE PRECISIÓN

Material: Edelstahl

Made of stainless steel

#		↔ mm	
171020	gerade / straight	200	
171030	gebogen / bended	200	



Material: PPA, schwarz

Made of PPA, black

- Hitzebeständig bis + 220 °C

- Heat resistant up to + 220 °C

#		↔ mm	
<input checked="" type="checkbox"/> 172370	Pinzette / tweezers	305 x 18	



DE	THEKENPRÄSENTER
EN	SHOWCASES
IT	ESPOSITORI DA BANCO
ES	VITRINAS EXPOSITORAS

Material: PC

Made of PC

- Transparent
- 2-teilig

- Transparent
- 2 pieces

#	↗ mm	→ mm	↑ mm	
172670	430	280	140	

DE	THEKENAUFSTELLER
EN	SHOWCASES
IT	VETRINE DA BANCO
ES	VITRINAS EXPOSITORAS

Material: Acryl

• Mit 3 Auslagetabletts aus PC

• Mit hochklappbarem Entnahmedeckel

Made of acrylic

• With 3 trays made of PC

• With removable flip lid

#	↗ mm	→ mm	↑ mm
172630	340	250	340



Material: Acryl

Made of acrylic

#		↔ mm
172600	für 1 Blech 200 x 600 mm / for 1 tray 200 x 600 mm	635 x 260 x 200
172610	für 2 Bleche 200 x 600 mm / for 2 trays 200 x 600 mm	635 x 260 x 400



DE	THEKENAUFSTELLER FÜR HYGIENISCHEN SCHUTZ / SPUCKSCHUTZ
GB	COUNTER SHOWCASE WITH SNEEZE GUARD
IT	PARAFIATO DA BANCO CON MENSOLA
ES	VITRINA MAMPARA PARA BARRA DE PROTECCION HIGIÉNICA

Material: Acryl, farblos

• Gebogene Form

• Materialstärke: 4 mm

Made of acrylic

• Bent shape

• Thickness: 4 mm

#	↗ mm	→ mm	↑ mm
172431	600	220	200
172432	540	220	200



Material: Acryl

• Für Tablett und Bleche

200 x 600 mm + 400 x 600 mm

Made of acrylic

• For trays 200 x 600 mm

+ 400 x 600 mm

#	↗ mm	→ mm	↑ mm
172430	610	290	300



DE	KÜHLPLATTEN
EN	COOLING TRAYS
IT	VASSOI REFRIGERATI
ES	BANDEJAS REFRIGERADAS



- Material: Edelstahl  
 • Integrierte Kühlelemente fest verschlossen  
 • Bei -20° ca. 4 Stunden gefrieren
- Made of stainless steel  
 • Integrated cooling elements firmly closed  
 • Freeze at -20° for approx. 4 hours

#		↗ mm	→ mm	↑ mm
281020	GN 1/1	530	325	45
281021	GN 1/2	325	265	45



DE	TISCHAUFSTELLER / PREISSCHILDER
EN	TABLETOP MENU BOARDS
IT	LAVAGNETTE DA TAVOLA
ES	PIZZARAS DE MESA



- Ausführung: L-Form**  
 Material: PVC, schwarz  
 • Materialstärke: 3 mm  
 • Mit Kreidestiften zu beschriften  
 • Abwischbar  
 • Set à 5 Stk.

- Design: L-shape**  
 Material: PVC, black  
 • Thickness: 3 mm  
 • Can be written on with chalk markers  
 • Wipeable  
 • Set of 5 pcs.

#	→ mm	↑ mm	
198950	105	148	DIN A6
198951	148	210	DIN A5
198952	210	297	DIN A4



- Ausführung: mit lackiertem Naturholzfuß**  
 Material: PVC, schwarz  
 • Materialstärke: 3 mm  
 • Mit Kreidestiften zu beschriften  
 • Abwischbar

- Design: with lacquered natural wood base**  
 Material: PVC, black  
 • Thickness: 3 mm  
 • Can be written on with chalk markers  
 • Wipeable

#	→ mm	↑ mm	
198960	138	65	
198961	138	105	
198962	138	190	

DE	KREIDESTIFTE
EN	CHALK MARKERS
IT	PENNARELLI A GESSO LIQUIDO
ES	MARCADORES DE YESO LÍQUIDO

- Mit feuchtem Tuch und Wasser abwischbar
- Schreibt auf allen glatten Oberflächen (Kreidetafeln, Glas, Spiegel, Kunststoff, Metall, Fliesen, etc.)
- Clean with water
- Writes on all glossy surfaces (chalkboards, glass, mirrors, plastics, metals, tiles, etc.)

#		→ mm
198920	○ Weiß / white	2
198900	○ Weiß / white	5
198901	● Blau / blue	5
198902	● Gelb / yellow	5
198903	● Grün / green	5
198904	● Orange / orange	5
198905	● Rot / red	5
198910	○ Weiß / white	15
198911	● Blau / blue	15
198912	● Gelb / yellow	15
198913	● Grün / green	15
198914	● Orange / orange	15
198915	● Rot / red	15











DE	KELLNER-/NOTABLOCKS
EN	WAITER PADS
IT	BLOC-NOTES PER CAMERIERI
ES	COMANDAS PARA CAMAREROS

- Neutrale Blocks
- 40 Blatt pro Block
- Farblose Kopfverleimung
- Verpackung: 2 x 25 Blocks in Folie
- Unprinted
- 40 sheets
- Colorless glue
- 2 x 25 notepads packed

#	↔ mm		
711000	70 x 150	holzfrei, weiß / woodfree 60 g / m <sup>2</sup>	50
710000	70 x 150	Zeitungsdruckpapier / newsprint / 49 g / m <sup>2</sup>	50





	MEHRWEG	MULTI USE
 	<p><b>„MASTERFLEX“</b></p> <ul style="list-style-type: none"> <li>• Für höchste Ansprüche, 100% lebensmittelecht</li> </ul>	<p><b>„MASTERFLEX“</b></p> <ul style="list-style-type: none"> <li>• For top requirements, 100 % food-safe</li> </ul>
 	<p><b>„EXPORT“</b></p> <ul style="list-style-type: none"> <li>• Dickes Material</li> <li>• Für den Konditor</li> <li>• Mit Tüllenverstärkung</li> <li>• Mit oberem Saum und Aufhänger</li> </ul>	<p><b>„EXPORT“</b></p> <ul style="list-style-type: none"> <li>• Thick material</li> <li>• For the confectioner</li> <li>• With reinforced tip</li> <li>• With upper seam and hanger</li> </ul>
 	<p><b>„STANDARD“</b></p> <ul style="list-style-type: none"> <li>• Softe Oberfläche</li> <li>• Mit Tüllenverstärkung</li> <li>• Mit oberem Saum und Aufhänger</li> </ul>	<p><b>„STANDARD“</b></p> <ul style="list-style-type: none"> <li>• Soft surface</li> <li>• With reinforced tip</li> <li>• With upper seam and hanger</li> </ul>
 	<p><b>„PREMIUM“</b></p> <ul style="list-style-type: none"> <li>• Flexibel</li> <li>• Synthetik</li> <li>• Mit oberem Saum und Aufhänger</li> </ul>	<p><b>„PREMIUM“</b></p> <ul style="list-style-type: none"> <li>• Flexible</li> <li>• Synthetic</li> <li>• With upper seam and hanger</li> </ul>



	EINWEG	DISPOSABLE	
	<ul style="list-style-type: none"> <li>• Blau-transparent</li> <li>• Außen griffig</li> <li>• Spitze geschlossen</li> <li>• Für alle Massen geeignet</li> </ul>	<ul style="list-style-type: none"> <li>• Blue-transparent</li> <li>• Non-slip exterior</li> <li>• Closed tip</li> <li>• For all fillings</li> </ul>	- 20 / + 40 °C
	<ul style="list-style-type: none"> <li>• Grün-transparent</li> <li>• Spitze geschlossen</li> <li>• Für alle Massen geeignet</li> </ul>	<ul style="list-style-type: none"> <li>• Green-transparent</li> <li>• Closed tip</li> <li>• For all fillings</li> </ul>	- 20 / + 40 °C
	<ul style="list-style-type: none"> <li>• Biologisch abbaubar und kompostierbar</li> <li>• Hell-Beige</li> <li>• Nicht geeignet für sehr schwere oder dicken Massen</li> </ul>	<ul style="list-style-type: none"> <li>• Biodegradable and compostable</li> <li>• Off-white</li> <li>• Not suitable for very heavy or thick masses</li> </ul>	+ 5 / + 40 °C
	<ul style="list-style-type: none"> <li>• Orange-transparent</li> <li>• Außen extrem griffig</li> <li>• Spitze geschlossen</li> <li>• Für alle Massen geeignet – (speziell für schwere und warme Massen)</li> </ul>	<ul style="list-style-type: none"> <li>• Orange-transparent</li> <li>• Extreme non-slip exterior</li> <li>• Closed tip</li> <li>• For all fillings – (great for heavy consistencies and hot products)</li> </ul>	- 20 / + 70 °C
	<ul style="list-style-type: none"> <li>• Transparent</li> <li>• Spitze geschlossen</li> <li>• Für alle Massen geeignet</li> </ul>	<ul style="list-style-type: none"> <li>• Transparent</li> <li>• Closed tip</li> <li>• For all fillings</li> </ul>	- 20 / + 40 °C
	<ul style="list-style-type: none"> <li>• <b>Doppelspritzbeutel mit Trenneinlage</b></li> <li>• Transparent</li> <li>• Spitze geschlossen</li> <li>• Für zwei verschiedene Massen geeignet</li> </ul>	<ul style="list-style-type: none"> <li>• <b>Double-compartment pastry bag</b></li> <li>• Transparent</li> <li>• Closed tip</li> <li>• For two different fillings</li> </ul>	- 20 / + 40 °C
	<ul style="list-style-type: none"> <li>• <b>“Zipper”</b> zum Verschließen</li> <li>• Transparent</li> <li>• Mit Skala und Beschriftungsfeld</li> <li>• Spitze geschlossen</li> <li>• Für alle Massen geeignet</li> </ul>	<ul style="list-style-type: none"> <li>• With zip-lock</li> <li>• Transparent</li> <li>• With measurement guide and labelling field</li> <li>• Closed tip</li> <li>• For all fillings</li> </ul>	- 20 / + 40 °C



DE	SPRITZBEUTEL "EXPORT"	
EN	PASTRY BAGS "EXPORT"	
IT	SAC À POCHE "EXPORT"	
ES	MANGAS "EXPORT"	

- |  |   |
|--|---|
| <ul style="list-style-type: none"> <li>• Beschichtete Baumwolle</li> <li>• Lebensmittelecht</li> <li>• Verschweißte Längsnaht</li> <li>• Mehrmals verwendbar</li> <li>• Undurchlässig</li> </ul> | <ul style="list-style-type: none"> <li>• Coated cotton</li> <li>• Food safe</li> <li>• Welded seam</li> <li>• Useable several times</li> <li>• Impermeable</li> </ul> |
|--|---|

**Mit Saum und Tüllenverstärkung**

**With upper seam and reinforced tip**

#	Größe / size	↗ mm	
350080	0	250	
350081	1	280	
350082	2	340	
350083	3	400	
350084	4	460	
350085	5	500	
350086	6	550	
350087	7	600	
350088	8	650	
350089	9	700	
350090	10	750	



DE	SPRITZBEUTEL "STANDARD"	
EN	PASTRY BAGS "STANDARD"	
IT	SAC À POCHE "STANDARD"	
ES	MANGAS "STANDARD"	

- |  |   |
|--|---|
| <ul style="list-style-type: none"> <li>• Beschichtete Baumwolle</li> <li>• Lebensmittelecht</li> <li>• Verschweißte Längsnaht</li> <li>• Mehrmals verwendbar</li> <li>• Undurchlässig</li> </ul> | <ul style="list-style-type: none"> <li>• Coated cotton</li> <li>• Food safe</li> <li>• Welded seam</li> <li>• Useable several times</li> <li>• Impermeable</li> </ul> |
|--|---|

**Mit Saum und Tüllenverstärkung**

**With upper seam and reinforced tip**

#	Größe / size	↗ mm	
350170	0	250	
350171	1	280	
350172	2	340	
350173	3	400	
350174	4	460	
350175	5	500	
350176	6	550	
350177	7	600	
350178	8	650	
350179	9	700	
350180	10	750	

DE	SPRITZBEUTEL "MASTERFLEX"
EN	PASTRY BAGS "MASTERFLEX"
IT	SAC À POCHE "MASTERFLEX"
ES	MANGAS "MASTERFLEX"



- |  |  |
|--|--|
| <ul style="list-style-type: none"> <li>• Für höchste Ansprüche</li> <li>• 100 % lebensmittelecht</li> <li>• Längsnaht verschweißt</li> <li>• Mit Aufhänger</li> <li>• Innenseite glatt</li> <li>• Außenseite griffig</li> <li>• Flexibles Material (Polyurethan)</li> <li>• Undurchlässig</li> <li>• Auch für Mikrowelle geeignet</li> </ul> | <ul style="list-style-type: none"> <li>• For highest requirements</li> <li>• 100 % food safe</li> <li>• Welded seam</li> <li>• With hanging loop</li> <li>• Inner surface smooth</li> <li>• Outer surface grippy</li> <li>• Flexible material (Polyurethane)</li> <li>• Impermeable</li> <li>• Suitable for microwave</li> </ul> |
|--|--|

#	Größe / size	↗ mm
330002	2	340
330003	3	400
330004	4	460
330005	5	500
330007	7	600



DE	SPRITZBEUTEL "PREMIUM"
EN	PASTRY BAGS "PREMIUM"
IT	SAC À POCHE "PREMIUM"
ES	MANGAS "PREMIUM"



- |  |   |
|--|---|
| <ul style="list-style-type: none"> <li>• Synthetisches Gewebe, beschichtet</li> <li>• Lebensmittelecht</li> <li>• Mit Aufhänger</li> <li>• Mehrmals verwendbar</li> <li>• Undurchlässig</li> </ul> | <ul style="list-style-type: none"> <li>• Synthetic fabric, coated</li> <li>• Food safe</li> <li>• Including hanger</li> <li>• Useable several times</li> <li>• Impermeable</li> </ul> |
|--|---|

#	Größe / size	↗ mm
350250	0	250
350251	1	280
350252	2	340
350253	3	400
350254	4	460
350255	5	500
350256	6	550
350257	7	600
350258	8	650
350259	9	700
350260	10	750





DE	HAUSHALTS-SPRITZBEUTEL	
EN	PASTRY BAGS FOR DOMESTIC USE	
IT	SAC À POCHE – USO DOMESTICO	
ES	MANGAS – USO CASERO	

- |   |   |
|---|---|
| <ul style="list-style-type: none"> <li>• Beschichtete Baumwolle</li> <li>• Lebensmittelecht</li> <li>• Undurchlässig</li> <li>• Mehrmals verwendbar,</li> <li>• Ohne Saum und ohne Aufhänger</li> </ul> | <ul style="list-style-type: none"> <li>• Coated cotton</li> <li>• Food safe</li> <li>• Impermeable</li> <li>• Useable several times</li> <li>• Without seam and without hanger</li> </ul> |
|---|---|

Mit 2-teiligem Schraubadapter, 3 Sterntüllen, 1 Lochtülle, 1 Dekortülle und 1 Berlinertülle  
 With special adapter, 3 star tubes, 1 plain tube, 1 decoration tube and 1 fritter tube

#	Größe / size	↗ mm	
<input checked="" type="checkbox"/> 350144	1	280	
<input checked="" type="checkbox"/> 350145	1a	310	



DE	TÜLLEN-ADAPTER-SET
EN	EXTERNAL PIPING TUBE ADAPTER SET
IT	SET DI BOCCHETTE CON ADATTATORE
ES	JUEGO DE BOQUILLAS CON ADAPTADOR

- |   |  |
|---|--|
| Material: PP, weiß  | Made of PP, white  |
| <ul style="list-style-type: none"> <li>• 6-teilig</li> <li>• Schraubverschluss</li> </ul> | <ul style="list-style-type: none"> <li>• 6 pieces</li> <li>• With screw top</li> </ul> |

#		
350147	3 Sterntüllen, 1 Lochtülle, 1 Dekortülle, 1 Berliner Tülle / 3 star tubes, 1 plain tube, 1 decoration tube, 1 fritter tube	



DE	DEKOR-SPRITZBEUTEL	
EN	DECORATING BAG	
IT	SAC À POCHE PER DECORARE	
ES	MANGA PARA DECORAR	

- |   |  |
|---|--|
| <ul style="list-style-type: none"> <li>• Gewebe, beschichtet</li> <li>• Längsnaht verklebt, ganz geschlossen</li> <li>• Lebensmittelecht</li> <li>• Undurchlässig</li> <li>• Mehrmals verwendbar</li> </ul> | <ul style="list-style-type: none"> <li>• Fabrics, coated cotton</li> <li>• Glued seam, with closed tip</li> <li>• Food safe</li> <li>• Impermeable</li> <li>• Useable several times</li> </ul> |
|---|--|

#	↗ mm	
350650	210	1 Beutel = 5 Stk. / 1 bag = 5 pcs.



DE	DEKOR-SPRITZBEUTEL "PERGAMYN"
EN	DECORATING BAGS "PERGAMYN"
IT	SACCHETTI PER DECORARE "PERGAMINA"
ES	MANGAS PARA DECORAR "PERGAMINO"

- |  |  |
|--|--|
| Material: Pergamyn   | Made of pergamyn   |
| <ul style="list-style-type: none"> <li>• Mit oder ohne Tülle verwendbar</li> </ul> | <ul style="list-style-type: none"> <li>• Useable with or without tube</li> </ul> |

#	↗ mm	
350600	210	1000 Stk. / pcs.
350601	370	1000 Stk. / pcs.

DE	SPRITZBEUTEL-WANDAUFHÄNGER
EN	WALL RACKS FOR PASTRY BAGS
IT	SUPPORTI PER SAC À POCHE E BOCCHETTE
ES	COLGADORES DE MANGAS Y BOQUILLAS

- |   |  |
|---|--|
| <ul style="list-style-type: none"> <li>• Sehr stabile Ausführung</li> <li>• Verpackt im Einzelkarton</li> <li>• Für 4 Spritzbeutel und 31 Tüllen maximal verwendbar</li> <li>• Inkl. Kleingeräteablage und 5 Haken</li> </ul> | <ul style="list-style-type: none"> <li>• Sturdy</li> <li>• Single packing</li> <li>• For 4 pastry bags and 31 piping tubes</li> <li>• With rack for depositing small tools with 5 hooks</li> </ul> |
|---|--|

#		↔ mm	
157000	weiß beschichtet / coated in white plastic	500 x 500	
157001	Edelstahl / made of stainless steel	500 x 500	

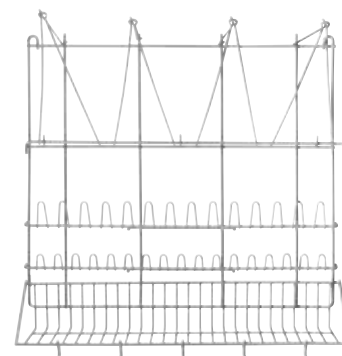

#157001

DE	SPRITZBEUTEL-ABSETZSTÄNDER
EN	SUPPORT FOR PASTRY BAGS
IT	SUPPORTO PER SAC À POCHE
ES	SOPORTE PARA MANGAS

- |   |   |
|---|---|
| <p>Material: PP, Farbe elfenbein</p> <ul style="list-style-type: none"> <li>• Stabil</li> <li>• Mit 8 Aussparungen für 4 große und 4 kleine Spritztüllen</li> </ul> | <p>Made of PP, ivory</p> <ul style="list-style-type: none"> <li>• Sturdy</li> <li>• With holes for 4 large and 4 small tubes</li> </ul> |
|---|---|

#	↓ Ø mm	↑ mm	
157002	195	230	



10

DE	VERSCHLUSS-CLIP
EN	FASTENING CLIPS
IT	CLIP DI CHIUSURA
ES	CLIPS CIERRA BOLSAS

- |  |   |
|--|---|
| <p>Material: PP</p> <ul style="list-style-type: none"> <li>• Zum dichten Verschließen von Spritzbeuteln und Vorratsbeuteln</li> <li>• Spülmaschinenfest</li> </ul> | <p>Made of PP</p> <ul style="list-style-type: none"> <li>• For closing of pastry bags and other bags</li> <li>• Dishwasher proof</li> </ul> |
|--|---|

#	↗ mm			
<input checked="" type="checkbox"/> 391900	 125	mit Messer / including blade	6	
<input checked="" type="checkbox"/> 391901	 175	ohne Messer / without knife	6	
<input checked="" type="checkbox"/> 391902	 285	mit abnehmbarem Griff / with twist-on handle	4	

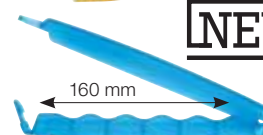
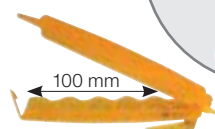

**NEW**



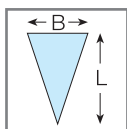

DE	EINWEG-SPRITZBEUTEL – GEROLLT
EN	DISPOSABLE PASTRY BAGS – ROLLED
IT	SAC A POCHE USA E GETTA – ARROTOLATO
ES	MANGAS PASTELERAS DESECHABLES – ENROLLADAS

Material: PE, **mehrfach extrudiert**

- Blau-transparent, hygienisch
  - Glatte Innenseite
  - Mit Abreiperforation
  - Hohe Reißfestigkeit der Schweißnaht
  - Spitze geschlossen mit / ohne Tlle verwendbar
  - Karton mit Entnahmeffnung
- 100 Stk. / Box**

Material: PE, **multiple layers**

- Blue-transparent, hygienic
  - Smooth inside
  - With tear-off perforation
  - High tensile strength of the weld seam
  - Tip closed usable with / without tube
  - Carton with removal opening
- 100 pcs. / Box**

#	↗ mm	→ mm	μ	
391200	350	195	75	
391210	470	230	75	
391220	530	275	75	
391230	600	300	75	
391240	300	160	75	

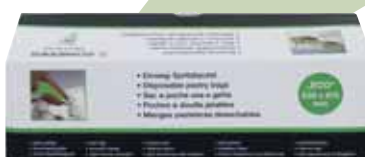
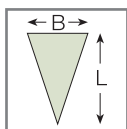

DE	EINWEG-SPRITZBEUTEL – GEROLLT „ECO“
EN	DISPOSABLE PASTRY BAGS – ROLLED „ECO“
IT	SAC A POCHE USA E GETTA – ARROTOLATO „ECO“
ES	MANGAS PASTELERAS DESECHABLES – ENROLLADAS „ECO“

Material: PE, **dreifach extrudiert**

- Grn-transparent, hygienisch
  - Glatte Innenseite
  - Mit Abreiperforation
  - Hohe Reißfestigkeit der Schweißnaht
  - Spitze geschlossen mit / ohne Tlle verwendbar
  - Karton mit Entnahmeffnung
- 100 Stk. / Box**

Material: PE, **3-layers**

- Green-transparent, hygienic
  - Smooth inside
  - With tear-off perforation
  - High tensile strength of the weld seam
  - Tip closed usable with / without tube
  - Carton with removal opening
- 100 pcs. / Box**

#	↗ mm	→ mm	μ	
391800	350	195	70	
391810	470	230	70	
391820	530	275	70	

DE	EINWEG-SPRITZBEUTEL – GEROLLT
EN	DISPOSABLE PASTRY BAGS – ROLLED
IT	SAC A POCHE USA E GETTA – ARROTOLATO
ES	MANGAS PASTELERAS DESECHABLES – ENROLLADAS

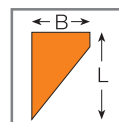

- Material: PE, **dreifach extrudiert**
- Orange, hygienisch
  - Extrem griffig
  - Glatte Innenseite
  - Mit Abreißperforation
  - Auch mit nassen / fettigen Händen einsetzbar
  - Für alle Massen (warm, kalt, fest) geeignet
  - Mikrowellentauglich
  - Hohe Reißfestigkeit der Schweißnaht
  - Spitze geschlossen mit / ohne Tülle verwendbar
  - Karton mit Entnahmeöffnung
- 100 Stk. / Box**

- Material: PE, **3-layers**
- Orange, hygienic
  - Extremely grippy
  - Smooth inside
  - With tear-off perforation
  - Also usable with wet / greasy hands
  - Suitable for all masses (warm, cold, solid)
  - Microwaveable
  - High tensile strength of the weld seam
  - Tip closed usable with / without tube
  - Carton with removal opening
- 100 pcs. / Box**



#	↗ mm	→ mm	μ
391320	530	280	80
391330	590	280	80

DE	EINWEG-SPRITZBEUTEL – GEROLLT „KOMPOSTIERBAR“
EN	DISPOSABLE PASTRY BAGS – ROLLED “COMPOSTABLE”
IT	SAC A POCHE USA E GETTA – ARROTOLATO “COMPOSTABILE”
ES	MANGAS PASTELERAS DESECHABLES – ENROLLADAS “COMPOSTABLE”

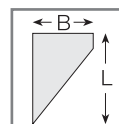

10

- Hergestellt aus biologisch abbaubaren und kompostierbaren Rohstoffen gemäß EN13432 (industrielle Kompostierbarkeit)
  - Haltbarkeit: 18 Monate ab Produktionsdatum
  - Farbe: Hell-Beige
  - Glatte innere Beutelschicht für optimalen Durchfluss
  - Nicht geeignet für sehr schwere oder dicken Massen
  - Sterile Beutelinnenseite
  - Hohe Reiß- und Durchstoßfestigkeit
  - Karton mit Entnahmeöffnung
- 72 Stk. / Box**

- Made from biodegradable and compostable raw materials according to EN13432 (industrial compostability).
  - Shelf-Life 18 month from production date
  - Color: off-white, cream-colored appearance
  - Smooth inner bag layer to allow for optimal flow
  - Not suitable for very heavy or thick masses
  - Sterile bag interior
  - High tear and puncture resistance
  - Carton with removal opening
- 72 pcs. / Box**



#	↗ mm	→ mm	μ
391920	530	280	100





DE	EINWEG-SPRITZBEUTEL – DOPPELT
EN	DISPOSABLE PASTRY BAGS – DOUBLE
IT	SAC A POCHE USA E GETTA – DOPPIO
ES	MANGAS PASTELERAS DESECHABLES – DOBLE

**Doppelspritzbeutel mit Trenneinlage für zwei verschiedene Massen.**

Material: PE, **doppelt extrudiert.**

- Innenseite glatt
- Gebündelt
- Transparent
- Hygienisch
- Spitze geschlossen
- Ohne Tülle verwendbar
- Hohe Reißfestigkeit der Schweißnaht
- Karton mit Dispenseröffnung

**75 Stk. / Box**

**Double compartment pastry bag with a partition down in the middle, best for using two different ingredients.**

Made of PE, **multiple layers.**

- Silky inner surface for maximum product flow
- Bundle
- Transparent
- Hygienic
- Closed tip
- Can be used without tube for decorating purposes

- Seam with high tensile strength
- Dispenser box

**75 pcs. / Box**

#	↗ mm	→ mm	μ	
<input checked="" type="checkbox"/> 391850	455	305	70	

**i** Passender Adapter + Tüllen auf Seite 221 ff. / Piping tube adapter + decoration tubes on page 221 ff.



DE	EINWEG-SPRITZBEUTEL – “ZIPPER”
EN	DISPOSABLE PASTRY BAGS – “ZIPPER”
IT	SAC A POCHE USA E GETTA – “ZIPPER”
ES	MANGAS PASTELERAS DESECHABLES – “ZIPPER”

Material: CPE

- Hochtransparent
- Mit Skala
- Beschriftungsfeld und Zipper
- Zum Verschließen

**50 Stk. / Box**

Made of CPE

- Crystal clear
- Graduated
- With zip-lock and labelling field
- For locking

**50 pcs. / Box**

#	↗ mm	→ mm	μ	
391050	320	150	50	

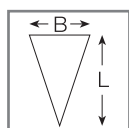

DE	EINWEG-SPRITZBEUTEL – GEBÜNDELT
EN	DISPOSABLE PASTRY BAGS – BUNDLED
IT	SAC A POCHE USA E GETTA – IN BUNDLE
ES	MANGAS PASTELERAS DESECHABLES – EN PAQUETE

Material: PE, **dreifach extrudiert**

- Transparent, hygienisch
- Glatte Innenseite
- Mit Abreißperforation
- Hohe Reißfestigkeit der Schweißnaht
- Spitze geschlossen mit / ohne Tülle verwendbar
- Karton mit Dispenseröffnung

**100 Stk. / Box**

Material: PE, **3-layers**

- Transparent, hygienic
- Smooth inside
- With tear-off perforation
- High tensile strength of the weld seam
- Tip closed usable with / without tube
- Carton with dispenser opening

**100 pcs. / Box**



#	↗ mm	→ mm	μ	
<input checked="" type="checkbox"/> 391400	350	240	75	
<input checked="" type="checkbox"/> 391410	545	300	75	

DE	EINWEG-SPRITZBEUTEL-SET
EN	SET OF DISPOSABLE PASTRY BAGS
IT	SET SAC A POCHE USA E GETTA
ES	JUEGO DE MANGAS DESECHABLES

Set bestehend aus:

- 10 Einweg-Spritzbeuteln (Länge 340 mm),
- 1 Lochtülle, 1 Sternbandtülle, 2 Sterntüllen,
- 1 Verschlussstülle und 1 Verschlussclip
- 10 cm mit Schneidemesser
- Einwegspritzbeutel PE
- Tüllen und Clip aus PP

Set of:

- 10 disposable bags (length 340 mm),
- 1 plain tube, 1 star ribbon tube, 2 star tubes, 1 tube fastener, 1 clip 10 cm length with integrated blade
- Pastry bags made of PE
- Tubes and clip made of PP



#		
<input checked="" type="checkbox"/> 350199		



DE	WANDHALTERUNG FÜR EINWEGSPRITZBEUTEL
EN	WALL HOLDER FOR DISPOSABLE PASTRY BAGS
IT	SUPPORTO A PARETE PER SAC À POCHE USA E GETTA
ES	SOPORTE DE PARED PARA MANGAS DESECHABLES

Material: Edelstahl

- Karton mit 100 gerollten Einwegspritzbeuteln (blaue, grüne und orangene Qualitäten) wird seitlich eingeführt
- Größen: 350 mm – 600 mm
- Rückseitige Löcher für Wandmontage
- Schrauben und Dübel sind nicht im Lieferumfang enthalten

Made of stainless steel

- Carton with 100 rolled disposable pastry bags (blue, green and orange designs) to be inserted sideways
- Sizes: 350 mm – 600 mm
- Holes on the back for wall mounting
- Screws and dowels are not included

#	↗ mm	→ mm	↑ mm	
399000	320	115	110	



10



DE	STERNTÜLLEN
EN	STAR TUBES
IT	BOCCHETTE FORO STELLA, IN UNIPEZZO, INOX
ES	BOQUILLAS ESTRELLA, SIN SOLDADURA

Material: Edelstahl

Made of stainless steel

• Aus einem Stück gezogen

• In one piece



#	Ø mm	Zähne / teeth
197550	2	6
197551	3	6
197552	4	6
197553	5	6
197554	6	6
197555	7	6
197556	8	6
197557	9	6
197558	10	7
197559	11	7
197560	12	7
197561	13	7
197562	14	8
197563	15	8
197564	16	9
197565	17	10
197566	18	10



DE	STERNTÜLLEN-SATZ
EN	SET OF STAR TUBES
IT	SET DI BOCCHETTE FORO STELLA, IN UNIPEZZO, INOX
ES	JUEGO DE BOQUILLAS ESTRELLA, SIN SOLDADURA

Material: Edelstahl

Made of stainless steel

• Aus einem Stück gezogen

• In one piece

#	Ø mm
<input checked="" type="checkbox"/> 197136	Satz 10-teilig / set 10 pcs. – 4, 5, 6, 7, 8, 9, 10, 12, 13, 15



DE	LOCHTÜLLEN
EN	PLAIN TUBES
IT	BOCCHETTE FORO TONDO, IN UNIPEZZO, INOX
ES	BOQUILLAS LISAS, SIN SOLDADURA

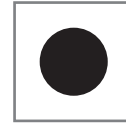

Material: Edelstahl

Made of stainless steel

• Aus einem Stück gezogen

• In one piece

#	Ø mm
197500	2
197501	3
197502	4
197503	5
197504	6
197505	7
197506	8
197507	9
197508	10
197509	11
197510	12
197511	13
197512	14
197513	15
197514	16
197515	17
197516	18
197517	20
197518	22
197519	24



10

DE	LOCHTÜLLEN-SATZ
EN	SET OF PLAIN TUBES
IT	SET DI BOCCHETTE FORO TONDO, IN UNIPEZZO, INOX
ES	JUEGO DE BOQUILLAS LISAS, SIN SOLDADURA



Material: Edelstahl

Made of stainless steel

• Aus einem Stück gezogen

• In one piece

#	Ø mm
<input checked="" type="checkbox"/> 197180	Satz 10-teilig / set 10 pcs. – 4, 5, 6, 7, 8, 9, 10, 12, 13, 15





DE	STERNTÜLLEN (FRANZÖSISCHE TÜLLEN)
EN	FRENCH STAR TUBES
IT	BOCCHETTE STELLA FRANCESE, IN UNIPEZZO, INOX
ES	BOQUILLAS ESTRELLA FRANCESA, SIN SOLDADURA

Material: Edelstahl

Made of stainless steel

• Aus einem Stück gezogen

• In one piece



#	Ø mm	Zähne / teeth
197335	4	9
197310	5	9
197311	6	9
197312	7	10
197313	8	12
197336	9	12
197314	10	14
197333	11	14
197315	12	15
197316	13	15
197317	14	16
197337	15	15
197318	16	17
197319	18	18

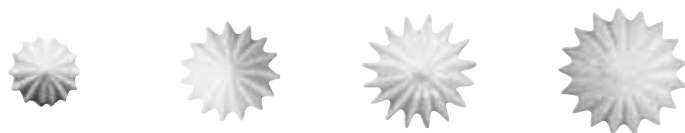

DE	STERNTÜLLEN, GESCHLOSSEN
EN	CLOSED STAR TUBES
IT	BOCCHETTE STELLA CHIUSA, IN UNIPEZZO, INOX
ES	BOQUILLAS ESTRELLA CERRADA, SIN SOLDADURA

Material: Edelstahl

Made of stainless steel

• Aus einem Stück gezogen

• In one piece



#	Ø mm	Zähne / teeth
197320	2	6
197321	3	6
197322	4	6
197323	5	6
197324	6	6
197325	7	6
197326	8	7
197327	9	7
197328	10	8
197329	11	9
197334	12	10



DE	STERNBANDTÜLLEN
EN	STAR RIBBON TUBES
IT	BOCCHETTE DELIZIA, IN UNIPEZZO, INOX
ES	BOQUILLAS "CINTA ESTRIADA", SIN SOLDADURA

Material: Edelstahl

Made of stainless steel

• Aus einem Stück gezogen

• In one piece

#	Öffnungsgröße / opening size (mm)
197300	16 x 2
197301	20 x 3
197302	28 x 4



DE	ROSENTÜLLEN
EN	ROSE TUBES
IT	BOCCHETTE "ROSA", IN UNIPEZZO, INOX
ES	BOQUILLAS "ROSA", SIN SOLDADURA

Material: Edelstahl

Made of stainless steel

• Aus einem Stück gezogen

• In one piece

#	Ø mm
197330	5
197331	6
197332	8



10

DE	BERLINER TÜLLE
EN	FRITTER TUBE
IT	BOCCHETTA AD IMBUTINO
ES	BOQUILLA ESPECIAL PARA RELLENAR

Material: Edelstahl

Made of stainless steel

• Verschweißt

• Welded seam

#	↑ mm	Ø mm
197340	95	4





DE	VERGISSMEINNICHT
EN	FORGET-ME-NOT
IT	NONTISCORDARDIMÉ
ES	NOMEOLVIDES

#	197400
Ø mm	4,5
↑ mm	39



DE	ROSENAUSDREHER
EN	ROSE SCREW
IT	ROSA OBLIQUA
ES	ROSA INCLINADA

#	197401
Ø mm	6,0
↑ mm	41



DE	LOCH
EN	HOLE
IT	FORO
ES	AGUJERO

#	197402
Ø mm	5,0
↑ mm	48



DE	BLÜTENBLATT KLEIN
EN	PETAL SMALL
IT	PETALO PICCOLO
ES	PÉTALO PEQUEÑO

#	197405
↔ mm	3,6 x 16
↑ mm	41



DE	BLÜTENBLATT MITTEL
EN	PETAL MEDIUM
IT	PETALO MEDIO
ES	PÉTALO MEDIO

#	197406
↔ mm	5,4 x 25
↑ mm	44



DE	BLÜTENBLATT GROSS
EN	PETAL LARGE
IT	PETALO GRANDE
ES	PÉTALO GRANDE

#	197407
↔ mm	3 x 15
↑ mm	53



DE	BLATTTÜLLE MINI
EN	LEAF MINI
IT	FOGLIO MINI
ES	HOJA MINI

#	197408
Ø mm	2,7
↑ mm	41



DE	BLATTTÜLLE MITTEL
EN	LEAF MEDIUM
IT	FOGLIO MEDIO
ES	HOJA MEDIA

#	197410
Ø mm	4,8
↑ mm	42



DE	BLATTTÜLLE GROSS
EN	LEAF LARGE
IT	FOGLIO GRANDE
ES	HOJA GRANDE

#	197411
Ø mm	4,6
↑ mm	52



DE	GARNIERTÜLLE
EN	GARNISHING TUBE
IT	BOCCHETTA DECORATRICE
ES	BOQUILLA PARA DECORACIÓN

#	197412
Ø mm	2,4
↑ mm	52



DE	GARNIERTÜLLE
EN	GARNISHING TUBE
IT	BOCCHETTA DECORATRICE
ES	BOQUILLA PARA DECORACIÓN

#	197413
Ø mm	6,0
↑ mm	47



DE	GARNIERTÜLLE
EN	GARNISHING TUBE
IT	BOCCHETTA DECORATRICE
ES	BOQUILLA PARA DECORACIÓN

#	197414
Ø mm	1,5
↑ mm	47



DE	GARNIERTÜLLE
EN	GARNISHING TUBE
IT	BOCCHETTA DECORATRICE
ES	BOQUILLA PARA DECORACIÓN

#	197415
Ø mm	6,0
↑ mm	52



DE	GARNIERTÜLLE
EN	GARNISHING TUBE
IT	BOCCHETTA DECORATRICE
ES	BOQUILLA PARA DECORACIÓN

#	197417
Ø mm	9,3
↑ mm	52



DE	STERNBANDTÜLLE OFFEN
EN	STAR RIBBON TUBE OPEN
IT	BOCCHETTA DELIZIA APERTA
ES	BOQUILLA CINTA ESTRIADA ABIERTA

#	197418
↔ mm	3,75 x 18
↑ mm	51,5



DE	DREILOCHTÜLLE
EN	THREE HOLES TUBE
IT	BOCCHETTA A TRE FORI
ES	BOQUILLAS CON TRES HOYOS

#	197420
Ø mm	3,0
↑ mm	50



DE	VERMICELLE KLEIN
EN	BIRD NEST TUBE SMALL
IT	VERMICELLI, PICCOLA
ES	VERMICELLI, PEQUEÑA

#	197421
Ø mm	1,0
↑ mm	38



DE	VERMICELLE GROSS
EN	BIRD NEST TUBE LARGE
IT	VERMICELLI, GRANDE
ES	VERMICELLI, GRANDE

#	197422
Ø mm	2,9
↑ mm	37



DE	VERMICELLE KLEIN
EN	BIRD NEST TUBE SMALL
IT	VERMICELLI, PICCOLA
ES	VERMICELLI, PEQUEÑA

#	197423
Ø mm	2,0
↑ mm	45



DE	VERMICELLE GROSS
EN	BIRD NEST TUBE LARGE
IT	VERMICELLI, GRANDE
ES	VERMICELLI, GRANDE

#	197424
Ø mm	4,5
↑ mm	45



DE	ST. HONORÉ
EN	ST. HONORÉ
IT	ST. HONORÉ
ES	ST. HONORÉ

#	197425
Ø mm	12
↑ mm	41



DE	ST. HONORÉ
EN	ST. HONORÉ
IT	ST. HONORÉ
ES	ST. HONORÉ

#	197426
Ø mm	14
↑ mm	39



DE	ST. HONORÉ
EN	ST. HONORÉ
IT	ST. HONORÉ
ES	ST. HONORÉ

#	197427
Ø mm	15
↑ mm	46



DE	ST. HONORÉ
EN	ST. HONORÉ
IT	ST. HONORÉ
ES	ST. HONORÉ

#	197403
↔ mm	11 x 21
↑ mm	53



DE	GARNIERTÜLLE
EN	GARNISHING TUBE
IT	BOCCHETTA DECORATRICE
ES	BOQUILLA PARA DECORACIÓN

#	197428
Ø mm	11
↑ mm	51



DE	GARNIERTÜLLE
EN	GARNISHING TUBE
IT	BOCCHETTA DECORATRICE
ES	BOQUILLA PARA DECORACIÓN

#	197429
Ø mm	13
↑ mm	48



DE	GARNIERTÜLLE
EN	GARNISHING TUBE
IT	BOCCHETTA DECORATRICE
ES	BOQUILLA PARA DECORACIÓN

#	197430
Ø mm	15
↑ mm	52



DE	STERNBANDTÜLLE
EN	STAR RIBBON TUBE
IT	BOCCHETTA DELIZIA
ES	BOQUILLA PARA DECORACIÓN

#	197303
Ø mm	19
↑ mm	52



DE	MAGNOLIE
EN	MAGNOLIA
IT	MAGNOLIA
ES	MAGNOLIA

#	197570
Ø mm	25
↑ mm	42



DE	TULPE
EN	TULIP
IT	TULIPANO
ES	TULIPÁN

#	197571
Ø mm	23
↑ mm	42



DE	ROSE
EN	ROSE
IT	ROSA
ES	ROSA

#	197572
Ø mm	25
↑ mm	42



DE	TULPE
EN	TULIP
IT	TULIPANO
ES	TULIPÁN

#	197573
Ø mm	23
↑ mm	42



DE	NARZISSE
EN	DAFFODIL
IT	NARCISO
ES	NARCISO

#	197574
Ø mm	25
↑ mm	42



DE	TULPE
EN	TULIP
IT	TULIPANO
ES	TULIPÁN

#	197575
Ø mm	25
↑ mm	42



DE	TULPE
EN	TULIP
IT	TULIPANO
ES	TULIPÁN

#	197576
Ø mm	25
↑ mm	42



DE	TULPE
EN	TULIP
IT	TULIPANO
ES	TULIPÁN

#	197577
Ø mm	25
↑ mm	42



DE	BLÜMCHEN
EN	FLOWER
IT	FIORELLINO
ES	FLORCITA

#	197578
Ø mm	25
↑ mm	42



DE	BLÜMCHEN
EN	FLOWER
IT	FIORELLINO
ES	FLORCITA

#	197579
Ø mm	25
↑ mm	42



DE	BLÜMCHEN
EN	FLOWER
IT	FIORELLINO
ES	FLORCITA

#	197580
Ø mm	25
↑ mm	42



DE	BLÜMCHEN
EN	FLOWER
IT	FIORELLINO
ES	FLORCITA

#	197581
Ø mm	25
↑ mm	42



DE	BLÜMCHEN
EN	FLOWER
IT	FIORELLINO
ES	FLORCITA

#	197582
Ø mm	25
↑ mm	42



DE	BLÜMCHEN
EN	FLOWER
IT	FIORELLINO
ES	FLORCITA

#	197583
Ø mm	25
↑ mm	42



DE	BLÜMCHEN
EN	FLOWER
IT	FIORELLINO
ES	FLORCITA

#	197584
Ø mm	25
↑ mm	42

DE	SPRITZTÜLLEN-SET
EN	SET OF DECORATING TUBES
IT	SET BOCCHETTE, INOX
ES	CAJA SURTIDA DE BOQUILLAS

- |                               |                              |
|-------------------------------|------------------------------|
| Material: Edelstahl           | Made of stainless steel      |
| • Inklusive Adapter           | • With adapter               |
| • Box aus stabilem Kunststoff | • Box made of sturdy plastic |

#	Teile / pieces	↑ mm
197032	55	30
197033	29	30
197060	38	50



DE	TÜLLENBÜRSTE
EN	BRUSH FOR TUBES
IT	BRUSCHINO PER BOCCHETTE
ES	CEPILLO PARA LIMPIAR BOQUILLAS

- |                                 |                              |
|---------------------------------|------------------------------|
| • Griff aus PP, mit Aufhängeöse | • Grip made of PP, with hole |
| • Borsten aus Nylon             | • Bristles made of nylon     |
| • Für alle Tüllen verwendbar    | • Useable for all tubes      |

#	↗ mm
200245	180



10

DE	TÜLLEN-ADAPTER
EN	EXTERNAL PIPING TUBE ADAPTER
IT	ADATTATORE PER BOCCHETTE
ES	ADAPTADOR PARA BOQUILLAS

- |                     |                  |
|---------------------|------------------|
| Material: PP, weiß  | PP, white        |
| • 2-teilig          | • 2 pieces       |
| • Schraubverschluss | • With screw top |

#	↑ mm
197595	77



**Bsp.: Für nahezu alle Tüllen verwendbar! Can be used for nearly all nozzles!**





DE	TÜLLEN-ADAPTER - <b>DOPPELT</b>		
EN	EXTERNAL PIPING TUBE ADAPTER - <b>DOUBLE</b>		
IT	ADATTATORE PER BOCCHETTE - <b>DOPPIO</b>		
ES	ADAPTADOR PARA BOQUILLAS - <b>DOBLE</b>		

- Material: BPA-frei, Farbe glasklar
- 3-teilig
  - Spülmaschinengeeignet
  - Für Einwegspritzbeutel 50 µ bis 75 µ

- BPA-free, color: crystal clear
- 3 pieces
  - Dishwasher safe
  - For disposable pastry bags 50 µ to 75 µ

#	Ø mm	↑ mm	
<input checked="" type="checkbox"/> 196660	48	63	

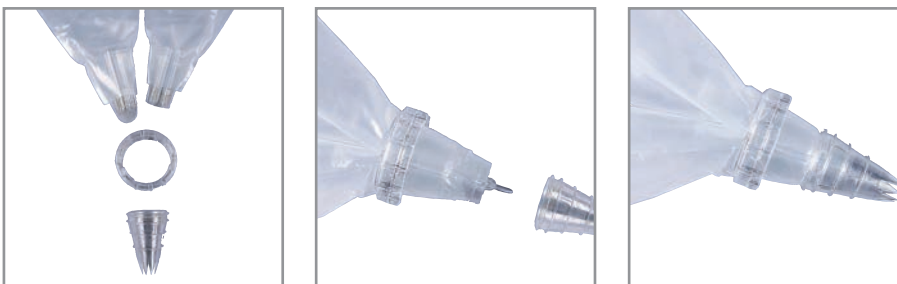

**i** Mit allen "Multi-Deko"-Tüllen verwendbar. / Can be used with all "Multi-Deko" tubes. / Utilizzabile con tutte le bocchette "Multi-Deko". / Se puede usar con todas las boquillas "Multi-Deko".



Adapter mit Tülle zum Aufstecken / twist-on adapter

DE	TÜLLENKASSETTEN-SET "MULTI-DEKO"		
EN	INTERCHANGABLE PIPING TUBES SET "MULTI-DEKO"		
IT	SET BOCCHETTE ASSORTITE "MULTI-DEKO"		
ES	SURTIDO BOQUILLAS "MULTI-DEKO"		

- Material: PCTG – BPA-frei, Farbe glasklar
- Wandmontage möglich
  - Inkl. Deckel für hygienische Aufbewahrung
  - Spülmaschinengeeignet

- Made of PCTG – BPA-free, color: crystal clear
- Wall fastening possible
  - Incl. lid for hygienic storage
  - Dishwasher safe

#		Ø mm	
<input checked="" type="checkbox"/> 196600	8 Lochtüllen, 2 Adapter, 2 Verschlüsse, 1 Tüllenbürste / 8 plain tubes, 2 adapters, 2 caps, 1 brush	1, 2, 3, 5, 7, 9, 13, 15	
<input checked="" type="checkbox"/> 196610	8 Sterntüllen, 2 Adapter, 2 Verschlüsse, 1 Tüllenbürste / 8 star tubes, 2 adapters, 2 caps, 1 brush	4, 5, 7, 9 (6 Zähne/points) 7, 9, 11, 13 (8 Zähne/points)	
<input checked="" type="checkbox"/> 196620	8 Dekortüllen, 1 Berliner Tülle, 2 Adapter, 2 Verschlüsse / 8 decorating tubes, 1 fritter tube, 2 adapters, 2 caps		
<input checked="" type="checkbox"/> 196630	8 franz. Sterntüllen, 2 Adapter, 2 Verschlüsse, 1 Tüllenbürste / 8 french star tubes, 2 adapters, 2 caps, 1 brush	4,5 / 5,5 / 6 / 7,5 / 8 / 8 / 9 / 10	



Adapter mit Verschluss-Kappe / adapter with cap



**i** scharfe Konturen für perfektes Dekorieren / sharp contours for perfect decorating



# 196600



# 196610

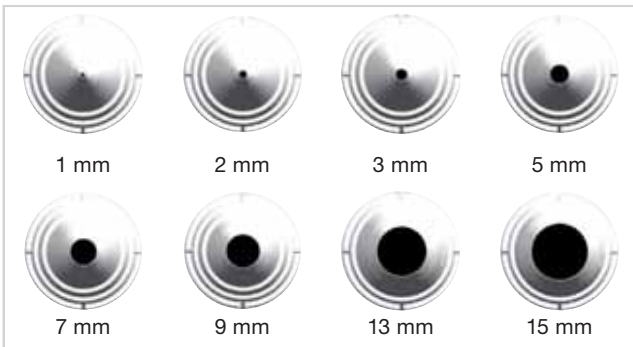

# 196620



# 196630



10





DE	STERNTÜLLEN
EN	STAR TUBES
IT	BOCCHETTE FORO STELLA
ES	BOQUILLAS ESTRELLA

Material: PP, Farbe elfenbein  
 • Höhe: 6 cm

Made of PP, color ivory  
 • Height: 6 cm



#	Ø mm
196500	3
196501	5
196502	7
196503	9
196504	11
196505	13
196506	15
196507	17



DE	LOCHTÜLLEN
EN	PLAIN TUBES
IT	BOCCHETTE FORO TONDO
ES	BOQUILLAS LISAS

Material: PP, Farbe elfenbein  
 • Höhe: 6 cm

Made of PP, color ivory  
 • Height: 6 cm



#	Ø mm
196520	5
196521	7
196522	9
196523	11
196524	13
196525	15
196526	17
196527	19
196528	26

# 196530



DE	TÜLLEN-SET
EN	PIPING TUBE SET
IT	SET DI BOCCHETTE
ES	JUEGO DE BOQUILLAS

Material: PP, Farbe elfenbein  
 • Höhe: 6 cm  
 • 6 verschiedene Tüllen

Made of PP, color ivory  
 • Height: 6 cm  
 • 6 different tubes

# 196540



#	Ø mm
196530	3, 5, 7, 9, 11, 13
196540	5, 7, 9, 11, 13, 15

DE	TÜLLENKASSETTEN-SET
EN	ASSORTED PIPING TUBE SET
IT	SCATOLA DI BOCCHETTE ASSORTITE
ES	CAJA DE BOQUILLAS SURTIDAS

Material: PP, Farbe elfenbein

• Höhe: 6 cm

• **12 verschiedene Tüllen**

Made of PP, color ivory

• Height: 6 cm

• **12 different tubes**

#		Ø (ca. mm)	
196550	4 Sterntüllen, 4 Lochtüllen, 4 Garniertüllen / 4 star tubes, 4 plain tubes, 4 decorating tubes	5, 7, 9, 11 5, 7, 9, 11 Grattülle, Rosentülle, Stern- bandtülle links und rechts / ribbon, rose, star ribbon tip, left and right	
196560	4 Sterntüllen, 4 Lochtüllen, 4 Garniertüllen / 4 star tubes, 4 plain tubes, 4 decorating tubes	11, 13, 15, 17 13, 15, 17, 19 Blatt-, Doppelloch-, Rosen- und Riefentülle / Leaf, double hole, rose and flute tip	

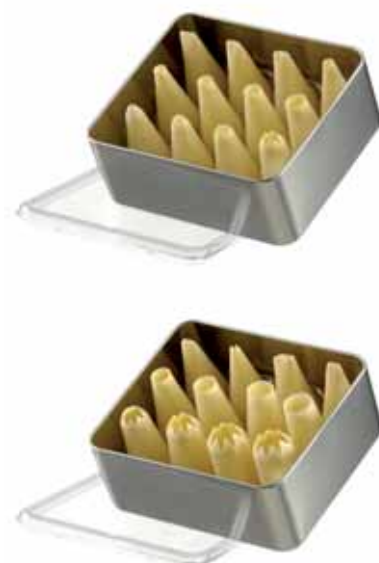

Material: PP, Farbe elfenbein

• Höhe: ca. 3,0 – 3,5 cm

• **20 verschiedene Tüllen**

• **2 Adapter (2-tlg.)**

Made of PP, color ivory

• Height: 3.0 – 3.5 cm

• **20 different tubes**

• **2 adapters (2 pcs.)**

#		Ø (ca. mm)	
196570	4 Sterntüllen, 8 Lochtüllen, 8 Garniertüllen, 2 Adapter (2-tlg.) / 4 star tubes, 8 plain tubes, 8 decorating tubes, 2 adapters (2 pcs.)	5, 7, 11, 13 5 – 13	
196580	8 Sterntüllen, 4 Lochtüllen, 8 Garniertüllen, 2 Adapter (2-tlg.) / 8 star tubes, 4 plain tubes, 8 decorating tubes, 2 adapters (2 pcs.)	3 – 17 5, 7, 9, 13	



10



© stockcreative / stock.adobe.com



DE	EISSPACHTEL	
EN	ICE CREAM SPATULA	
IT	SPATOLA PER GELATO	
ES	ESPÁTULA PARA HELADO	

#		↗ mm	→ mm	↑ mm
195100	●	260	65	15
195110	●	300	65	15
195120	●	260	65	15
195130	●	300	65	15
195140	●	260	65	15
195150	●	300	65	15
195180	●	260	65	15
195190	●	300	65	15



DE	EISSPACHTEL	
EN	ICE CREAM SPATULA	
IT	SPATOLA PER GELATO	
ES	ESPÁTULA PARA HELADO	

#		↗ mm	→ mm	↑ mm
195210	●	260	65	15
195220	●	260	65	15
195230	●	260	65	15
195250	●	260	65	15
195260	○	260	65	15



DE	EISSPACHTEL	
EN	ICE CREAM SPATULA	
IT	SPATOLA PER GELATO	
ES	ESPÁTULA PARA HELADO	

#		↗ mm	→ mm	↑ mm
195290	○	270	65	15

DE	EISDIPPER	
EN	ICE CREAM DIPPERS	ALU
IT	SPATOLE PER GELATO	
ES	RACIONADORES HELADO COMPACTOS	

Material: Aluminium, wärmeleitende Flüssigkeit im Griff

Made of aluminum, with heat conductive fluid inside handle

#		Ø mm
<input checked="" type="checkbox"/> 190210	1/16	61
<input checked="" type="checkbox"/> 190220	1/20	57
<input checked="" type="checkbox"/> 190230	1/24	51
<input checked="" type="checkbox"/> 190240	1/30	45



DE	EISPORTIONIERER	
EN	ICE CREAM SCOOPS	CNS
IT	PORZIONATORI PER GELATO	
ES	RACIONADORES HELADO	

**Material: Edelstahl**

- Ergonomischer Griff aus Kunststoff
- Anwendung: für Eis, Früchte, Reis, Mousse und andere Speisen

**Made of stainless steel**

- With ergonomic plastic handle
- Usable for ice cream, fruits, rice, mousse and other food

#		Ø mm
<input checked="" type="checkbox"/> 195010	1/8	79
<input checked="" type="checkbox"/> 195015	1/12	65
<input checked="" type="checkbox"/> 195020	1/16	61
<input checked="" type="checkbox"/> 195025	1/20	56
<input checked="" type="checkbox"/> 195030	1/24	51
<input checked="" type="checkbox"/> 195035	1/30	49
<input checked="" type="checkbox"/> 195040	1/36	46
<input checked="" type="checkbox"/> 195045	1/40	44
<input checked="" type="checkbox"/> 195050	1/50	42
<input checked="" type="checkbox"/> 195055	1/60	39
<input checked="" type="checkbox"/> 195060	1/100	28



**Material: Edelstahl**

- Schwere Profi-Qualität

**Made of stainless steel**

- Heavy quality for professionals

#		Ø mm
195400	1/8	80
195405	1/12	67
195410	1/16	59
195415	1/20	56
195420	1/24	53
195425	1/30	50
195430	1/36	48
195435	1/40	44
195440	1/50	40



**Material: Edelstahl**

- Schwere Profi-Qualität
- „OVAL“

**Made of stainless steel**

- Heavy quality for professionals
- “OVAL”

#		↔ mm
195450	1/30	58 x 46



DE	EISBEHÄLTER		
EN	ICE CREAM CONTAINER	SST	
IT	CONTENITORE PER GELATO		
ES	CONTENEDOR PARA HELADO		



#	↗ mm	→ mm	↑ mm	↓ mm
199613	265	160	170	5,0
199619	330	165	80	3,3
199622	330	165	120	5,0
199623	330	165	150	6,2
199624	330	165	180	7,6
199616	360	165	80	3,3
199610	360	165	120	4,9
199611	360	165	150	6,3
199612	360	165	180	7,3
199615	360	250	80	5,6
199614	360	250	120	8,7
199617	360	250	150	11,2
199618	360	250	180	12,9



DE	EISBEHÄLTER		
EN	ICE CREAM CONTAINER	PC	
IT	CONTENITORE PER GELATO		
ES	CONTENEDOR PARA HELADO		

#	↗ mm	→ mm	↑ mm	↓ mm
199620	360	165	120	4,8
199621	360	250	80	5,3

DE	DECKEL		
EN	LID	PC	
IT	COPERCHIO		
ES	TAPA		

- Passend für Eisbehälter
- Mit Griff
- Suitable for ice cream containers
- With handle



#	↗ mm	→ mm	↑ mm	für/for #
199629	265	160	20	199613
199626	330	165	20	199619, 199622, 199623, 199624
199630	360	165	20	199610, 199611, 199612, 199616, 199620
199625	360	250	82	199614, 199615, 199617, 199618, 199621

DE	SCHABER EDELSTAHL
EN	SCRAPERS STAINLESS STEEL
IT	RASCHIETTI, INOX
ES	RASQUETAS, INOX

Material: Edelstahl

Made of stainless steel

#	↔ mm	
154840	100 x 100	Quadrat / square
154841	110 x 110	Dreieck / triangular
154842	110 x 75	Rechteck / rectangular

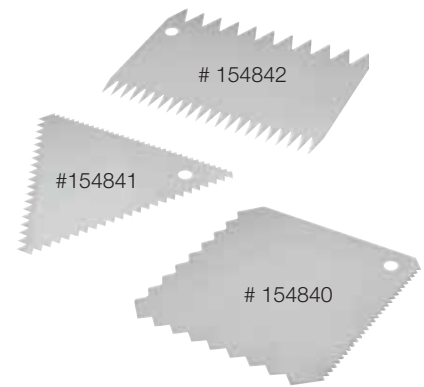

DE	SERVIERTABLETTS OVAL
EN	SERVING TRAYS OVAL
IT	VASSOI DA PORTATA OVALI
ES	BANDEJAS OVALADAS

Material: Edelstahl

Made of stainless steel

- Mit gebördeltem Rand
- **Oberfläche matt**

- With rolled edge
- **Matte finish**

#	↔ mm
155040	145 x 200
155041	180 x 230
155042	195 x 265
155043	220 x 285



DE	SERVIETTENSPENDER / SERVIETTENHALTER
EN	NAPKIN HOLDERS
IT	PORTATOVAGLIOLI
ES	SERVILLETERO

Material: Edelstahl

Made of stainless steel

- Für 100 Servietten:  
– 170 x 170 mm (Maße Serviette entfalten)  
– 85 x 115 mm (Maße Serviette gefalten)
- For 100 napkins:  
– 170 x 170 mm (dimensions napkin unfolded)  
– 85 x 115 mm (dimensions napkin folded)

#	→ mm	↓ mm	↑ mm
195700	95	100	130



DE	LÖFFELFLÖTE / LÖFFELBEHÄLTER
EN	SPOON HOLDER
IT	PORTA CUCCHIAINI
ES	PORTA CUCHARILLA

Material: Acryl

Made of acrylic

- Inklusive Distanzeinlage
- Mit 3 quadratischen Löffelboxen
- Including distance spacer
- With 3 square boxes

#	→ mm	↓ mm	↑ mm
172300	225	150	150





© stockcreations - stock.adobe.com



# 172200    # 172201    # 172202

DE	EISTÜTENHALTER			
EN	ICE CREAM CONE STAND		AC	-40 +50 °C
IT	PORTA CONO GELATO			
ES	SOPORTE DE CONO DE HELADO			

- Mit Schublade
- With drawer

#	○	∅ mm	↗ mm	→ mm	↑ mm	
172200	1	1 x 45	120	110	500	
172201	5	4 x 24 1 x 30	140	140	500	
172202	13	9 x 24 4 x 30	205	205	500	



# 172203    # 172204

DE	EISTÜTENHALTER			
EN	ICE CREAM CONE STAND		AC	-40 +50 °C
IT	PORTA CONO GELATO			
ES	SOPORTE DE CONO DE HELADO			

#	○	∅ mm	↗ mm	→ mm	↑ mm	
172203	18	12 x 24 6 x 30	240	180	590	
172204	18	12 x 24 6 x 30	240	195	615	

DE	EISTÜTENHALTER
EN	ICE CREAM CONE HOLDERS
IT	PORTA CONI
ES	PORTA CONOS DE HELADO

Material: Edelstahl  
 • Mit Antirutsch-Füßchen

Made of stainless steel  
 • With non-slip feet

**Für 3 Eistüten**

**For 3 cones**

#	Ø mm	→ mm	↓ mm	↑ mm
190300	26	200	95	85

**Für 4 Eistüten**

**For 4 cones**

#	Ø mm	→ mm	↓ mm	↑ mm
190305	26	270	95	85

**Für 4 Eistüten, "MAXI"**

**For 4 cones, "MAXI"**

#	Ø mm	→ mm	↓ mm	↑ mm
190308	2 x 26/2 x 31	270	95	85

Material: Acryl  
**Für 3 Eistüten**

Made of acrylic  
**For 3 cones**

#	Ø mm	→ mm	↓ mm	↑ mm
172100	34	185	90	95

**Für 4 Eistüten**

**For 4 cones**

#	Ø mm	→ mm	↓ mm	↑ mm
172101	34	250	90	95

Material: Edelstahl  
**Für 4 Eistüten**

Made of stainless steel  
**For 4 cones**

#	Ø mm	↑ mm
190310	165	140





© Igor Normann - stock.adobe.com



DE	SCHOKOLADEN-FONTÄNE
EN	CHOCOLATE FOUNTAIN
IT	FONTANA DI CIOCCOLATO
ES	FUENTE DE CHOCOLATE

- Material: Edelstahl
- Temperatur einstellbar: 0 – 80 °C
  - Bodendurchmesser: 33 cm
  - Spannung: 240 V, 50/60 HZ

- Made of stainless steel
- Temperature adjustable: 0 – 80 °C
  - Bottom diameter: 33 cm
  - Voltage: 240 V, 50/60 HZ

#	↑ mm	⚖ kg	🔌	
255320	600	5 kg	150 W	



- Material: Edelstahl
- Temperatur einstellbar: 0 – 80 °C
  - Spannung: 240 V, 50/60 HZ

- Made of stainless steel
- Temperature adjustable: 0 – 80 °C
  - Voltage: 240 V, 50/60 HZ

#	↑ mm	⚖ kg	🔌	
255350	800	8	215 W	

DE	REINIGUNGSBÜRSTE
EN	CLEANING BRUSH
IT	SPAZZOLA PER PULIZIA
ES	CEPILLO LIMPIADOR

- Material: Verzinkter Draht, Borsten Nylon

- Made of galvanised wire, bristles nylon

#	↔ mm	
120655	700 x 120 x 55	



DE	DOSIERGERÄT "PRALINENFIX D"	
EN	DOSING METER "PRALINENFIX D"	
IT	DOSATRICE PER CIOCCOLATINI "PRALINENFIX D"	
ES	DOSIFICADOR PARA RELLENAR BOMBONES "PRALINENFIX D"	

Material: Edelstahl

- Speziell für flüssige Massen wie Schokolade, Kuvertüre, Ganache, Nougat etc.
- Zum schnellen, exakten und gleichmäßigen Füllen von Hohlkugeln
- Dosierung erfolgt stufenlos Reihe für Reihe mit Hilfe von 7 verstellbaren Tüllen
- Über 100 Füllungen pro Minute
- Beheizte Kolbeneinheiten
- Einfache Reinigung und Handhabung

Made of stainless steel

- Especially for liquid masses like chocolate, couverture, ganache, nougat etc.
- For fast, precise and equal filling of hollow shells
- Dosing is done steplessly row by row with the help of 7 adjustable nozzles
- More than 100 fillings per minute
- Heated piston units
- Easy cleaning and handling



#	↔ mm	⚖ kg	⚡	🔌
450500	510 x 400 x 570	17	10 W	230 V / 50 Hz

DE	DOSIERGERÄT "PRALINENFIX B"	
EN	DOSING METER "PRALINENFIX B"	
IT	DOSATRICE PER CIOCCOLATINI "PRALINENFIX B"	
ES	DOSIFICADOR PARA RELLENAR BOMBONES "PRALINENFIX B"	

Material: Edelstahl

- Speziell für Formen von **Chocolate World**
- Speziell für flüssige Massen wie Schokolade, Kuvertüre, Ganache, Nougat etc.
- Zum schnellen, exakten und gleichmäßigen Füllen von Pralinenformen
- Dosierung erfolgt stufenlos Reihe für Reihe mit Hilfe von 8 verstellbaren Tüllen
- Über 100 Füllungen pro Minute
- Beheizte Kolbeneinheiten
- Einfache Reinigung und Handhabung

Made of stainless steel

- Especially for moulds from **Chocolate World**
- Especially for liquid masses like chocolate, couverture, ganache, nougat etc.
- For fast, precise and equal filling of chocolate moulds
- Dosing is done steplessly row by row with the help of 8 adjustable nozzles
- More than 100 fillings per minute
- Heated piston units
- Easy cleaning and handling

#	↔ mm	⚖ kg	⚡	🔌
450510	510 x 400 x 570	17	10 W	230 V / 50 Hz



12

DE	ZUBEHÖR: LIKÖRTÜLLE	
EN	EQUIPMENT: LIQUEUR TUBE	
IT	ACCESSORIO PER FARCIRE PRALINE AL LIQUORE	
ES	ACCESORIO PARA RELLENAR BOMBONES DE LICOR	

#		
450520		



Geeignet zum Schneiden und Einteilen von Schokolade, Pralinen, Marzipan, Fruchtgelee, Gebäck, etc.  
 Suitable for cutting and dividing chocolate, pralines, marzipan, fruit jelly, pastries, etc.



DE	PRALINENSCHNEIDER GITARRE	<b>SST</b>
EN	PRALINE CUTTER GUITAR	
IT	CHITARRA TAGLIERINA PER CIOCCOLATO	
ES	GUITARRA CORTADOR DE CHOCOLATE	

- Inklusive 3 Rahmen
  - Schnittgrößen: 15, 22,5, 30 mm
  - Schneidetisch: 410 x 380 mm
  - Inklusive Wendepatte: 370 x 400 mm
  - Inklusive 10 Ersatzdrähten
  - Inklusive Werkzeug
- Including 3 frames
  - Cutting sizes: 15, 22,5, 30 mm
  - Cutting table: 410 x 380 mm
  - Including turning plate: 370 x 400 mm
  - Including 10 spare wires
  - Including tool

#	↗ mm	→ mm	↑ mm	⚖ kg
255010	700	480	110	20,5

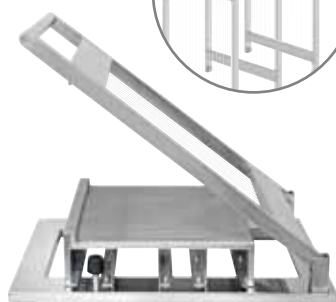
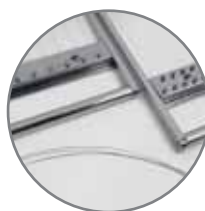



DE	PRALINENSCHNEIDER GITARRE	<b>SST</b>
EN	PRALINE CUTTER GUITAR	
IT	CHITARRA TAGLIERINA PER CIOCCOLATO	
ES	GUITARRA CORTADOR DE CHOCOLATE	

- Inklusive 3 Rahmen
  - Schnittgrößen: 10, 20, 30 mm
  - Schneidetisch: 310 x 310 mm
- Including 3 frames
  - Cutting sizes: 10, 20, 30 mm
  - Cutting table: 310 x 310 mm

#	↗ mm	→ mm	↑ mm	⚖ kg
255000	600	340	128	23,0

DE	SCHOKOLADEN TEMPERIERGERÄT	
EN	CHOCOLATE MELTER	SST
IT	TEMPERATRICE DI CIOCCOLATO	
ES	TEMPERADOR DE CHOCOLATE	

- |  |  |
|--|--|
| <ul style="list-style-type: none"> <li>• Speziell für Schokolade</li> <li>• Gehäuse, Behälter und Deckel aus Edelstahl</li> <li>• Digitales Touchbedienfeld</li> <li>• Inklusive Temperaturfühler</li> <li>• <b>Achtung: Wasserbad-Funktion</b></li> </ul> | <ul style="list-style-type: none"> <li>• Especially for chocolate</li> <li>• Housing, container and lid made of stainless steel</li> <li>• Digital touch control panel</li> <li>• Temperature probe included</li> <li>• <b>Attention: Bain-Marie Function</b></li> </ul> |
|--|--|

#	255800	255850	255860
Behälter (Tiefe) / Container (Depth)	<b>GN 1/2</b> – 100 mm	<b>GN 1/1</b> – 100 mm	<b>GN 1/1</b> – 150 mm
Volumen / Volume (l.)	6,0	13,0	17,0
für Schokolade / for chocolate (kg)	5,0	12,0	15,0
↔ mm	440 x 340 x 200	700 x 390 x 200	700 x 390 x 250
	800 W / 50 – 60 Hz 220 – 240 V	1200 W / 50 – 60 Hz 220 – 240 V	1200 W / 50 – 60 Hz 220 – 240 V
 kg	8,0	12,0	13,8
°C	0° – 50°C	0° – 50°C	0° – 50°C



DE	SCHOKOLADENSPENDER	
EN	CHOCOLATE DISPENSER	SST PP  
IT	DISPENSER DI CIOCCOLATO	
ES	DISPENSADOR DE CHOCOLATE	

- |  |  |
|--|--|
| <ul style="list-style-type: none"> <li>• Garantiert ein kontinuierliches Rühren und Verteilen der Schokolade</li> <li>• Passend für # 255860 (GN 1/1, 150 mm)</li> </ul> | <ul style="list-style-type: none"> <li>• Guarantees continuous stirring and distribution of the chocolate</li> <li>• Suitable for # 255860 (GN 1/1, 150 mm)</li> </ul> |
|--|--|

#	255880
↔ mm	490 x 410 x 340
	120 W
	230 V 50 – 60 HZ
	42 U / min 42 rpm
 kg	7,65

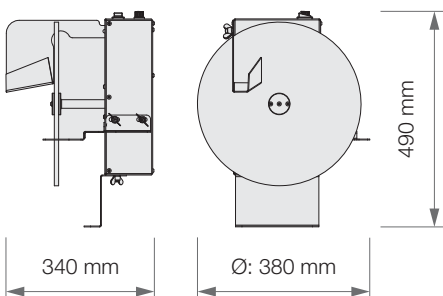



DE	PRALINENTUNKGABEL-SET
EN	DIPPING FORK SET
IT	SET FORCHETTINE PRALINERIA, INOX
ES	JUEGO DE PARA BOMBONES DE CHOCOLATE

- |   |  |
|---|--|
| Material: Edelstahl<br>• Griff: Kunststoff (ABS), schwarz<br>• Inklusive Kunststoffkoffer<br>(L x B x H: 240 x 195 x 45 mm) | Made of stainless steel<br>• Handle: plastic, black (ABS)<br>• With plastic storage case<br>(L x W x H: 240 x 195 x 45 mm) |
|---|--|

Set bestehend aus:  
 je 1 Stück rund (14, 16, 18, 20 mm),  
 Dreieck, Spirale, Tropfen, 2-, 3-, 4-zinkig

Set consisting of 1 fork each:  
 round (dia. 14, 16, 18, 20 mm) triangle,  
 spiral and drop, 2, 3 and 4 points

#		
199033	10-teilig / 10 pieces	



DE	PRALINENTUNKGABEL-SET GROSS
EN	DIPPING FORK SET LARGE
IT	SET FORCHETTINE PRALINERIA GRANDE
ES	JUEGO DE TENEDORES PARA BOMBONES DE CHOCOLATE GRANDE

- |  |  |
|--|--|
| Material: Edelstahl<br>• Griff: Kunststoff (ABS), schwarz<br>• Aufbewahrungs-Ständer aus Edelstahl,<br>aufklappbar, mit Anti-Rutsch-Füßen<br>(L x B x H: 275 x 200 x 225 mm)<br>• Inklusive Kunststoffkoffer<br>(L x B x H: 305 x 260 x 50 mm) | Made of stainless steel<br>• Handle: plastic, black (ABS)<br>• Including rack made of stainless steel,<br>foldable with non-slip feet<br>(L x W x H: 275 x 200 x 225 mm)<br>• Including plastic storage case<br>(L x W x H: 305 x 260 x 50 mm) |
|--|--|

Set bestehend aus:  
 je 1 Stück rund (14, 16, 18, 20 mm),  
 Dreieck, Spirale, Tropfen, 2-, 3-, 4-zinkig

Set consisting of 1 fork each:  
 round (dia. 14, 16, 18, 20 mm) triangle,  
 spiral and drop, 2, 3 and 4 points

#		
199034	10-teilig + Ständer / 10 pieces + rack	

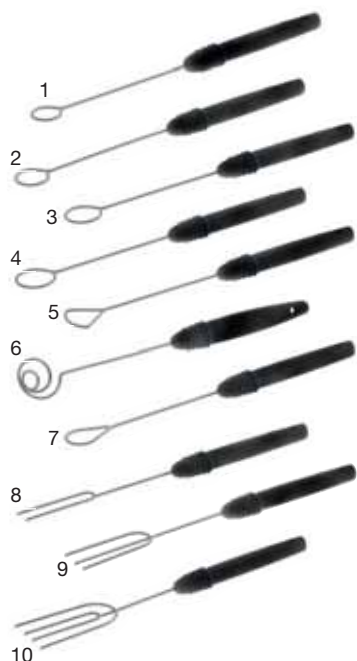

DE	PRALINENTUNKGABELN
EN	DIPPING FORKS
IT	FORCHETTINE PRALINERIA
ES	TENEDORES PARA BOMBONES DE CHOCOLATE

- |   |   |
|---|---|
| Material: Edelstahl<br>• Griff: Kunststoff (ABS), schwarz | Made of stainless steel<br>• Handle: plastic, black (ABS) |
|---|---|

#			↗ mm
199120	rund / round	1	14
199121	rund / round	2	16
199122	rund / round	3	18
199123	rund / round	4	20
199124	Dreieck / triangle	5	
199125	Spirale / spiral	6	
199126	Tropfen / drop	7	
199130	2-zinkig / 2 points	8	
199128	3-zinkig / 3 points	9	
199129	4-zinkig / 4 points	10	



DE	PRALINEN-VORRATSDOSE
EN	STORAGE BOX FOR CHOCOLATES
IT	CONTENITORE PER CIOCCOLATINI
ES	CONTENEDOR PARA BOMBONES

Material: PS, glasklar und stapelbar      Made of PS, crystal clear undstackable

#	↗ mm	→ mm	↑ mm
230030	335	225	73

DE	SPRÜHPISTOLE "ALEXO 500+"
EN	SPRAY GUN "ALEXO 500+"
IT	PISTOLA POLVERIZZATRICE ELETTRICA DA CIOCCOLATO "ALEXO 500+"
ES	PISTOLA PULVERIZADORA ELÉCTRICA PARA CHOCOLATE "ALEXO 500+"

- |  |  |
|--|--|
| <ul style="list-style-type: none"> <li>• Speziell für flüssige Schokolade (50 % Schokolade / 50 % Kakaobutter)</li> <li>• <b>100 % lebensmittelecht</b>, 29 – 40 °C</li> <li>• Fördermenge: 140 – 220 ml/min</li> <li>• Viskosität: max. 80 DIN/Sek.</li> <li>• Inhalt: 700 ml; Gewicht: 2,0 kg</li> <li>• Leistung: 60 W</li> </ul> | <ul style="list-style-type: none"> <li>• Especially for liquid chocolate (50 % chocolate / 50 % cocoa butter)</li> <li>• <b>100% food safe</b>, useable from 29° to 40° C</li> <li>• Output: 140 – 220 ml/min</li> <li>• Viscosity: max. 80 DIN/sec.</li> <li>• Volume: 700 ml; weight: 2.0 kg</li> <li>• Power: 60 W</li> </ul> |
|--|--|

Wird mit Rundstrahldüse R6 geliefert

Delivery includes circular jet nozzle R6



**TIPP!**  
50% Schokolade / 50% Kakaobutter  
Temperatur: +29 / +40 °C

#		
153971	Sprühpistole "ALEXO 500+" / Spray gun "ALEXO 500+"	
153975	Ersatzbehälter mit Deckel / with lid	
153989	Wärmeschutz / insulation sleeve	

DE	KUVERTÜRE- / SCHOKOLADE-ABSTECHER
EN	CHOCOLATE GRATERS
IT	RASCHIA TAGLIA CIOCCOLATA
ES	CORTADORES PARA CHOCOLATE

- |                          |                         |
|--------------------------|-------------------------|
| Material: Edelstahl      | Made of stainless steel |
| • Materialstärke: 0,8 mm | • Thickness: 0.8 mm     |

#	↔ mm	
200610	120 x 115	flach / flat
200611	120 x 110	abgerundet / oblique



DE	SPACHTEL – EXTRA STABIL
EN	SPATULA – EXTRA STRONG
IT	RASCHIA – EXTRA RESISTENTE
ES	ESPATULA PAR CHOCOLATE – MUY FUERTE

- |                                       |   |
|---------------------------------------|---|
| Material: Edelstahl, Griff Kunststoff | Made of stainless steel, plastic handle |
| • Speziell für Schokolade             | • Especially for chocolate              |

#	→ mm
<input checked="" type="checkbox"/> 200700	170
<input checked="" type="checkbox"/> 200701	270
<input checked="" type="checkbox"/> 200710	180



12

DE	KASSEROLLE
EN	SAUCEPAN
IT	CARAFFA GRADUATA PER MICROONDE
ES	CAZO DE POLIPROPILENO PARA FUNDIR CHOCOLATE EN MICROONDAS

- |  |   |
|--|---|
| Material: PP, weiß   | Made of PP, white   |
| • Mit geprägter Skala in Innenseite und zusätzl. blauem Skalendruck auf der Außenseite | • With inside scale and blue printed litre and ml scale outside |
| • Bruchsicher und hygienisch   | • Break resistant   |
| • Auch für Mikrowellengeräte geeignet  | • Suitable for microwave  |
| • Volumen: 2,0 Liter   | • Volume: 2.0 liters  |

#	↗ mm	Ø mm	↑ mm
290200	335	190	120



DE	SCHOKOLADENFORMEN	
EN	CHOCOLATE MOULDS	
IT	STAMPI PER CIOCCOLATO	
ES	MOLDES PARA CHOCOLATE	



Das Gewicht wurde auf der Grundlage von Vollmilch-Schokolade bestimmt und kann je nach Schokoladensorte, der Füllung sowie der Gießtechnik, Abweichungen verzeichnen.  
 Material: Polycarbonat (Kunststoff), sehr robust und stoßfest.

Il peso è determinato in base al cioccolato a latte e può subire variazioni secondo il tipo di cioccolato, il ripieno e la tecnica di fusione.  
 Materiale: policarbonato (plastica), extra robusta e resistente agli urti.

The weight is based on a moulding with solid milk chocolate and may depend on your chocolate, filling and way of moulding.  
 Material: polycarbonate (plastic), very robust and shockproof.

El peso queda determinado a base de chocolate con leche entera y puede ser distinto según el tipo de chocolate, relleno y técnica de moldeo.  
 Material: policarbonato (plástico), muy robusto y resistente a los choques.

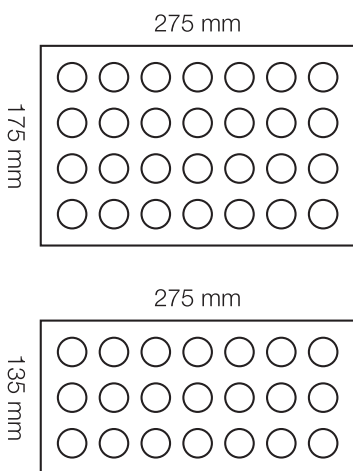

Artikelnummer mit der Bezeichnung „**DF**“ = **Doppelform**. Es wird empfohlen, 2 Formen für die Pralinenherstellung zu verwenden. Jede **DF** hat Zentrierlöcher, damit die Formen zusammen passen. Es müssen pro **DF** mindestens 2 Verbindungsstifte benutzt werden. Von dem Verbindungsstift gibt es nur eine Größe (# 429999). Für jede DF können individuell zwischen 2-4 Klammern verwendet werden, damit die Formen geschlossen zusammenhalten. Bei den Klammern hängt die Größe von der Rahmenhöhe der Schokoladenform ab.

Article number with the description „**DM**“ = **Double mould**. It is recommended, to use 2 moulds for praline making. Each **DM** has centering holes, so that the moulds fit together. At least 2 connecting pins must be used per **DM**. There is only one size of the connecting pin (# 429999). Between 2-4 clamps can be used individually for each DM, to keep the moulds closed together. For the clamps, the size depends on the frame height of the chocolate mould.

DE	ZUBEHÖR FÜR DOPPELFORMEN
EN	ACCESSORIES FOR DOUBLE MOULDS
IT	ACCESSORI PER STAMPI DOPPI
ES	ACCESORIOS PARA MOLDES DOBLES



**KLAMMER, Kunststoff**  
**CLAMP, made of plastic**

#	↑ mm
429998	24

**VERBINDUNGSSTIFT, Edelstahl**  
**CONNECTING PIN, stainless steel**

#	↑ mm
429999	



**KLAMMER, Edelstahl**  
**CLAMP, stainless steel**

#	↑ mm
429990	22
429991	23
429992	26
429993	28

#	↑ mm
429994	30
429995	32
429996	35
429997	40



Anwendungsbeispiele / Application examples

DE	VALENTIN
EN	VALENTINE
IT	SAN VALENTINO
ES	SAN VALENTÍN



#	421012
↙↑ mm	275 x 135 x 24
Stückzahl / pcs.	3 x 8
↔ mm	31 x 29 x 19
Stk./g	13



#	421023
↙↑ mm	275 x 135 x 24
Stückzahl / pcs.	3 x 8
↔ mm	30 x 22 x 20
Stk./g	11



#	421214
↙↑ mm	275 x 135 x 24
Stückzahl / pcs.	3 x 8
↔ mm	31 x 35 x 18
Stk./g	15



# - DF / DM	421280
↙↑ mm	275 x 135 x 24
Stückzahl / pcs.	3 x 8
↔ mm	30 x 26 x 9
Stk./g	2 x 5



#	421296
↙↑ mm	275 x 135 x 24
Stückzahl / pcs.	3 x 7
↔ mm	49 x 26 x 17
Stk./g	15



#	421417
↙↑ mm	275 x 135 x 24
Stückzahl / pcs.	3 x 8
↔ mm	33 x 31 x 15
Stk./g	11



# - DF / DM	421513
↙↑ mm	275 x 135 x 24
Stückzahl / pcs.	3 x 7
↔ mm	35 x 33 x 11
Stk./g	2 x 8,6



#	421526
↙↑ mm	275 x 135 x 24
Stückzahl / pcs.	4 x 7
↔ mm	31 x 27 x 17
Stk./g	9



#	421726
↙↑ mm	275 x 135 x 24
Stückzahl / pcs.	3 x 12
↔ mm	32 x 15,5 x 8
Stk./g	2,5



#	421937
↙↑ mm	275 x 135 x 24
Stückzahl / pcs.	3 x 7
↔ mm	42 x 21,5 x 15
Stk./g	8,5



# - DF / DM	421145
↙↑ mm	275 x 135 x 24
Stückzahl / pcs.	2 x 4
↔ mm	65 x 57 x 14
Stk./g	2 x 35



# - DF / DM	421146
↙↑ mm	275 x 135 x 24
Stückzahl / pcs.	1 x 5
↔ mm	80 x 69 x 16
Stk./g	2 x 68

DE	VALENTIN
EN	VALENTINE
IT	SAN VALENTINO
ES	SAN VALENTÍN



#	421147
↔ ↑ mm	275 x 135 x 24
Stückzahl / pcs.	1 x 3
↔ mm	95 x 83 x 19
Stk./g	118



#	421148
↔ ↑ mm	275 x 135 x 26
Stückzahl / pcs.	1 x 2
↔ mm	119 x 104 x 23
Stk./g	2 x 205



#	421218
↔ ↑ mm	275 x 135 x 24
Stückzahl / pcs.	3 x 7
↔ mm	30 x 36 x 19
Stk./g	14



#	421576
↔ ↑ mm	275 x 135 x 24
Stückzahl / pcs.	3 x 7 / 3 Fig.
↔ mm	29 x 34,5 x 17
Stk./g	12



#	421744
↔ ↑ mm	275 x 135 x 24
Stückzahl / pcs.	3 x 8
↔ mm	33 x 22,5 x 16
Stk./g	10,5



#	422121
↔ ↑ mm	275 x 175 x 24
Stückzahl / pcs.	1 x 2
↔ mm	145 x 126 x 20
Stk./g	305



#	422122
↔ ↑ mm	275 x 175 x 24
Stückzahl / pcs.	1 x 2
↔ mm	145 x 126 x 20
Stk./g	300



#	421892
↔ ↑ mm	275 x 135 x 24
Stückzahl / pcs.	3 x 6
↔ mm	33 x 33 x 10
Stk./g	5



#	421893
↔ ↑ mm	275 x 135 x 24
Stückzahl / pcs.	3 x 7
↔ mm	43 x 23,5 x 13,5
Stk./g	8,5

DE	OSTERN
EN	EASTER
IT	PASQUA
ES	PASCUA



# - DF / DM	421053
↔ ↑ mm	275 x 135 x 24
Stückzahl / pcs.	4 x 8
↔ mm	32 x 22 x 11
Stk./g	2 x 5



# - DF / DM	421266
↔ ↑ mm	275 x 135 x 24
Stückzahl / pcs.	3 x 8
↔ mm	35 x 23 x 12
Stk./g	2 x 6



# - DF / DM	421317
↔ ↑ mm	275 x 135 x 24
Stückzahl / pcs.	3 x 8
↔ mm	43 x 30 x 14
Stk./g	2 x 12



#	421362
↔ ↑ mm	275 x 135 x 24
Stückzahl / pcs.	3 x 8
↔ mm	38 x 25 x 14
Stk./g	12



# - DF / DM	421383
↔ ↑ mm	275 x 135 x 24
Stückzahl / pcs.	3 x 8
↔ mm	42 x 27 x 14
Stk./g	2 x 11



# - DF / DM	421516
↔ ↑ mm	275 x 135 x 24
Stückzahl / pcs.	5 x 7
↔ mm	29 x 21 x 10
Stk./g	2 x 4



# - DF / DM	421537
↔ ↑ mm	275 x 135 x 24
Stückzahl / pcs.	3 x 9
↔ mm	35 x 23 x 12
Stk./g	2 x 6



# - DF / DM	421050
↔ ↑ mm	275 x 135 x 24
Stückzahl / pcs.	5 x 7
↔ mm	29 x 21 x 10
Stk./g	2 x 4



# - DF / DM	421251
↔ ↑ mm	275 x 135 x 28
Stückzahl / pcs.	2 x 4
↔ mm	70 x 47 x 25
Stk./g	2 x 54



# - DF / DM	421252
↔ ↑ mm	275 x 135 x 32
Stückzahl / pcs.	2 x 3
↔ mm	81 x 54 x 30
Stk./g	2 x 83



# - DF / DM	421253
↔ ↑ mm	275 x 135 x 32
Stückzahl / pcs.	2 x 3
↔ mm	86 x 58 x 30
Stk./g	2 x 97



# - DF / DM	421254
↔ ↑ mm	275 x 135 x 35
Stückzahl / pcs.	2 x 2
↔ mm	100 x 65 x 35
Stk./g	2 x 135

DE	OSTERN
EN	EASTER
IT	PASQUA
ES	PASCUA



# - DF / DM	421255
↔ ↑ mm	275 x 135 x 40
Stückzahl / pcs.	1 x 3
↔ mm	118 x 77 x 40
Stk./g	2 x 227



# - DF / DM	421582
↔ ↑ mm	275 x 135 x 24
Stückzahl / pcs.	3 x 8
↔ mm	33 x 23 x 12
Stk./g	2 x 5



# - DF / DM	421640
↔ ↑ mm	275 x 135 x 24
Stückzahl / pcs.	3 x 6
↔ mm	34 x 35 x 14
Stk./g	2 x 12



#	421641
↔ ↑ mm	275 x 135 x 24
Stückzahl / pcs.	3 x 7 / 7 Fig.
↔ mm	31 x 31 x 9
Stk./g	9



# - DF / DM	421656
↔ ↑ mm	275 x 135 x 24
Stückzahl / pcs.	3 x 6
↔ mm	38 x 27,5 x 15
Stk./g	2 x 7



# - DF / DM	421664
↔ ↑ mm	275 x 135 x 30
Stückzahl / pcs.	3 x 4 / 3 Fig.
↔ mm	62 x 41,5 x 23
Stk./g	2 x 35



# - DF / DM	421739
↔ ↑ mm	275 x 135 x 24
Stückzahl / pcs.	1 x 4
↔ mm	99,5 x 45,5 x 19
Stk./g	2 x 49



# - DF / DM	421786
↔ ↑ mm	275 x 135 x 24
Stückzahl / pcs.	3 x 8
↔ mm	33 x 26,5 x 13
Stk./g	2 x 13



# - DF / DM	421873
↔ ↑ mm	275 x 135 x 40
Stückzahl / pcs.	2 x 3
↔ mm	72 x 55 x 35
Stk./g	2 x 46,6



# - DF / DM	421888
↔ ↑ mm	275 x 135 x 35
Stückzahl / pcs.	2 x 3
↔ mm	86,5 x 56,5 x 25,5
Stk./g	2 x 69,7



# - DF / DM	421889
↔ ↑ mm	275 x 135 x 40
Stückzahl / pcs.	2 x 3
↔ mm	86,5 x 56,5 x 33,5
Stk./g	2 x 89,5

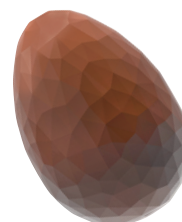

# - DF / DM	421891
↔ ↑ mm	275 x 135 x 24
Stückzahl / pcs.	3 x 8
↔ mm	33 x 23 x 11
Stk./g	2 x 5,5

DE	OSTERN
EN	EASTER
IT	PASQUA
ES	PASCUA



# - DF / DM	421907
←↑ mm	275 x 135 x 24
Stückzahl / pcs.	5 x 7
↔ mm	29 x 21 x 10
Stk./g	2 x 4



# - DF / DM	421910
←↑ mm	275 x 135 x 35
Stückzahl / pcs.	2 x 3
↔ mm	86,5 x 56 x 30
Stk./g	2 x 94,5



# - DF / DM	422395
←↑ mm	275 x 175 x 24
Stückzahl / pcs.	4 x 8 / 3 Fig.
↔ mm	33 x 23 x 12
Stk./g	2 x 5



DE	WEIHNACHTEN UND NEUJAHR
EN	CHRISTMAS AND NEW YEAR
IT	NATALE E CAPODANNO
ES	NAVIDAD Y AÑO NUEVO



#	421209
←↑ mm	275 x 135 x 24
Stückzahl / pcs.	2 x 7
↔ mm	57 x 32 x 7
Stk./g	5



# - DF / DM	421635
←↑ mm	275 x 135 x 24
Stückzahl / pcs.	2 x 4
↔ mm	48 x 40 x 18
Stk./g	2 x 16



# - DF / DM	422037
←↑ mm	275 x 175 x 24
Stückzahl / pcs.	2 x 9
↔ mm	66 x 23 x 12
Stk./g	2 x 11

DE	WEIHNACHTEN UND NEUJAHR
EN	CHRISTMAS AND NEW YEAR
IT	NATALE E CAPODANNO
ES	NAVIDAD Y AÑO NUEVO



# - DF / DM	422038
↔ ↑ mm	275 x 175 x 24
Stückzahl / pcs.	6 x 2
↔ mm	90 x 24 x 12
Stk./g	2 x 15



#	421078
↔ ↑ mm	275 x 135 x 24
Stückzahl / pcs.	4 x 3 / 2 Fig.
↔ mm	67 x 29 x 8
Stk./g	9,5



#	421079
↔ ↑ mm	275 x 135 x 24
Stückzahl / pcs.	1 x 6
↔ mm	110 x 36 x 10
Stk./g	34



#	421302
↔ ↑ mm	275 x 135 x 24
Stückzahl / pcs.	3 x 7
↔ mm	40 x 30 x 15
Stk./g	12



#	421333
↔ ↑ mm	275 x 135 x 24
Stückzahl / pcs.	3 x 7
↔ mm	38 x 30 x 20
Stk./g	15



#	421406
↔ ↑ mm	275 x 135 x 24
Stückzahl / pcs.	3 x 6 / 6 Fig.
↔ mm	43 x 32 x 7
Stk./g	6



#	421439
↔ ↑ mm	275 x 135 x 24
Stückzahl / pcs.	3 x 4
↔ mm	57 x 32 x 10
Stk./g	7



#	421655
↔ ↑ mm	275 x 135 x 24
Stückzahl / pcs.	1 x 6
↔ mm	100 x 35 x 13
Stk./g	30



# - DF / DM	421868
↔ ↑ mm	275 x 135 x 30
Stückzahl / pcs.	1 x 4
↔ mm	100 x 59 x 21
Stk./g	55,5 + 49



#	421869
↔ ↑ mm	275 x 135 x 24
Stückzahl / pcs.	3 x 8
↔ mm	34,5 x 25 x 18
Stk./g	10,5



#	421870
↔ ↑ mm	275 x 135 x 24
Stückzahl / pcs.	3 x 7
↔ mm	40 x 25 x 18
Stk./g	10,5



# - DF / DM	421878
↔ ↑ mm	275 x 135 x 30
Stückzahl / pcs.	1 x 4
↔ mm	80 x 59
Stk./g	57 + 50,5

DE	NATUR
EN	NATURE
IT	NATURA
ES	NATURALEZA



#	421033
↙↑ mm	275 x 135 x 24
Stückzahl / pcs.	3 x 7
↔ mm	34 x 34 x 20
Stk./g	18



#	421048
↙↑ mm	275 x 135 x 24
Stückzahl / pcs.	2 x 5 / 5 Fig.
↔ mm	43 x 43 x 5
Stk./g	6



#	421058
↙↑ mm	275 x 135 x 24
Stückzahl / pcs.	3 x 7
↔ mm	28 x 28 x 20
Stk./g	12



#	421134
↙↑ mm	275 x 135 x 24
Stückzahl / pcs.	3 x 8
↔ mm	33 x 24 x 20
Stk./g	13



#	421519
↙↑ mm	275 x 135 x 24
Stückzahl / pcs.	3 x 7
↔ mm	33 x 27 x 17
Stk./g	11,5



#	421637
↙↑ mm	275 x 135 x 24
Stückzahl / pcs.	3 x 8
↔ mm	26 x 26 x 16
Stk./g	10



# - DF / DM	421826
↙↑ mm	275 x 135 x 24
Stückzahl / pcs.	3 x 6
↔ mm	37,5 x 34,5 x 6
Stk./g	2 x 5



#	421830
↙↑ mm	275 x 135 x 24
Stückzahl / pcs.	3 x 7
↔ mm	44,5 x 26 x 13,5
Stk./g	10



# - DF / DM	421197
↙↑ mm	275 x 135 x 24
Stückzahl / pcs.	3 x 7
↔ mm	30 x 30 x 15
Stk./g	2 x 8



#	421568
↙↑ mm	275 x 135 x 24
Stückzahl / pcs.	4 x 8
↔ mm	25 x 24,5 x 18
Stk./g	8



#	421669
↙↑ mm	275 x 135 x 24
Stückzahl / pcs.	2 x 5
↔ mm	41 x 41 x 7
Stk./g	13



# - DF / DM	421917
↙↑ mm	275 x 135 x 24
Stückzahl / pcs.	3 x 7
↔ mm	30 x 30 x 10
Stk./g	2 x 5

DE	ÜBERZIEHPRALINEN
EN	ENROBED CHOCOLATES
IT	CIOCCOLATINI RICOPERTI
ES	BOMBONES BAÑADOS



#	421037
↔ ↑ mm	275 x 135 x 24
Stückzahl / pcs.	3 x 7
↔ mm	35 x 35 x 21
Stk./g	16



#	421219
↔ ↑ mm	275 x 135 x 24
Stückzahl / pcs.	3 x 8
↔ mm	27 x 22 x 15
Stk./g	11



#	421290
↔ ↑ mm	275 x 135 x 24
Stückzahl / pcs.	3 x 8
↔ mm	29 x 29 x 17
Stk./g	11



#	421300
↔ ↑ mm	275 x 135 x 24
Stückzahl / pcs.	3 x 8
↔ mm	33 x 22 x 18
Stk./g	11



#	421384
↔ ↑ mm	275 x 135 x 24
Stückzahl / pcs.	3 x 8
↔ mm	36 x 25 x 19
Stk./g	16



#	421393
↔ ↑ mm	275 x 135 x 24
Stückzahl / pcs.	3 x 8
↔ mm	36 x 26 x 18
Stk./g	18



#	421561
↔ ↑ mm	275 x 135 x 24
Stückzahl / pcs.	3 x 7
↔ mm	27,5 x 27,5 x 14,9
Stk./g	7,15



#	422432
↔ ↑ mm	275 x 175 x 24
Stückzahl / pcs.	4 x 8
↔ mm	34,5 x 25,7 x 17
Stk./g	14

© stock.adobe.com

DE	HERBST UND NÜSSE
EN	AUTUMN AND NUTS
IT	AUTUNNO E NOCI
ES	OTOÑO Y NUECES



#	421015
↔ ↑ mm	275 x 135 x 24
Stückzahl / pcs.	3 x 8
↔ mm	38 x 29 x 18
Stk./g	13



#	421027
↔ ↑ mm	275 x 135 x 24
Stückzahl / pcs.	3 x 8
↔ mm	37 x 27 x 18
Stk./g	12



#	421046
↔ ↑ mm	275 x 135 x 24
Stückzahl / pcs.	3 x 7
↔ mm	37 x 31 x 16
Stk./g	14



#	421089
↔ ↑ mm	275 x 135 x 24
Stückzahl / pcs.	3 x 8
↔ mm	37 x 31 x 20
Stk./g	16



# - DF / DM	421093
↔ ↑ mm	275 x 135 x 24
Stückzahl / pcs.	3 x 8
↔ mm	37 x 29 x 14
Stk./g	2 x 7,5



#	421095
↔ ↑ mm	275 x 135 x 24
Stückzahl / pcs.	3 x 5
↔ mm	49 x 36 x 13
Stk./g	17



#	421104
↔ ↑ mm	275 x 135 x 24
Stückzahl / pcs.	3 x 7
↔ mm	40 x 35 x 10
Stk./g	10



#	421191
↔ ↑ mm	275 x 135 x 24
Stückzahl / pcs.	2 x 11
↔ mm	47 x 19 x 17
Stk./g	13



#	421226
↔ ↑ mm	275 x 135 x 24
Stückzahl / pcs.	3 x 8
↔ mm	29 x 28 x 17
Stk./g	12



#	421483
↔ ↑ mm	275 x 135 x 24
Stückzahl / pcs.	4 x 5
↔ mm	49 x 28 x 15
Stk./g	21



#	422343
↔ ↑ mm	275 x 175 x 24
Stückzahl / pcs.	6 x 3
↔ mm	77 x 18 x 19
Stk./g	27

DE	KAFFEEBOHNEN
EN	COFFEE BEANS
IT	CHICCHI DI CAFFÈ
ES	GRANOS DE CAFÉ



#	421019
↙↑ mm	275 x 135 x 28
Stückzahl / pcs.	4 x 9
↔ mm	25 x 25 x 25
Stk./g	14



#	421327
↙↑ mm	275 x 135 x 24
Stückzahl / pcs.	3 x 8
↔ mm	36 x 24 x 16
Stk./g	11



#	421529
↙↑ mm	275 x 135 x 24
Stückzahl / pcs.	4 x 7
↔ mm	33 x 22 x 14,5
Stk./g	8,6



# - DF / DM	422370
↙↑ mm	275 x 175 x 26
Stückzahl / pcs.	3 x 4
↔ mm	74 x 38 x 20
Stk./g	2 x 30



# - DF / DM	421558
↙↑ mm	275 x 135 x 24
Stückzahl / pcs.	2 x 8
↔ mm	50 x 24 x 12
Stk./g	2 x 8



#	421540
↙↑ mm	275 x 135 x 24
Stückzahl / pcs.	3 x 7
↔ mm	34 x 34 x 5
Stk./g	4,35



#	422431
↙↑ mm	275 x 175 x 24
Stückzahl / pcs.	4 x 7
↔ mm	34,5 x 34,5 x 4,5
Stk./g	4,5



#	421877
↙↑ mm	275 x 135 x 24
Stückzahl / pcs.	3 x 7
↔ mm	27 x 27 x 16
Stk./g	12



#	421880
↙↑ mm	275 x 135 x 24
Stückzahl / pcs.	3 x 8
↔ mm	20 x 20 x 19
Stk./g	6,9



#	421901
↙↑ mm	275 x 135 x 24
Stückzahl / pcs.	3 x 7
↔ mm	31,5 x 31,5 x 5
Stk./g	5



# - DF / DM	421919
↙↑ mm	275 x 135 x 24
Stückzahl / pcs.	7 x 9
↔ mm	19 x 9 x 4
Stk./g	2 x 0,6

DE	FIGUREN
EN	FIGURES
IT	FIGURE
ES	FIGURAS



#	421006
↔ ↑ mm	275 x 135 x 24
Stückzahl / pcs.	3 x 8
↔ mm	38 x 27 x 16
Stk./g	15



#	421411
↔ ↑ mm	275 x 135 x 24
Stückzahl / pcs.	3 x 5
↔ mm	50 x 35 x 12
Stk./g	12



# - DF / DM	421666
↔ ↑ mm	275 x 135 x 24
Stückzahl / pcs.	3 x 8
↔ mm	26 x 19 x 27
Stk./g	7 + 9



# - DF / DM	421727
↔ ↑ mm	275 x 135 x 24
Stückzahl / pcs.	3 x 6
↔ mm	37,5 x 32 x 12,5
Stk./g	2 x 7,5



# - DF / DM	421874
↔ ↑ mm	275 x 135 x 24
Stückzahl / pcs.	3 x 6
↔ mm	36,5 x 34
Stk./g	9 + 7,5



#	421129
↔ ↑ mm	275 x 135 x 24
Stückzahl / pcs.	2 x 5
↔ mm	66 x 45 x 14
Stk./g	20



#	421746
↔ ↑ mm	275 x 135 x 24
Stückzahl / pcs.	3 x 5 / 5 Fig.
↔ mm	unterschiedlich
Stk./g	12



# - DF / DM	421931
↔ ↑ mm	275 x 135 x 24
Stückzahl / pcs.	1 x 4
↔ mm	80 x 69 x 16,5
Stk./g	2 x 34



# - DF / DM	421933
↔ ↑ mm	275 x 135 x 24
Stückzahl / pcs.	2 x 6
↔ mm	45 x 39,5 x 9,5
Stk./g	2 x 6



#	421934
↔ ↑ mm	275 x 135 x 24
Stückzahl / pcs.	1 x 4 / 4 Fig.
↔ mm	unterschiedlich
Stk./g	20



# - DF / DM	421938
↔ ↑ mm	275 x 135 x 24
Stückzahl / pcs.	2 x 7
↔ mm	37,5 x 30 x 12
Stk./g	2 x 7,5

DE	HOBBYS
EN	HOBBIES
IT	HOBBY
ES	HOBBIES



# - DF / DM	421423
↙↑ mm	275 x 135 x 35
Stückzahl / pcs.	2 x 4
↔ mm	60 x 60 x 30
Stk./g	2 x 35



# - DF / DM	421428
↙↑ mm	275 x 135 x 24
Stückzahl / pcs.	4 x 8
↔ mm	26 x 26 x 13
Stk./g	2 x 6



# - DF / DM	421443
↙↑ mm	275 x 135 x 24
Stückzahl / pcs.	3 x 8
↔ mm	30 x 30 x 15
Stk./g	2 x 8,5



# - DF / DM	421674
↙↑ mm	275 x 135 x 24
Stückzahl / pcs.	2 x 4
↔ mm	61 x 45 x 10
Stk./g	2 x 10



# - DF / DM	421224
↙↑ mm	275 x 135 x 24
Stückzahl / pcs.	3 x 9
↔ mm	30 x 24 x 11
Stk./g	2 x 7

DE	BUCHSTABEN
EN	LETTERS
IT	LETTERE
ES	LETRAS



#	421628
↙↑ mm	275 x 135 x 24
Stückzahl / pcs.	3 x 8 / 24 Fig.
↔ mm	26 x 26 x 18,5
Stk./g	12



#	421643
↙↑ mm	275 x 135 x 24
Stückzahl / pcs.	4 x 8 / 26 Fig.
↔ mm	29 x 25 x 9
Stk./g	-

DE	KEKSE
EN	BISCUITS
IT	BISCOTTINI
ES	GALLETAS



#	421357
↔ ↑ mm	275 x 135 x 24
Stückzahl / pcs.	3 x 8
↔ mm	30 x 30 x 7
Stk./g	5



#	421456
↔ ↑ mm	275 x 135 x 24
Stückzahl / pcs.	3 x 6
↔ mm	39 x 39 x 5
Stk./g	9

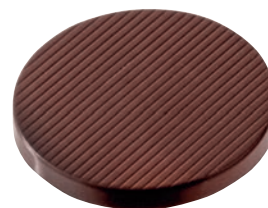

#	422054
↔ ↑ mm	275 x 175 x 24
Stückzahl / pcs.	4 x 6
↔ mm	36 x 36 x 4
Stk./g	5

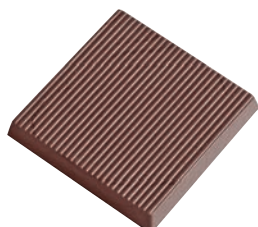

#	422360
↔ ↑ mm	275 x 175 x 24
Stückzahl / pcs.	3 x 6
↔ mm	33 x 33 x 5
Stk./g	6



# - DF / DM	421597
↔ ↑ mm	275 x 135 x 24
Stückzahl / pcs.	2 x 6 / 6 Fig.
↔ mm	36 x 28 x 9
Stk./g	2 x 6



#	421321
↔ ↑ mm	275 x 135 x 24
Stückzahl / pcs.	3 x 8
↔ mm	27 x 27 x 6
Stk./g	3



#	421795
↔ ↑ mm	275 x 135 x 24
Stückzahl / pcs.	3 x 8
↔ mm	25 x 25 x 7
Stk./g	3,5



#	421847
↔ ↑ mm	275 x 135 x 24
Stückzahl / pcs.	3 x 7
↔ mm	35 x 35 x 9
Stk./g	6



#	421865
↔ ↑ mm	275 x 135 x 24
Stückzahl / pcs.	3 x 8
↔ mm	25,5 x 25,5 x 15
Stk./g	9



#	421853
↔ ↑ mm	275 x 135 x 24
Stückzahl / pcs.	3 x 7
↔ mm	28,5 x 28,5 x 5
Stk./g	4,4

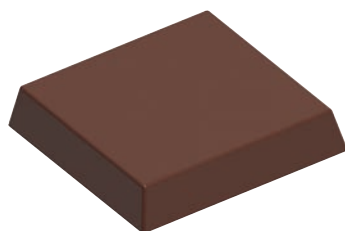

#	421887
↔ ↑ mm	275 x 135 x 24
Stückzahl / pcs.	3 x 7
↔ mm	30,5 x 30,5 x 5,6
Stk./g	5,7

DE	FANTASIE
EN	FANTASY
IT	FANTASIA
ES	FANTASÍA

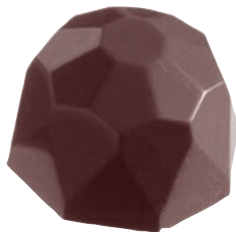

#	421024
↔ ↑ mm	275 x 135 x 24
Stückzahl / pcs.	3 x 7
↔ mm	31 x 31 x 20
Stk./g	15



#	421025
↔ ↑ mm	275 x 135 x 24
Stückzahl / pcs.	3 x 8
↔ mm	36 x 22 x 20
Stk./g	15



#	421031
↔ ↑ mm	275 x 135 x 26
Stückzahl / pcs.	3 x 8
↔ mm	37 x 23 x 20
Stk./g	17



#	421036
↔ ↑ mm	275 x 135 x 24
Stückzahl / pcs.	3 x 8
↔ mm	29 x 29 x 20
Stk./g	17



#	421045
↔ ↑ mm	275 x 135 x 24
Stückzahl / pcs.	3 x 8
↔ mm	30 x 27 x 19
Stk./g	13



#	421081
↔ ↑ mm	275 x 135 x 32
Stückzahl / pcs.	3 x 7
↔ mm	32 x 32 x 28
Stk./g	22



#	421082
↔ ↑ mm	275 x 135 x 24
Stückzahl / pcs.	3 x 10
↔ mm	35 x 20 x 17
Stk./g	14



#	421094
↔ ↑ mm	275 x 135 x 28
Stückzahl / pcs.	3 x 8
↔ mm	31 x 31 x 22
Stk./g	15

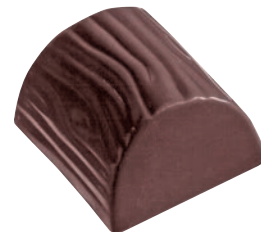

#	421189
↔ ↑ mm	275 x 135 x 24
Stückzahl / pcs.	3 x 8
↔ mm	30 x 27 x 16
Stk./g	12



#	421263
↔ ↑ mm	275 x 135 x 24
Stückzahl / pcs.	3 x 7
↔ mm	37 x 27 x 15
Stk./g	15



#	421301
↔ ↑ mm	275 x 135 x 24
Stückzahl / pcs.	3 x 8
↔ mm	30 x 30 x 16
Stk./g	10



#	421397
↔ ↑ mm	275 x 135 x 24
Stückzahl / pcs.	3 x 8
↔ mm	29 x 25 x 19
Stk./g	13

DE	FANTASIE
EN	FANTASY
IT	FANTASIA
ES	FANTASÍA



#	421533
↔↑ mm	275 x 135 x 24
Stückzahl / pcs.	1 x 10
↔ mm	11,5 x 24 x 13
Stk./g	9



#	421638
↔↑ mm	275 x 135 x 24
Stückzahl / pcs.	2 x 7
↔ mm	48 x 29 x 15
Stk./g	9,8

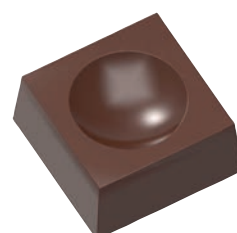

#	421647
↔↑ mm	275 x 135 x 24
Stückzahl / pcs.	3 x 8
↔ mm	26 x 26 x 12
Stk./g	9



# – DF / DM	421673
↔↑ mm	275 x 135 x 24
Stückzahl / pcs.	2 x 8
↔ mm	45,5 x 25 x 12,5
Stk./g	2 x 10



#	421676
↔↑ mm	275 x 135 x 26
Stückzahl / pcs.	4 x 8
↔ mm	22,5 x 22,5 x 19,5
Stk./g	11,5



#	422169
↔↑ mm	275 x 175 x 26
Stückzahl / pcs.	5 x 8
↔ mm	28 x 28 x 24
Stk./g	13



#	421760
↔↑ mm	275 x 135 x 30
Stückzahl / pcs.	3 x 7
↔ mm	27 x 27 x 22
Stk./g	8



#	421779
↔↑ mm	275 x 135 x 24
Stückzahl / pcs.	3 x 5
↔ mm	38,5 x 22,5 x 17,5
Stk./g	12,5



#	421781
↔↑ mm	275 x 135 x 24
Stückzahl / pcs.	2 x 7
↔ mm	42,5 x 31 x 18,5
Stk./g	10,5



#	421784
↔↑ mm	275 x 135 x 24
Stückzahl / pcs.	3 x 8
↔ mm	48 x 16,5 x 13,5
Stk./g	8



#	421794
↔↑ mm	275 x 135 x 30
Stückzahl / pcs.	3 x 8
↔ mm	26 x 26 x 25,5
Stk./g	12,5

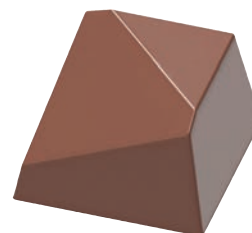

#	421799
↔↑ mm	275 x 135 x 24
Stückzahl / pcs.	3 x 7
↔ mm	27,6 x 27,6 x 17,2
Stk./g	12,5

DE	FANTASIE
EN	FANTASY
IT	FANTASIA
ES	FANTASÍA

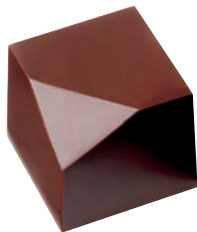

#	421840
↙↑ mm	275 x 135 x 30
Stückzahl / pcs.	3 x 8
↔ mm	23 x 23 x 20
Stk./g	12



#	421848
↙↑ mm	275 x 135 x 24
Stückzahl / pcs.	3 x 7
↔ mm	50 x 25 x 15
Stk./g	7,5



#	421859
↙↑ mm	275 x 135 x 26
Stückzahl / pcs.	3 x 7
↔ mm	24,5 x 23,5 x 21,5
Stk./g	9



#	421866
↙↑ mm	275 x 135 x 24
Stückzahl / pcs.	3 x 8
↔ mm	30,5 x 19 x 17
Stk./g	9,5



#	421858
↙↑ mm	275 x 135 x 24
Stückzahl / pcs.	3 x 7
↔ mm	32,5 x 28,5 x 15,5
Stk./g	9,5



#	421883
↙↑ mm	275 x 135 x 24
Stückzahl / pcs.	1 x 7
↔ mm	100 x 30 x 20
Stk./g	28



#	421885
↙↑ mm	275 x 135 x 24
Stückzahl / pcs.	3 x 8
↔ mm	26 x 26 x 16
Stk./g	12

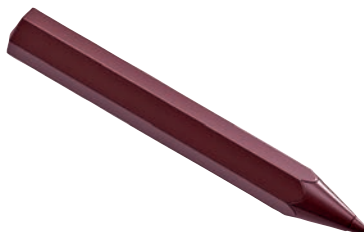

# - DF / DM	421622
↙↑ mm	275 x 135 x 24
Stückzahl / pcs.	2 x 5
↔ mm	117 x 15 x 6,5
Stk./g	2 x 9,5



#	421903
↙↑ mm	275 x 135 x 24
Stückzahl / pcs.	3 x 7
↔ mm	45,5 x 28,5 x 14
Stk./g	7,5



#	421904
↙↑ mm	275 x 135 x 24
Stückzahl / pcs.	3 x 7
↔ mm	42 x 31 x 16
Stk./g	8



#	421028
↙↑ mm	275 x 135 x 24
Stückzahl / pcs.	3 x 8
↔ mm	33 x 27 x 19
Stk./g	15



#	421092
↙↑ mm	275 x 135 x 24
Stückzahl / pcs.	3 x 8
↔ mm	39 x 28 x 17
Stk./g	15

DE	FANTASIE
EN	FANTASY
IT	FANTASIA
ES	FANTASÍA



#	421156
↔ ↑ mm	275 x 135 x 24
Stückzahl / pcs.	5 x 6
↔ mm	37 x 18 x 14
Stk./g	11



#	421173
↔ ↑ mm	275 x 135 x 24
Stückzahl / pcs.	3 x 8
↔ mm	48 x 18 x 20
Stk./g	13

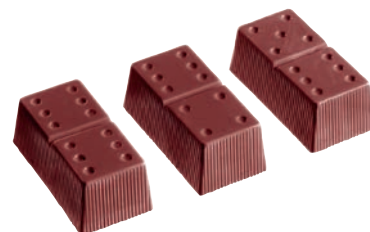

#	421330
↔ ↑ mm	275 x 135 x 24
Stückzahl / pcs.	3 x 8
↔ mm	41 x 21 x 15
Stk./g	14



#	421419
↔ ↑ mm	275 x 135 x 24
Stückzahl / pcs.	3 x 8
↔ mm	31 x 24 x 13
Stk./g	10



#	421479
↔ ↑ mm	275 x 135 x 24
Stückzahl / pcs.	4 x 5
↔ mm	48 x 29 x 11
Stk./g	19

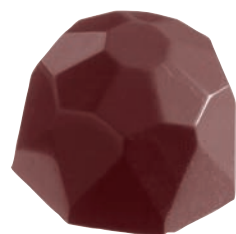

#	421521
↔ ↑ mm	275 x 135 x 24
Stückzahl / pcs.	3 x 8
↔ mm	28,5 x 28,5 x 18
Stk./g	10



#	421544
↔ ↑ mm	275 x 135 x 24
Stückzahl / pcs.	4 x 7
↔ mm	27 x 27 x 16
Stk./g	8,65



#	421545
↔ ↑ mm	275 x 135 x 24
Stückzahl / pcs.	4 x 7
↔ mm	27 x 24 x 17
Stk./g	8,75

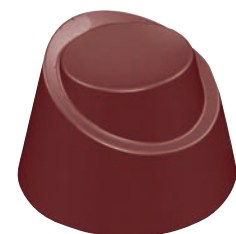

#	421555
↔ ↑ mm	275 x 135 x 24
Stückzahl / pcs.	3 x 7
↔ mm	29,5 x 29,5 x 20,2
Stk./g	12,3

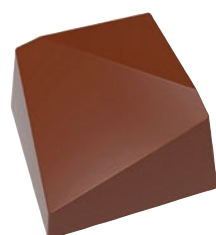

#	421559
↔ ↑ mm	275 x 135 x 24
Stückzahl / pcs.	3 x 8
↔ mm	24,4 x 24,4 x 14,5
Stk./g	7,8



#	421564
↔ ↑ mm	275 x 135 x 24
Stückzahl / pcs.	3 x 7
↔ mm	31 x 31 x 15,4
Stk./g	12,35



#	421575
↔ ↑ mm	275 x 135 x 24
Stückzahl / pcs.	3 x 7
↔ mm	29 x 29 x 20
Stk./g	5,5

DE	FANTASIE
EN	FANTASY
IT	FANTASIA
ES	FANTASÍA



#	421617
↙↑ mm	275 x 135 x 24
Stückzahl / pcs.	5 x 5
↔ mm	39 x 18 x 15,5
Stk./g	10

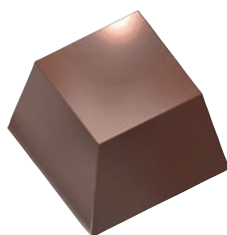

#	421630
↙↑ mm	275 x 135 x 24
Stückzahl / pcs.	3 x 8
↔ mm	26 x 26 x 18,5
Stk./g	12



#	421646
↙↑ mm	275 x 135 x 24
Stückzahl / pcs.	3 x 8
↔ mm	34,5 x 24,5 x 13
Stk./g	10



#	421753
↙↑ mm	275 x 135 x 24
Stückzahl / pcs.	3 x 7
↔ mm	27 x 27 x 19
Stk./g	11



#	421754
↙↑ mm	275 x 135 x 28
Stückzahl / pcs.	3 x 6
↔ mm	38 x 32 x 22,5
Stk./g	10



#	421764
↙↑ mm	275 x 135 x 32
Stückzahl / pcs.	3 x 7
↔ mm	31 x 31 x 27
Stk./g	9



#	421780
↙↑ mm	275 x 135 x 24
Stückzahl / pcs.	3 x 7
↔ mm	46 x 28 x 21
Stk./g	8,47



#	421782
↙↑ mm	275 x 135 x 30
Stückzahl / pcs.	3 x 6
↔ mm	44,5 x 32 x 22,5
Stk./g	11

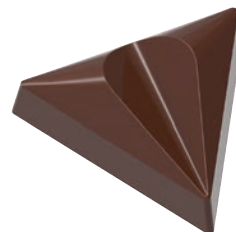

#	421905
↙↑ mm	275 x 135 x 24
Stückzahl / pcs.	3 x 7
↔ mm	39,5 x 34,5 x 13,5
Stk./g	8,5



#	421906
↙↑ mm	275 x 135 x 24
Stückzahl / pcs.	1 x 2
↔ mm	103,5 x 89,5 x 13,5
Stk./g	56



#	421908
↙↑ mm	275 x 135 x 24
Stückzahl / pcs.	1 x 7
↔ mm	113 x 28 x 11
Stk./g	31,5



#	421911
↙↑ mm	275 x 135 x 24
Stückzahl / pcs.	2 x 6 / 3 Fig.
↔ mm	unterschiedlich
Stk./g	5,5

DE	FANTASIE
EN	FANTASY
IT	FANTASIA
ES	FANTASÍA



# - DF / DM	421912
↔ ↑ mm	275 x 135 x 24
Stückzahl / pcs.	3 x 6
↔ mm	39 x 34 x 7
Stk./g	2 x 5,5

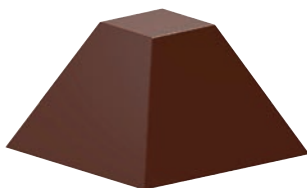

#	421915
↔ ↑ mm	275 x 135 x 24
Stückzahl / pcs.	3 x 7
↔ mm	27,5 x 27,5 x 17
Stk./g	8



# - DF / DM	421916
↔ ↑ mm	275 x 135 x 24
Stückzahl / pcs.	1 x 14
↔ mm	120 x 9,5 x 5
Stk./g	2 x 4,8



#	421921
↔ ↑ mm	275 x 135 x 24
Stückzahl / pcs.	3 x 7
↔ mm	36,5 x 27,5 x 16,5
Stk./g	10,5

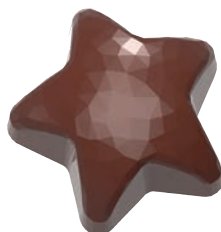

#	421922
↔ ↑ mm	275 x 135 x 24
Stückzahl / pcs.	3 x 7
↔ mm	35,5 x 35,5 x 17
Stk./g	12



#	421923
↔ ↑ mm	275 x 135 x 30
Stückzahl / pcs.	3 x 8
↔ mm	26,5 x 26,5 x 22
Stk./g	9,5



#	421924
↔ ↑ mm	275 x 135 x 32
Stückzahl / pcs.	3 x 7
↔ mm	31 x 31 x 26,5
Stk./g	9,5



#	421929
↔ ↑ mm	275 x 135 x 24
Stückzahl / pcs.	1 x 10
↔ mm	99,5 x 19,5 x 11,5
Stk./g	17,5



#	421930
↔ ↑ mm	275 x 135 x 24
Stückzahl / pcs.	3 x 8
↔ mm	36 x 20 x 15
Stk./g	9,5



#	421932
↔ ↑ mm	275 x 135 x 28
Stückzahl / pcs.	3 x 7
↔ mm	28 x 28 x 24
Stk./g	13,5



#	421935
↔ ↑ mm	275 x 135 x 24
Stückzahl / pcs.	3 x 7
↔ mm	35 x 31 x 16,5
Stk./g	11



#	421936
↔ ↑ mm	275 x 135 x 24
Stückzahl / pcs.	1 x 4
↔ mm	117,5 x 49,5 x 9
Stk./g	57

DE	FANTASIE
EN	FANTASY
IT	FANTASIA
ES	FANTASÍA

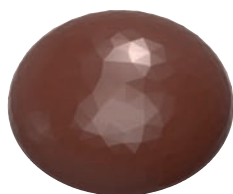

# - DF / DM	421939
↔ ↑ mm	275 x 135 x 24
Stückzahl / pcs.	3 x 7
↔ → mm	35 x 35 x 8,5
Stk./g	2 x 7

#	422371
↔ ↑ mm	275 x 175 x 24
Stückzahl / pcs.	4 x 9 / 6 Fig.
↔ → mm	unterschiedlich
Stk./g	6 / 7



DE	TASSEN
EN	CUPS
IT	TAZZE
ES	TAZAS



#	421002
↔ ↑ mm	275 x 135 x 24
Stückzahl / pcs.	3 x 7
↔ mm	30 x 30 x 19
Stk./g	14



#	421003
↔ ↑ mm	275 x 135 x 24
Stückzahl / pcs.	3 x 8
↔ mm	35 x 26 x 19
Stk./g	14



#	421342
↔ ↑ mm	275 x 135 x 32
Stückzahl / pcs.	4 x 8
↔ mm	28 x 28 x 27
Stk./g	17



#	421387
↔ ↑ mm	275 x 135 x 24
Stückzahl / pcs.	3 x 8
↔ mm	30 x 30 x 20
Stk./g	11



#	421585
↔ ↑ mm	275 x 135 x 24
Stückzahl / pcs.	3 x 8
↔ mm	26 x 33 x 14,5
Stk./g	7



12

DE	KUGELN
EN	SPHERES
IT	SFERE
ES	ESFERAS



# - DF / DM	421158
↔ ↑ mm	275 x 135 x 24
Stückzahl / pcs.	4 x 9
↔ mm	25 x 25 x 12,5
Stk./g	2 x 4



# - DF / DM	421217
↔ ↑ mm	275 x 135 x 24
Stückzahl / pcs.	3 x 8
↔ mm	30 x 30 x 15
Stk./g	2 x 9



# - DF / DM	421258
↔ ↑ mm	275 x 135 x 24
Stückzahl / pcs.	4 x 8
↔ mm	27 x 27 x 13,5
Stk./g	2 x 6

DE	KUGELN
EN	SPHERES
IT	SFERE
ES	ESFERAS



# - DF / DM	421495
↔ ↑ mm	275 x 135 x 24
Stückzahl / pcs.	4 x 10
↔ mm	20 x 20 x 10
Stk./g	2 x 2,5



# - DF / DM	421648
↔ ↑ mm	275 x 135 x 30
Stückzahl / pcs.	2 x 4
↔ mm	50 x 50 x 25
Stk./g	2 x 38



# - DF / DM	422361
↔ ↑ mm	275 x 175 x 24
Stückzahl / pcs.	5 x 8
↔ mm	27 x 27 x 13
Stk./g	2 x 6



# - DF / DM	421797
↔ ↑ mm	275 x 135 x 24
Stückzahl / pcs.	6 x 13
↔ mm	14 x 14 x 7
Stk./g	2 x 1



#	421157
↔ ↑ mm	275 x 135 x 30
Stückzahl / pcs.	3 x 7
↔ mm	29,7 x 29,7 x 25
Stk./g	16,8



# - DF / DM	422252
↔ ↑ mm	275 x 175 x 35
Stückzahl / pcs.	8 x 1
↔ mm	59 x 59 x 29
Stk./g	2 x 71



#	421291
↔ ↑ mm	275 x 135 x 40
Stückzahl / pcs.	1 x 14
↔ mm	45 x 45 x 38
Stk./g	44



#	421292
↔ ↑ mm	275 x 135 x 35
Stückzahl / pcs.	3 x 7
↔ mm	35 x 35 x 30
Stk./g	25



# - DF / DM	422022
↔ ↑ mm	275 x 175 x 24
Stückzahl / pcs.	5 x 8
↔ mm	30 x 30 x 15
Stk./g	2 x 9



#	422116
↔ ↑ mm	275 x 175 x 28
Stückzahl / pcs.	4 x 8
↔ mm	29 x 29 x 23
Stk./g	14



# - DF / DM	422251
↔ ↑ mm	275 x 175 x 30
Stückzahl / pcs.	12 x 1
↔ mm	50 x 50 x 25
Stk./g	2 x 40

DE	KUGELN
EN	SPHERES
IT	SFERE
ES	ESFERAS



# - DF / DM	422253
↙↑ mm	275 x 175 x 40
Stückzahl / pcs.	2 x 3
↔ mm	70 x 70 x 35
Stk./g	2 x 113



# - DF / DM	422254
↙↑ mm	275 x 175 x 40
Stückzahl / pcs.	2 x 3
↔ mm	80 x 80 x 40
Stk./g	2 x 162



#	422295
↙↑ mm	275 x 175 x 24
Stückzahl / pcs.	4 x 8
↔ mm	29 x 29 x 21
Stk./g	13



# - DF / DM	421909
↙↑ mm	275 x 135 x 24
Stückzahl / pcs.	3 x 8
↔ mm	25 x 25 x 12,5
Stk./g	2 x 5



#	421867
↙↑ mm	275 x 135 x 30
Stückzahl / pcs.	3 x 8
↔ mm	25,5 x 25,5 x 22,5
Stk./g	9,5



12

DE	BOUCHÉS & BLÖCKE
EN	BOUCHÉS & BLOCS
IT	CIOCCOLATINI RIPIENI E TAVOLETTE
ES	BOMBONES RELLENOS Y BARRAS DE CHOCOLATE



#	421367
↙↑ mm	275 x 135 x 24
Stückzahl / pcs.	1 x 5
↔ mm	117 x 50 x 11
Stk./g	84



#	421421
↙↑ mm	275 x 135 x 24
Stückzahl / pcs.	1 x 3
↔ mm	130 x 79 x 9
Stk./g	105



#	421431
↙↑ mm	275 x 135 x 24
Stückzahl / pcs.	1 x 3
↔ mm	124 x 77 x 11
Stk./g	102

DE	BOUCHÉS & BLÖCKE
EN	BOUCHÉS & BLOCS
IT	CIOCCOLATINI RIPIENI E TAVOLETTE
ES	BOMBONES RELLENOS Y BARRAS DE CHOCOLATE



#	421588
↖↗ mm	275 x 135 x 24
Stückzahl / pcs.	3 x 3
↔ mm	67 x 33 x 5
Stk./g	12

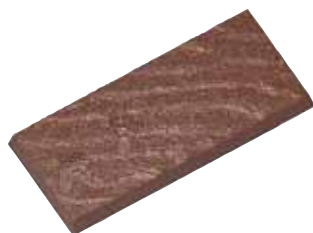

#	421665
↖↗ mm	275 x 135 x 24
Stückzahl / pcs.	1 x 4
↔ mm	118 x 53 x 9,5
Stk./g	61



#	421132
↖↗ mm	275 x 135 x 24
Stückzahl / pcs.	1 x 7
↔ mm	125 x 30 x 13
Stk./g	50



#	421256
↖↗ mm	275 x 135 x 24
Stückzahl / pcs.	1 x 7
↔ mm	128 x 29 x 14
Stk./g	47



#	421611
↖↗ mm	275 x 135 x 24
Stückzahl / pcs.	4 x 2
↔ mm	123 x 22 x 6
Stk./g	16,5



#	421745
↖↗ mm	275 x 135 x 24
Stückzahl / pcs.	2 x 5
↔ mm	63 x 18 x 8
Stk./g	10



#	421667
↖↗ mm	275 x 135 x 24
Stückzahl / pcs.	2 x 2
↔ mm	125 x 55 x 7
Stk./g	47



#	421796
↖↗ mm	275 x 135 x 24
Stückzahl / pcs.	1 x 5
↔ mm	105 x 45 x 7,5
Stk./g	26



#	421854
↖↗ mm	275 x 135 x 24
Stückzahl / pcs.	1 x 8
↔ mm	117,5 x 25 x 14,5
Stk./g	32



#	421872
↖↗ mm	275 x 135 x 24
Stückzahl / pcs.	1 x 8
↔ mm	116,5 x 22,5 x 15
Stk./g	37,7



#	421898
↖↗ mm	275 x 135 x 24
Stückzahl / pcs.	1 x 3
↔ mm	79,5 x 79,5 x 13,5
Stk./g	77,5



#	421899
↖↗ mm	275 x 135 x 24
Stückzahl / pcs.	1 x 8
↔ mm	117,5 x 23,5 x 14
Stk./g	36,5

DE	BOUCHÉS & BLÖCKE
EN	BOUCHÉS & BLOCS
IT	CIOCCOLATINI RIPIENI E TAVOLETTE
ES	BOMBONES RELLENOS Y BARRAS DE CHOCOLATE



#	421612
↔ ↑ mm	275 x 135 x 24
Stückzahl / pcs.	2 x 2
↔ mm	114 x 50 x 8
Stk./g	55



#	421642
↔ ↑ mm	275 x 135 x 24
Stückzahl / pcs.	1 x 2
↔ mm	100 x 100 x 15
Stk./g	92



#	421685
↔ ↑ mm	275 x 135 x 24
Stückzahl / pcs.	1 x 2
↔ mm	100 x 100 x 8
Stk./g	75



#	421769
↔ ↑ mm	275 x 135 x 24
Stückzahl / pcs.	2 x 2
↔ mm	124,5 x 55,5 x 6,5
Stk./g	45



#	422110
↔ ↑ mm	275 x 175 x 24
Stückzahl / pcs.	1 x 3
↔ mm	156 x 77 x 8
Stk./g	90



#	422162
↔ ↑ mm	275 x 175 x 24
Stückzahl / pcs.	1 x 3
↔ mm	155 x 77 x 9
Stk./g	108



#	422276
↔ ↑ mm	275 x 175 x 30
Stückzahl / pcs.	1 x 1
↔ mm	250 x 160 x 25
Stk./g	1000



#	422436
↔ ↑ mm	275 x 175 x 24
Stückzahl / pcs.	1 x 3
↔ mm	156 x 77 x 4
Stk./g	50



#	422437
↔ ↑ mm	275 x 175 x 24
Stückzahl / pcs.	1 x 3
↔ mm	156 x 77 x 5
Stk./g	60



#	422438
↔ ↑ mm	275 x 175 x 24
Stückzahl / pcs.	1 x 3
↔ mm	156 x 77 x 6
Stk./g	70



DE	MEERESFRÜCHTE
EN	SEAFRUIT
IT	FRUTTI DI MARE
ES	MARISCOS



#	421084
↖ mm	275 x 135 x 24
Stückzahl / pcs.	3 x 8
↔ mm	35 x 29 x 21
Stk./g	15



#	421170
↖ mm	275 x 135 x 24
Stückzahl / pcs.	4 x 7 / 5 Fig.
↔ mm	38 x 20 x 7
Stk./g	4,5



# - DF / DM	421586
↖ mm	275 x 135 x 24
Stückzahl / pcs.	22 x 1 / 9 Fig.
↔ mm	unterschiedlich
Stk./g	2 x 6

DE	LOLLIES
EN	LOLLIES
IT	LECCA LECCA
ES	PIRULETAS



#	421294
↖ mm	275 x 135 x 24
Stückzahl / pcs.	1 x 10
↔ mm	66 x 35 x 10
Stk./g	16



#	421354
↖ mm	275 x 135 x 24
Stückzahl / pcs.	1 x 6
↔ mm	48 x 37 x 15
Stk./g	11



#	421480
↖ mm	275 x 135 x 24
Stückzahl / pcs.	1 x 4
↔ mm	54 x 63 x 12
Stk./g	29



#	421623
↖ mm	275 x 135 x 24
Stückzahl / pcs.	1 x 4
↔ mm	49,5 x 49,5 x 11
Stk./g	16,5



#		
450900	500 Stk.	



DE	STÄBCHEN AUS PAPPE
EN	STICKS, MADE OF CARDBOARD
IT	BASTONCINI IN CARTONE
ES	PALITOS DE CARTÓN

#	↗ mm		
115548	120	50	



DE	MAGNETFORMEN
EN	MAGNET MOULDS
IT	STAMPI MAGNETICI
ES	MOLDES DE IMÁN

Das Gewicht wurde auf der Grundlage von Vollmilch-Schokolade bestimmt und kann je nach Schokoladensorte, der Füllung sowie der Gießtechnik, Abweichungen verzeichnen.

Il peso viene determinato in base a cioccolato al latte e può subire variazioni secondo il tipo di cioccolato impiegato, il ripieno e la tecnica di fusione.

The weight is based on a moulding with solid milk chocolate and may depend on your chocolate, filling and way of moulding.

El peso queda determinado a base de chocolate con leche entera y puede ser distinto según el tipo de chocolate, relleno y técnica de moldeo.

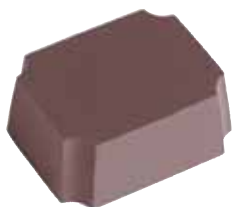

#	430000
↔ ↑ mm	275 x 135 x 24
Stückzahl / pcs.	3 x 5
↔ mm	35 x 28 x 14
Stk./g	13,5

#	430001
↔ ↑ mm	275 x 135 x 24
Stückzahl / pcs.	4 x 6
↔ mm	24 x 24 x 14
Stk./g	9,5

#	430007
↔ ↑ mm	275 x 135 x 24
Stückzahl / pcs.	3 x 6
↔ mm	32 x 24 x 11
Stk./g	9



#	430008
↔ ↑ mm	275 x 135 x 24
Stückzahl / pcs.	3 x 4
↔ mm	46 x 40 x 15
Stk./g	13



**Das Edhard-System beinhaltet 3 Hauptkomponenten:  
 Motorblock, Trichter mit Pumpeneinheit und Dosiertülle.**

Edhard Dosiermaschine / Gebäckfüller zum automatischen Befüllen, Dosieren und Dekorieren von Gebäck und Lebensmitteln aller Art wie z.B. Teig, Butter, Käsekuchen, Hüttenkäse, Frischkäse, Sahne, Cremes, Früchtefüllungen, Honig, Glasuren, Gelee, Ketchup, Sirup, Senf, Pudding, Püree, Salat-Dressing, Joghurt und viele andere Produkte.

**This equipment consists of three main components:  
 Power base, filler unit (pump and hopper) and the spouts.**

Automatic dosingmeter for injecting, depositing, layering and topping. A partial list of food products using the dosing systems: Dough, butter, cheesecake, cottage cheese, cream cheese, creams, custard, fruit fillings, honey, icing, jelly, ketchup, molasses, mustard, pudding, purees, salad dressing, yogurt and many other products.



**i** 1 Set = 1 x # 152600 / 1 x # 152611 / 2 x # 152661

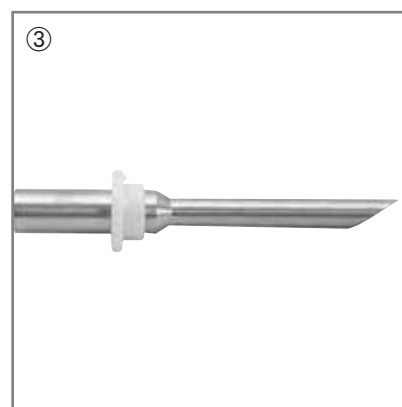

# edhard



INOX

13

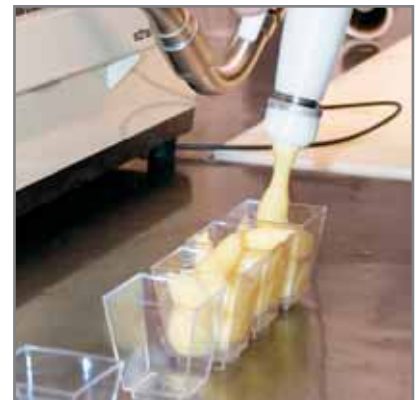

DE	DOSIERMASCHINE "EDHARD"
EN	DOSINGMETER "EDHARD"
IT	DOSATRICE "EDHARD"
ES	DOSIFICADORA "EDHARD"

Zum automatischen Füllen von Croissants, Donuts und Gebäckstücken jeder Art

- Sehr leicht zu bedienen, leicht zu reinigen
- Dosiermenge über digitales Bedienfeld einstellbar
- Kein Tropfen, da gegenläufiger Arbeitsablauf

For stuffing croissant, donuts and all kinds of pastries

- Very simple to use, easy to clean
- Quantity to be dispensed is adjustable with a digital entry keypad from 0 to 99
- No dripping because of reverse motion at end of fill cycle

#	152600	152840	152609	152845
	<b>44 Watt</b>	<b>93 Watt</b>	<b>186 Watt</b>	<b>186 Watt</b>
	Automatischer Zyklus / automatic cycle	Automatischer Zyklus / automatic cycle	Motor mit einstellbarer Geschwindigkeit, Geschwindigkeitskontrolle, Rücklauf und automatischem Zyklus / power base with variable speed, speed control, reverse and automatic cycle	Motor mit einstellbarer Geschwindigkeit, Geschwindigkeitskontrolle, Rücklauf und automatischem Zyklus / power base with variable speed, speed control, reverse and automatic cycle
↔ mm	172 x 391 x 229	241 x 391 x 229	241 x 391 x 229	300 x 400 x 225
	Motor / power base	Motor / power base	Motor / power base	Motor / power base
	220 Volt	240 Volt	240 Volt	240 Volt
 kg	5,5 kg	8,0 kg	8,0 kg	13,3 kg



DE	TRICHTER
EN	FILLER UNITS
IT	TRAMOGGIA
ES	TOLVA-DEPOSITO



#		Ø mm	↑ mm	l	kg
152610	einfach / single	229	381	5,5	1,70
152612	einfach / single	260	502	17,0	2,32
152611	doppelt / double	229	381	5,5	1,70
152613	doppelt / double	260	502	17,0	2,32





<b>93</b> <b>186</b>	DE	TRICHTER EINFACH
	EN	HOPPERS SINGLE
	IT	TRAMOGGIA A USCITA UNICA
	ES	TOLVA-DEPOSITO UNICA SALIDA

Für # 152851 und 152856

For # 152851 und 152856

#		↓ ↑	⚖️ kg
152860	einfach / single	5,5	0,6
152861	einfach / single	17,0	1,5



<b>93</b> <b>186</b>	Material: Edelstahl	Made of stainless steel
	Für # 152851 und 152856	For # 152851 und 152856

#		↓ ↑	⚖️ kg
152862	einfach / single	17,0	4,3
152865	einfach / single	32,0	5,3

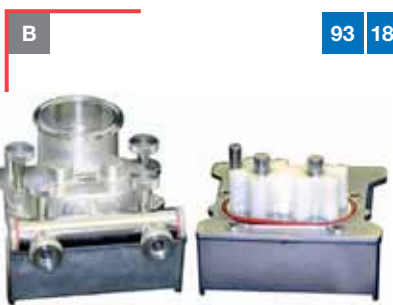

<b>93</b> <b>186</b>	DE	PUMPEINHEIT AUS EDELSTAHL FÜR FLÜSSIGE PRODUKTE
	EN	PUMP MADE OF STAINLESS STEEL FOR SMOOTH PRODUCTS
	IT	GRUPPO POMPA IN ACCIAIO INOX PER PRODOTTI LIQUIDI
	ES	BOMBA EN INOX PARA PRODUCTOS LÍQUIDOS

#		⚖️ kg
152856	Pumpeinheit doppelt / pump double	4,2



<b>93</b> <b>186</b>	DE	PUMPEINHEIT AUS EDELSTAHL FÜR PRODUKTE MIT TEILCHEN
	EN	PUMP MADE OF STAINLESS STEEL FOR PRODUCTS WITH PARTICLES
	IT	GRUPPO POMPA IN ACCIAIO INOX PER PRODOTTI GRANULOSI
	ES	BOMBA EN INOX PARA PRODUCTOS CON TROCITOS SÓLIDOS

Für Teilchen max. 10 mm

For particles of max. 10 mm

#		⚖️ kg
152851	Pumpeinheit einfach / pump single	4,0

DE	KUPPLUNGSSTÜCK FÜR TRICHTER EINFACH
EN	ADAPTER FOR SINGLE FILLER UNITS
IT	ADATTATORE A DOPPIA USCITA PER TRAMOGGIA
ES	ADAPTADOR CON DOBLE SALIDA PARA TOLVA

Zur Verwendung von „2-fach“ Tüllen bei einfachen Trichtern

For using "double spouts" for single filler units

#		für/for #	
152699	Kupplungsstück / adapter	152610, 152612, 152851	



DE	TÜLLEN-ADAPTER
EN	EXTERNAL PIPING TUBE ADAPTER
IT	ADATTATORE PER BOCCHETTE
ES	ADAPTADOR PARA BOQUILLAS

Für Verlängerungsschlauch # 152677

for hose assembly # 152677

#		Ø mm	
152710		24	
152711		30	
152712		35	





















DE	ZUBEHÖR FÜR DOSIERMASCHINE "EDHARD"
EN	ACCESSORY FOR DOSINGMETER "EDHARD"
IT	ACCESSORIO PER DOSATRICE "EDHARD"
ES	ACCESORIO PARA DOSIFICADORA "EDHARD"

#		
152679	Fußpedal / Switch foot	



DE	ZUBEHÖR FÜR DOSIERMASCHINE "EDHARD" PASSEND FÜR TRICHTER 152611, 152613, 152856
EN	ACCESSORIES FOR DOSINGMETER "EDHARD" USABLE FOR FILLER UNITS 152611, 152613, 152856
IT	ACCESSORI "EDHARD" PER TRAMOGGE 152611, 152613, 152856
ES	ACCESORIOS "EDHARD" PARA TOLVAS 152611, 152613, 152856

#		Ø mm	↗ mm
 152630	 Tülle, doppelt / Spout double	11,1	89
 152631	 Konfitüre-Tülle, doppelt / Jam spout, double	11	82,5
 152632	 Tülle glatt, doppelt / Spout plain, double	4,8	41
 152652	 Tülle geschlitzt, doppelt / Spout eclair-slit, double	11,1	127
 152653	 Tülle, doppelt / Spout, double	11,1	127
 152657	 Tülle glatt, doppelt / Spout plain, double	7,9	111,1
 152659	 Tülle geschlitzt, doppelt / Spout eclair-slit, double	7,9	111,2
 152661	 Tülle glatt 30° doppelt / Spout plain 30° double	7,1	57
 152666	 Berlinertülle, doppelt / Spout "Krapfen", double	6,4	41,3

DE	ZUBEHÖR FÜR DOSIERMASCHINE "EDHARD" PASSEND FÜR TRICHTER 152610, 152612, 152851
EN	ACCESSORIES FOR DOSINGMETER "EDHARD" USABLE FOR FILLER UNITS 152610, 152612, 152851
IT	ACCESSORI "EDHARD" PER TRAMOGGE 152610, 152612, 152851
ES	ACCESORIOS "EDHARD" PARA TOLVAS 152610, 152612, 152851

#		Ø mm	↗ mm	→ mm	
---	--	------	------	------	--

	▶A ▶C	152633	Tülle glatt, einfach / Spout plain, single	22,2	57		
---	-------	--------	--	------	----	--	--

	▶A ▶C	152635	Tülle glatt, einfach / Spout plain, single	22,2	89		
---	-------	--------	--	------	----	--	--

	▶A ▶C	152636	Tülle glatt, einfach / Spout plain, single	22,2	127		
---	-------	--------	--	------	-----	--	--

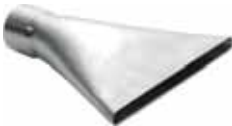
	▶A ▶C	152638	Bandtülle / Layering spout		101	7,1	
		152639	Bandtülle / Layering spout		89	4,8	
		152640	Bandtülle / Layering spout		40	4	
		152641	Bandtülle / Layering spout		40	2	
		152642	Bandtülle / Layering spout		60	3	
		152643	Bandtülle / Layering spout		50	2,5	
		152644	Bandtülle / Layering spout		70	3	
		152645	Bandtülle / Layering spout		80	2,5	
		152646	Bandtülle / Layering spout		30	3,6	







	▶A ▶C	152647	Tülle einfach 45° / Spout single 45°	22,2	120,6		
---	-------	--------	--------------------------------------	------	-------	--	--

	▶A ▶C	152648	Dreifach-Tülle einfach / Spout triple single	4,8 x 3	25	3	
---	-------	--------	--	---------	----	---	--

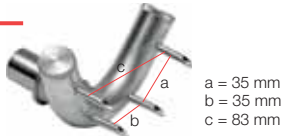
	▶A ▶C	152654	Tülle glatt, einfach / Spout plain, single	22,2	177,8	3	
---	-------	--------	--	------	-------	---	--

	▶A ▶C	152880	Donut-Füller / Donut spout	88	H: 30		
---	-------	--------	----------------------------	----	-------	--	--

DE	ZUBEHÖR FÜR DOSIERMASCHINE "EDHARD" PASSEND FÜR TRICHTER 152610, 152612, 152851
EN	ACCESSORIES FOR DOSINGMETER "EDHARD" USABLE FOR FILLER UNITS 152610, 152612, 152851
IT	ACCESSORI "EDHARD" PER TRAMOGGE 152610, 152612, 152851
ES	ACCESORIOS "EDHARD" PARA TOLVAS 152610, 152612, 152851

#		Ø mm	↗ mm	→ mm	
▶A ▶C					
152655	Tülle geschlitzt, einfach / Spout slit, single	22,2	111,2		
▶A ▶C					
152656	Croissant-Füller einfach / Croissant spout, single	4,8 x 4	25	4	
▶A ▶C					
152658	Tülle geschlitzt, einfach / Spout slit, single	22,2	127		
▶A ▶C					
152660	Tülle "Cannoli" einfach / Spout "Cannoli" single	14,3	76,2		
▶A ▶C					
152662	Tülle glatt, einfach / Spout plain, single	22,2	41		
▶A ▶C					
152663	Tülle Blaubeeren, einfach / Spout blueberry, single	22,2	82,5		
▶A ▶C					
152664	Tülle glatt, einfach / Spout plain, single	22,2	111,2		
▶A ▶C					
152665	Univers. Verläng., einf. / Univers. extension, single	22,2	158,7		

DE	ZUBEHÖR FÜR DOSIERMASCHINE "EDHARD" PASSEND FÜR TRICHTER 152610, 152612, 152851
EN	ACCESSORIES FOR DOSINGMETER "EDHARD" USABLE FOR FILLER UNITS 152610, 152612, 152851
IT	ACCESSORI "EDHARD" PER TRAMOGGE 152610, 152612, 152851
ES	ACCESORIOS "EDHARD" PARA TOLVAS 152610, 152612, 152851

#		Ø mm	↗ mm		
---	--	------	------	--	--

▶A▶C



152677	Verlängerung (Schlauch) / Hose assembly	22,2	914		
--------	---	------	-----	--	--

DE	AUSGLEICHSVORRICHTUNG
EN	BALANCER
IT	BILANCIAMENTO
ES	BALANCEADOR

Halterung für Edhard Schlauchsystem,  
integrierte Zugvorrichtung.

Holder for Edhard hose, integrated traction  
device.

#	↔ mm	
152898	380 x 410 x 135	



DE	ZUBEHÖR FÜR DOSIERMASCHINE "EDHARD"
EN	ACCESSORIES FOR DOSINGMETER "EDHARD"
IT	ACCESSORI PER DOSATRICI "EDHARD"
ES	ACCESORIOS PARA DOSIFICADORAS EDHARD

#		für/for #	Ø mm
			
152637	Ansatzstück für Art-Nr. / Double spout for code	# 152665	19
			
152669	Anti-Tropfröhre für Art-Nr. / Dripless valve for code	# 152665, 152677	
			
152670	Anti-Tropfröhre für Art-Nr. / Dripless valve for code	# 152665, 152677	
			
152671	Dekortülle für Art-Nr. / Decor tube for code	# 152665, 152677	9,7
152672	Dekortülle für Art-Nr. / Decor tube for code	# 152665, 152677	14
			
152673	Dekortülle für Art-Nr. / Decor tube for code	# 152665, 152677	14,2
152674	Dekortülle für Art-Nr. / Decor tube for code	# 152665, 152677	4,8 x 9,7
152675	Dekortülle für Art-Nr. / Decor tube for code	# 152665, 152677	12
152676	Dekortülle für Art-Nr. / Decor tube for code	# 152665, 152677	9,7

DE	GEBÄCKFÜLLER
EN	CREAM INJECTOR
IT	RIEMPITRICE PER CREME
ES	INYECTORA

- Zum Füllen von Krapfen, Pfannkuchen und anderen Patisserie-Produkten mit max. Geschwindigkeit und Genauigkeit
- Gehäuse aus Aluminiumguß
- Trichter, Zylinder, Dosierer, Welle, Hebel und Auslaufrohr aus rostfreiem Edelstahl
- For filling "Krapfen", pancakes and other sweets with maximum speed and precision
- Base made of cast aluminium
- Funnel, cylinder, piston, injector, lever and thrust rib are made of stainless steel

#### KLEIN

Technische Daten:

Auslaufrohr Ø:	2,4 mm
Dosiermenge:	1 – 30 g
Einfüllmenge:	2,0 l

#### SMALL

Technical specification:

Piston Ø:	2,4 mm
Dosis:	1 – 30 g
Funnel:	2.0 l



#	↑ mm	→ mm	kg
153000	440	250	2,70

#### GROSS

Technische Daten:

Auslaufrohr Ø:	3,1 mm;
Dosiermenge:	1 – 60 g
Einfüllmenge:	5,2 l

#### LARGE

Technical specification:

Piston Ø:	3,1 mm
Dosis:	1 – 60 g
Funnel:	5.2 l



#	↑ mm	→ mm	kg
153001	520	370	7,20

DE	GEBÄCKSPRITZE
EN	BISCUIT / PASTRY SYRINGE
IT	SIRINGA PER PASTICCERIA
ES	JERINGA PARA PASTELERÍA

- Korpus, Gebäckspritze, Griff und Füße aus Aluminium
- Inklusive 13 Scheiben für unterschiedliche Spritzgebäckarten
- Body, fittings, pastry presses, handle and bracket made of aluminium
- Including 13 different pastry presses for various shapes of biscuit pastry

#	↔ mm	kg
152700	500 x 200 x 190	5,0





# 151236  
Donut-Aufsatz / Donut adapter

DE GEBÄCKFÜLLER  
EN CREAM INJECTOR  
IT RIEMPITRICE PER CREME  
ES INYECTORA PARA CREMAS



- Füllkolben und Schüssel aus Edelstahl
- Inklusive 2 Deckel
- Dosiermenge regulierbar: 0 – 15 g
- Jedes Bauteil ist einfach zu reinigen
- Pistons and bowl made of stainless steel
- Including 2 lids
- Dosing adjustable: 0 – 15 g
- All components are easy to clean

Ø (mm)	80
Ø Nadel / needle (mm)	2
Höhe Nadel / Height needle (mm)	15
Abstand Nadel / Distance needle (mm)	20
Anzahl / quantity	8

#		↔ mm	⚖ kg	📦
152200	2 Füllkolben / 2 pistons	260 x 380 x 350	2,1	3,0
152230	1 Füllkolben / 1 piston	260 x 380 x 350	2,0	3,0
152235	mit Donut-Füllkolben / with donut filler spout	260 x 380 x 350	2,0	3,0
152210	Ersatzschüssel / bowl		–	3,0



# 152230



# 152200



# 152235



DE	HEBEL DOSIERSPENDER MIT DONUT-AUFSATZ
EN	LEVER DISPENSER WITH DONUT ADAPTER
IT	DOSATORE A LEVA CON ATTACCO PER CIAMBELLA
ES	DOSIFICADOR DE PALANCA CON ACCESORIO PARA DONUTS

Material: Edelstahl

• **Beheizbar**

- Temperatur einstellbar: 0 – 120 °C
- Spannung: 230 V, 50 Hz
- Leistung: 900 W
- Dosierung einstellbar / ± 35 ml

**Achtung: Wasserbad-Funktion**

Made of stainless steel

• **Heatable**

- Temperature adjustable: 0 – 120 °C
- Voltage: 230 V, 50 Hz
- Power: 900 W
- Dosage adjustable / ± 35 ml

**Attention: Bain-Marie Function**

#	↔ mm	⚖ kg	📦
152260	180 x 180 x 510	3,8	3,0

Material: Edelstahl

- Dosierung einstellbar / ± 35 ml

Made of stainless steel

- Dosage adjustable / ± 35 ml

#	↔ mm	⚖ kg	📦
152280	180 x 180 x 460	2,3	4,5



# 151238

Donut-Aufsatz / Donut adapter

Ø (mm)	75
Ø Nadel / needle (mm)	3
Höhe Nadel / Height needle (mm)	20
Abstand Nadel / Distance needle (mm)	20
Anzahl / quantity	8



13



DE	FLASCHENWÄRMER, ELEKTRISCH
EN	BOTTLE WARMER, ELECTRIC
IT	SCALDAFLACONI DOSATORI
ES	CALIENTA BIBERONES

- Außengehäuse Edelstahl
- Temperatur stufenlos regelbar (40–90°C)
- Kein Wasserbad – Temperatureaustausch erfolgt über Direktkontakt / Luft
- Geringer Energieverbrauch
- Inklusive Quetschflasche (950 ml) aus PP
- Öffnungsdurchmesser: 86 mm
- Öffnungstiefe: 195 mm
- Outer casing stainless steel
- Temperature infinitely variable (40–90°C)
- No bain marie – temperature exchange via direct contact / air
- Low energy consumption
- Including squeeze bottle (950 ml) made of PP
- Opening diameter: 86 mm
- Opening depth: 195 mm



# 150620



# 150630



# 150635

#	150620	150630	150635
	Flaschenwärmer 1-fach	Flaschenwärmer 2-fach	Flaschenwärmer 3-fach
	Außengehäuse Edelstahl	Außengehäuse Edelstahl	Außengehäuse Edelstahl
Zubehör	Quetschflasche 1 x 950 ml	Quetschflasche 2 x 950 ml	Quetschflasche 3 x 950 ml
→ mm	210	305	445
↓ mm	165	165	165
↑ mm	330	330	330
🔌	200 W 50 / 60 Hz / 230 Volt	400 W 50 / 60 Hz / 230 Volt	600 W 50 / 60 Hz / 230 Volt
°C	40° bis 90°C	40° bis 90°C	40° bis 90°C

DE	QUETSCHFLASCHEN	
EN	SQUEEZE BOTTLES	PP 
IT	FLACONI DOSATORI	
ES	DISPENSADORES A PRESIÓN – BIBERONES	

#	Öffnung / mouth	↑ mm	g	Ø mm	ml
150625	1 ○	281	85	80	950
150621	3 ○	291	74	80	950
200490	1 ○	195	30	52	250
200491	1 ○	240	42	62	500
200492	1 ○	265	61	72	750
200493	1 ●	240	42	62	500
200494	1 ●	265	61	72	750
200495	1 ●	240	42	62	500
200496	1 ●	265	61	72	750



# 150625 # 150621



DE	DOSIERSYSTEM	
EN	DOSING SYSTEM	PP 
IT	SISTEMA DI DOSAGGIO	
ES	SISTEMA DE DOSIFICACIÓN	

- Geeignet für alle Arten von Saucen, Senf, Ketchup, Mayonnaise
- Zur Befestigung am Bügel
- Suitable for all kinds of sauces, mustard, ketchup, mayonnaise
- For mounting on the bracket

#	↗ mm	→ mm	↑ mm	↓ mm
152970	170	170	330	5,0

- Passend für # 152970
- Suitable for # 152970

#		↔ mm
152971	① Aufhangkette mit Haken / Hanging chain with hook	900 x 10 x 10
152972	② Wandaufhänger mit Haken / Wall hanger with hook	155 x 155 x 60
152973	③ Dosierdüse / Dosing nozzle	185 x 60 x 60
152974	④ Deckel schwarz / Lid black	Ø 125 x 20

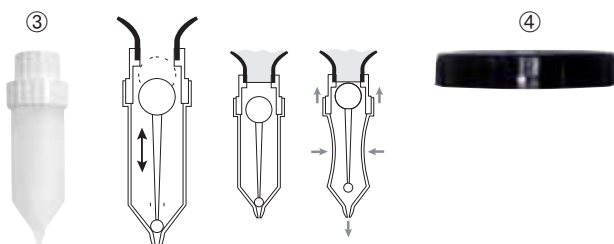

### ZUBEHÖR / ACCESSORIES





# 152410



# 152411

DE	DRUCKKNOPF DOSIERSPENDER MIT GN BEHÄLTER
EN	PUMP DISPENSERS WITH GN CONTAINER
IT	DOSATORI A PRESSIONE CON CONTENITORE GN
ES	DOSIFICADORES CON CONTENEDOR GN

- Material: Edelstahl  
 • GN 1/6 Behälter inklusive  
 • Dosierung einstellbar / ± 30 ml

- Made of stainless steel  
 • GN 1/6 container included  
 • Dosage adjustable / ± 30 ml

#	↔ mm	↑ mm	⌈⌋
152410 ●	180 x 165	320	3,0
152541 ○	180 x 165	320	3,0
152542 ●	180 x 165	320	3,0
152411	180 x 340	340	2 x 3,0
152412	180 x 500	340	3 x 3,0



# 152412

DE	DRUCKKNOPF DOSIERSPENDER MIT GN BEHÄLTER "COOL"
EN	PUMP DISPENSERS WITH GN CONTAINER "COOL"
IT	DOSATORI A PRESSIONE CON CONTENITORE GN "COOL"
ES	DOSIFICADORES CON CONTENEDOR GN "COOL"

- Material: Edelstahl  
 • GN 1/6 Behälter inklusive  
 • Dosierung einstellbar / ± 30 ml  
 • Lieferumfang **ohne** Kühlakkus

- Made of stainless steel  
 • GN 1/6 container included  
 • Dosage adjustable / ± 30 ml  
 • Cooling packs are **not** included



# 152441

#	↔ mm	↑ mm	⌈⌋
152441	185 x 425	375	2 x 3,0
152442	185 x 585	375	3 x 3,0



# 152442

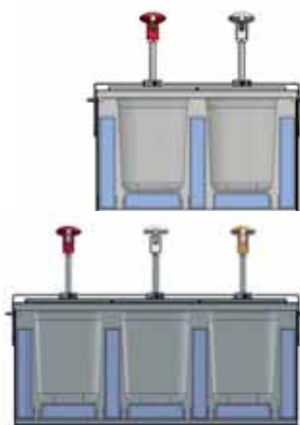

für bis zu 5 Kühlakkus (GN 1/9) / for up to 5 cooling packs (GN 1/9)

für bis zu 7 Kühlakkus (GN 1/9) / for up to 7 cooling packs (GN 1/9)

Passende Kühlakkus

Suitable cooling packs



- 3°C
- 12°C
- 21°C

#	GN	↔ mm	⚖ g
281001	1/9	176 x 108 x 30	500
281006	1/9	176 x 108 x 30	500
281011	1/9	176 x 108 x 30	500

DE	DRUCKKNOPF DOSIERSPENDER
EN	PUMP DISPENSERS
IT	DOSATORI A PRESSIONE
ES	DOSIFICADORES

Material: Edelstahl

- Dosierung einstellbar / ± 30 ml

Made of stainless steel

- Dosage adjustable / ± 30 ml

#	↔ mm	↑ mm	↓ mm
152420 ●	Ø: 120	380	2,2
152543 ○	Ø: 120	380	2,2
152544 ●	Ø: 120	380	2,2
152421	140 x 290	410	2 x 2,2
152422	140 x 440	410	3 x 2,2



# 152420



# 152421



# 152422

DE	DRUCKKNOPF DOSIERSPENDER MIT SICHTFENSTER
EN	PUMP DISPENSERS WITH GLASS WINDOW
IT	DOSATORI A PRESSIONE CON FINESTRELLA
ES	DOSIFICADORES CON VISOR DE CONTENIDO

Material: Edelstahl

- Dosierung einstellbar / ± 30 ml

Made of stainless steel

- Dosage adjustable / ± 30 ml

#	↔ mm	↑ mm	↓ mm
152430 ●	Ø: 100	455	2,0
152545 ○	Ø: 100	455	2,0
152547 ●	Ø: 100	455	2,0
152431	140 x 290	470	2 x 2,0
152432	140 x 440	470	3 x 2,0



# 152431



# 152432

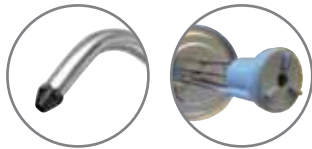

DE	HEBEL DOSIERSPENDER
EN	LEVER DISPENSERS
IT	DOSATORI A LEVA
ES	DOSIFICADORES DE PALANCA

- Material: Edelstahl
- Auslauf schwenkbar
  - Antitropftülle
  - Dosierung einstellbar / ± 35 ml

- Made of stainless steel
- Swivel spout
  - Anti-drip nozzle
  - Dosage adjustable / ± 35 ml



# 152403

#	↔ mm	↑ mm	Ø mm	↓	
152400	–	420	180	4,5	
152401	200 x 400	440	180	2 x 4,5	
152402	200 x 600	440	180	3 x 4,5	
152403	–	380	180	3,0	
152450	–	420	260	10,0	
152453	Ersatzbehälter / Spare container # 152400		180	4,5	
152452	Ersatzbehälter / Spare container # 152450		260	10,0	
152454	geschlossener Deckel / closed lid # 152400		180	4,5	
152455	geschlossener Deckel / closed lid # 152450		260	10,0	



# 152400



# 152401



# 152454 + 152455



# 152450



# 152402

DE	HEBEL DOSIERSPENDER
EN	LEVER DISPENSERS
IT	DOSATORI A LEVA
ES	DOSIFICADORES DE PALANCA

Material: Edelstahl

- Lieferumfang **ohne** GN Behälter
- Geeignet für Behälter mit einer von Tiefe 200 mm
- Auslauf schwenkbar
- Antitropftülle
- Dosierung einstellbar / ± 35 ml

Made of stainless steel

- GN containers are **not** included
- Suitable for containers with a depth of 200 mm
- Swivel spout
- Anti-drip nozzle
- Dosage adjustable / ± 35 ml



# 152416

#	↔ mm	↑ mm	GN	für / for l
152413	330 x 165	380	1/3	7,0
152414	270 x 165	380	1/4	5,0
152416	180 x 165	380	1/6	3,0
152417	330 x 270	380	1/2	10,0

Anwendungsbeispiel /  
Application example



# 152413



# 152414



# 152417

DE	HEBEL DOSIERSPENDER "COOL"
EN	LEVER DISPENSERS "COOL"
IT	DOSATORI A LEVA "COOL"
ES	DOSIFICADORES DE PALANCA "COOL"

Material: Edelstahl

- GN 1/6 Behälter inklusive
- Dosierung einstellbar / ± 35 ml
- Lieferumfang **ohne** Kühlakkus

Made of stainless steel

- GN 1/6 container included
- Dosage adjustable / ± 35 ml
- Cooling packs are **not** included



# 152418

#	↔ mm	↑ mm	l
152418	185 x 425	375	2 x 3,0
152419	185 x 585	375	3 x 3,0

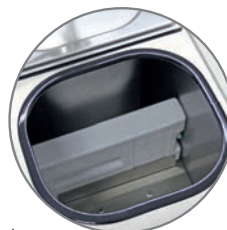
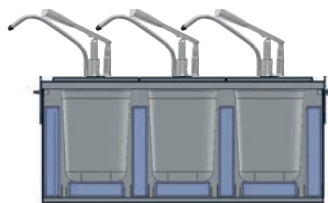
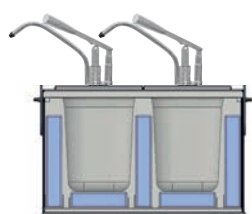

# 152419

Passende Kühlakkus

Suitable cooling packs

#	GN	↔ mm	g
281001	1/9	176 x 108 x 30	500
281006	1/9	176 x 108 x 30	500
281011	1/9	176 x 108 x 30	500



- 3°C
- 12°C
- 21°C





DE	DRUCKKNOPF DOSIERSPENDER
EN	PUMP DISPENSERS
IT	DOSATORI A PRESSIONE
ES	DOSIFICADORES

- Druckknopf-Bedienung
- Schwenkbar
- Spülmaschinengeeignet
- Push-button operation
- Swivelling
- Dishwasher safe

Deckel: Kunststoff (PE)

Lid made of PE

#		↗ mm	→ mm	↑ mm	↓
154710		175	140	150*	2,0
154711		175	140	210*	3,0
154712		175	140	340*	5,0

\* Höheangabe ohne Pumpe / Height without pump

Behälter auch separat erhältlich – siehe Seite 125. / Container also available separately – see page 125.



Deckel: Edelstahl

Lid made of stainless steel

#		↗ mm	→ mm	↑ mm	↓
154720		175	140	150*	2,0
154721		175	140	210*	3,0
154722		175	140	340*	5,0

\* Höheangabe ohne Pumpe / Height without pump



- Druckknopf-Bedienung, schwenkbar
- Spülmaschinengeeignet
- Hub: 30 ml
- Unterbehälter: PS, transparent



- Push-button operation, swivelling
- Dishwasher safe
- Dosage: 30 ml
- Container: PS, transparent

#		↗ mm	→ mm	↑ mm	ml ↓
152922		120	120	130	1000
152923		120	120	175	1500
152924		120	120	265	2200
152932		110	110	130	1000
152933		110	110	175	1450
152934		110	110	265	2000

\* Höheangabe ohne Pumpe / Height without pump

Behälter auch separat erhältlich – siehe Seite 125. / Container also available separately – see page 125.

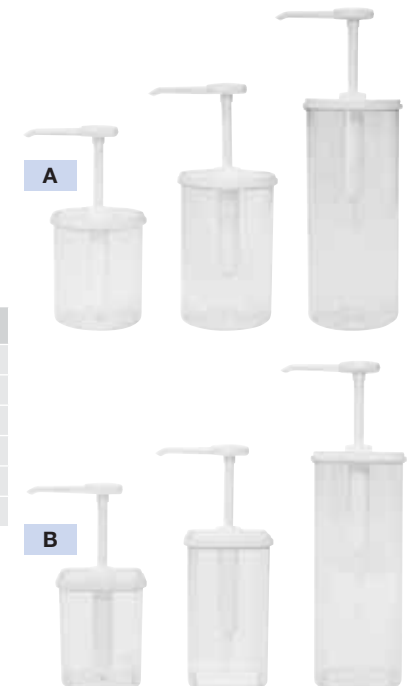

DE	STÄNDER FÜR DRUCKKNOPF-DOSIERSPENDER
EN	STAND FOR PUMP DISPENSERS
IT	SUPPORTO PER DOSATORI A PRESSIONE
ES	SOPORTE PARA DOSIFICADORES

Material: Edelstahl  
(Dosierspender nicht im Lieferumfang enthalten)

Made of stainless steel  
(Dosing dispenser not included)

	#		↗ mm	→ mm	↑ mm
A	152990		400	130	100
B	152991		400	130	100

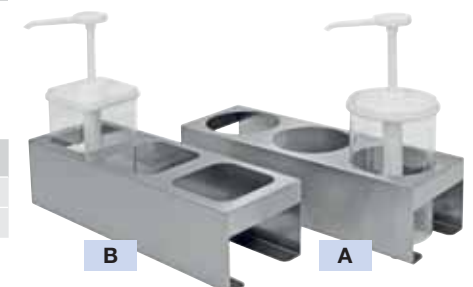



Anwendungsbeispiel /  
Application example



DE	GEBÄCKFÜLLER – GEBOGEN 180°
EN	CREAM DISPENSER – CURVED 180°
IT	DOSATORE PER CREME – CURVO 180°
ES	DOSIFICADOR DE CREMA – CURVADO 180°

- Passend für ca. 3 kg Eimer  
Brotaufstrich (Nuss-Nougat-Creme)
- Material: Edelstahl
  - Hebelbedienung
  - Auslauf schwenkbar
  - Extra dicker Auslauf
  - Separate Dosiertülle inklusive
  - Dosiermenge einstellbar / ± 35 ml

- Suitable for approx. 3 kg bucket of sandwich spread (nut nougat cream)
- Made of stainless steel
  - Lever operation
  - Swivel spout
  - Extra thick spout
  - Separate dosing nozzle included
  - Dosing adjustable / ± 35 ml

#	↑ mm	Ø mm	I ↓
152482	390	255	3,0



DE	WARMHALTEGERÄT – BEHEIZBAR	
EN	WARMING DEVICE – HEATABLE	
IT	DOSATORE A LEVA – RISCALDATO	
ES	DOSIFICADOR – CALEFACTABLE	

- Speziell für warme Saucen
- Material: Edelstahl
  - Hebelbedienung
  - GN 1/6 Behälter – 200 mm
  - Temperatur einstellbar: 30 – 90 °C
  - Anzeige mit Kontrollleuchte
  - Spannung: 230 V, 50 Hz
  - Leistung: 900 W
  - Auslauf schwenkbar
  - Antitropftülle
  - Dosierung einstellbar / ± 35 ml

- Especially for warm sauces
- Made of stainless steel
  - Lever operation
  - GN 1/6 container – 200 mm
  - Temperature adjustable: 30 – 90 °C
  - Display with control light
  - Voltage: 230 V, 50 Hz
  - Power: 900 W
  - Swivel spout
  - Anti-drip nozzle
  - Dosage adjustable / ± 35 ml

**Achtung: Wasserbad-Funktion**

**Attention: Bain-Marie Function**

#	↑ mm	↔ mm	I ↓
152456	510	<b>GN 1/6 – 290 x 230</b>	3,0



DE	HEBELDOSIERSPENDER – BEHEIZBAR	
EN	LEVER DISPENSERS – HEATABLE	
IT	DOSATORE A LEVA – RISCALDATO	
ES	DOSIFICADOR DE PALANCA – CALEFACTABLE	

- Speziell für Kuvertüren, Suppen, Saucen und Dips
- Material: Edelstahl
  - Hebelbedienung
  - Temperatur einstellbar: 0 – 120 °C
  - Anzeige mit Kontrollleuchte
  - Spannung: 230 V, 50 Hz
  - Leistung: 900 W
  - Auslauf schwenkbar
  - Antitropftülle
  - Dosierung einstellbar / ± 35 ml

- Especially for couvertures, soups, sauces and dips
- Made of stainless steel
  - Lever operation
  - Temperature adjustable: 0 – 120 °C
  - Display with control light
  - Voltage: 230 V, 50 Hz
  - Power: 900 W
  - Swivel spout
  - Anti-drip nozzle
  - Dosage adjustable / ± 35 ml

**Achtung: Wasserbad-Funktion**

**Attention: Bain-Marie Function**

#	↑ mm	Ø mm	I ↓
152470	510	180	3,0

DE	GEBÄCKFÜLLER
EN	CREAM DISPENSERS
IT	DOSATORI PER CREME
ES	DOSIFICADORES DE CREMA

Speziell für Krapfen, Croissants und andere Gebäckarten

- Material: Edelstahl
- Hebelbedienung
- Dosierung einstellbar / ± 35 ml

Especially for doughnuts, croissants and other pastries

- Made of stainless steel
- Lever operation
- Dosage adjustable / ± 35 ml

#	↑ mm	Ø mm	↓	
152480	460	180	4,5	
152481	470	180	4,5	
152493	460	260	10,0	



# 152481

# 152493

DE	GEBÄCKFÜLLER – BEHEIZBAR	
EN	CREAM DISPENSER – HEATABLE	
IT	DOSATORE PER CREME – RISCALDATO	
ES	DOSIFICADOR DE CREMA – CALEFACTABLE	

Speziell für Kuvertüren, Schokolade, Nougatcreme, Vanillecreme

- Material: Edelstahl
- Hebelbedienung
- Temperatur einstellbar: 0 – 120 °C
- Anzeige mit Kontrollleuchte
- Spannung: 230 V, 50 Hz
- Leistung: 900 W
- Dosierung einstellbar / ± 35 ml

**Achtung: Wasserbad-Funktion**

Especially for couvertures, chocolate, nougat cream, vanilla cream

- Made of stainless steel
- Lever operation
- Temperature adjustable: 0 – 120 °C
- Display with control light
- Voltage: 230 V, 50 Hz
- Power: 900 W
- Dosage adjustable / ± 35 ml

**Attention: Bain-Marie Function**

#	↑ mm	Ø mm	↓	
152460	510	180	3,0	



DE	HILFSWERKZEUG FÜR HEBEL DOSIERSPENDER
EN	WRENCH FOR LEVER DISPENSERS
IT	CHIAVE PER DOSATORI A LEVA
ES	LLAVE PARA DOSIFICADORES CON PALANCA

• Für optimales Öffnen und Verschließen des Kolbens aller Hebeldosierspender

• For optimal opening and closing of the piston of all lever dispensers

#	für/for #
152305	152400, 152401, 152402, 152403, 152450, 152413, 152414, 152416, 152417, 152418, 152419, 152490, 152492, 152482, 152456, 152470, 152480, 152481, 152493, 152460





### Größenangaben und Kombinationsbeispiele / Sizes and combination examples

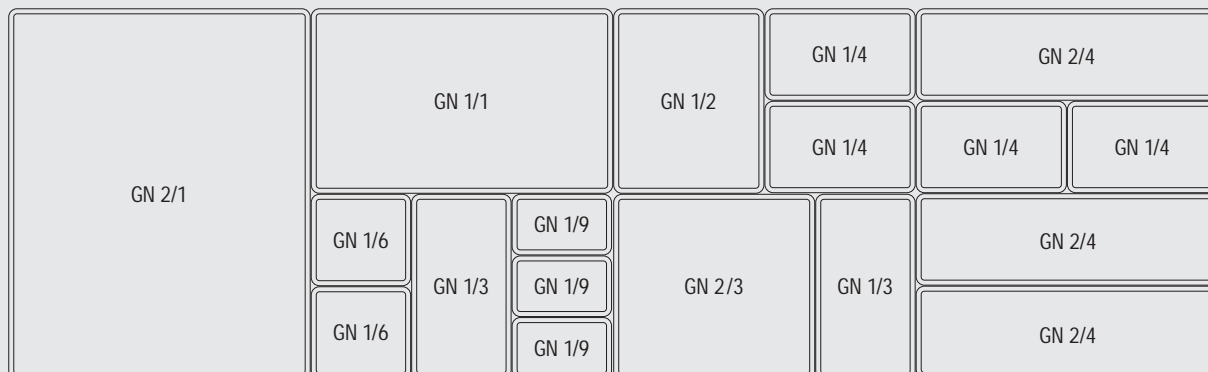

GN 1/1	GN 1/2	GN 1/3	GN 1/4	GN 1/6	GN 1/9	GN 2/1	GN 2/3	GN 2/4
530 x 325 mm	325 x 265 mm	325 x 176 mm	265 x 162 mm	176 x 162 mm	176 x 108 mm	650 x 530 mm	354 x 325 mm	530 x 162 mm

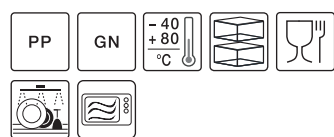

DE	BEHÄLTER GN AUS POLYPROPYLEN
EN	CONTAINER GN MADE OF POLYPROPYLENE
IT	CONTENITORE GN IN POLIPROPILENE
ES	CONTENEDOR GN EN POLIPROPILENO

- Integrierte Literskala
- Robust, formstabil, stapelbar
- Ideal zum Lagern und Aufbewahren aller Lebensmittel
- Integrated liter scale
- Robust, dimensionally stable, stackable
- Ideal for storing and preserving all foodstuffs

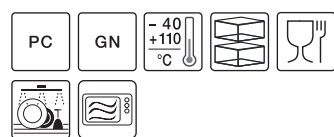

DE	BEHÄLTER GN AUS POLYCARBONAT
EN	CONTAINER GN MADE OF POLYCARBONATE
IT	CONTENITORE GN IN POLICARBONATO
ES	CONTENEDOR GN EN POLICARBONATO

- Integrierte Literskala
- Robust, formstabil, stapelbar
- Ideal zum Lagern und Aufbewahren aller Lebensmittel
- Integrated liter scale
- Robust, dimensionally stable, stackable
- Ideal for storing and preserving all foodstuffs

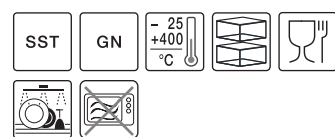

DE	BEHÄLTER GN AUS EDELSTAHL
EN	CONTAINER GN MADE OF STAINLESS STEEL
IT	CONTENITORE GN IN ACCIAIO INOX
ES	CONTENEDOR GN EN ACERO INOX

- Elektrolytisch polierte Oberfläche
- Robust, formstabil, stapelbar
- Ideal zum Lagern und Aufbewahren aller Lebensmittel
- Electrolytic polished surface
- Robust, dimensionally stable, stackable
- Ideal for storing and preserving all foodstuffs

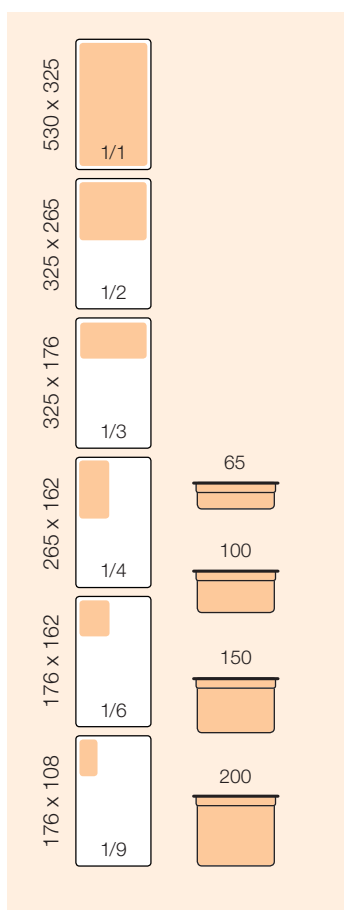

DE	BEHÄLTER GN	PP	GN	-40 +80 °C				
EN	CONTAINER GN							
IT	CONTENITORE GN							
ES	CONTENEDOR GN							

#	GN	↑ mm	↓ mm	↓ mm	
530000	1/1	65	9,0	2,5	
530001	1/1	100	13,3	2,6	
530002	1/1	150	20,0	2,8	
530003	1/1	200	26,4	2,9	
530010	1/2	65	4,0	2,5	
530011	1/2	100	6,1	2,5	
530012	1/2	150	9,0	2,5	
530013	1/2	200	11,9	2,5	
530020	1/3	65	2,5	2,5	
530021	1/3	100	3,8	2,5	
530022	1/3	150	5,5	2,6	
530023	1/3	200	7,1	2,6	
530030	1/4	65	1,7	2,3	
530031	1/4	100	2,6	2,3	
530032	1/4	150	3,8	2,5	
530033	1/4	200	4,8	2,6	
530040	1/6	65	1,0	2,3	
530041	1/6	100	1,6	2,4	
530042	1/6	150	2,3	2,5	
530043	1/6	200	2,8	2,6	
530050	1/9	65	0,6	1,9	
530051	1/9	100	0,9	1,9	

DE	ABTROPFGITTER GN						
EN	DRAINER GRID GN	PP	GN	-40 +80 °C			
IT	FONDO PERFORATO GN						
ES	PLACA ESCURRIDORA GN						

- Geeignet für Behälter aus PP und PC
- Suitable for PP and PC containers

#	GN	↑ mm	↓ mm
530060	1/1	20	2,7
530061	1/2	20	2,7
530062	1/3	20	2,5
530063	1/4	20	2,0
530064	1/6	20	2,5



# 530060

DE	DECKEL GN						
EN	LID GN	PP	GN	-40 +80 °C			
IT	COPERCHIO GN						
ES	TAPA GN						

- Ausführung: luftdichte Silikondichtung
- Einfaches Handling durch Entlüftungsventil
- Type: airtight silicone seal
- Easy handling due to valve

#	GN	↑ mm	↓ mm
530070	1/1	13	2,4
530071	1/2	12	2,4
530072	1/3	12	2,3
530073	1/4	12	2,3
530074	1/6	12	2,2



# 530071

**i** Deckel ist nicht mit HACCP Clips anwendbar / Lid can't be used with HACCP clips

DE	DECKEL GN						
EN	LID GN	PP	GN	HACCP	-40 +80 °C		
IT	COPERCHIO GN						
ES	TAPA GN						

- Ausführung: einrastend
- HACCP Clips verwendbar
- Lieferumfang ohne HACCP Clips
- Type: latching
- HACCP clips usable
- Delivery without HACCP clips

#	GN	↑ mm	↓ mm
530005	1/1	13	2,4
530015	1/2	13	1,7
530025	1/3	13	1,6
530035	1/4	13	1,6
530045	1/6	13	1,4
530055	1/9	13	1,5

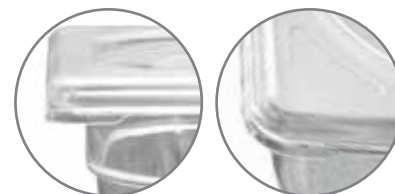

# 530035

DE	HACCP MARKIERUNGS CLIP						
EN	HACCP MARKING CLIP	PP	GN	HACCP	-40 +80 °C		
IT	HACCP CLIP DI MARCATURA						
ES	HACCP CLIP DE MARCADO						

- Set à 12 Stück je Farbe
- Passend für Deckelausführung einrastend
- Set of 12 pieces per color
- Suitable for lids type latching

#	
530195	●
530196	●
530197	●
530198	●
530199	●



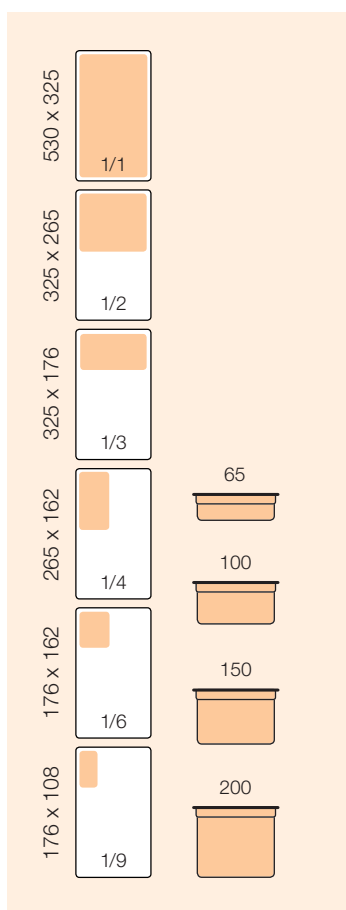

DE	BEHÄLTER GN	
EN	CONTAINER GN	
IT	CONTENITORE GN	
ES	CONTENEDOR GN	

#	GN	↑ mm	↓ mm	↓ mm
530100	1/1	65	9,0	2,6
530101	1/1	100	13,3	2,7
530102	1/1	150	20,0	2,9
530103	1/1	200	26,4	3,0
530110	1/2	65	4,0	2,6
530111	1/2	100	6,1	2,6
530112	1/2	150	9,0	2,6
530113	1/2	200	11,9	2,6
530120	1/3	65	2,5	2,6
530121	1/3	100	3,8	2,6
530122	1/3	150	5,5	2,6
530123	1/3	200	7,1	2,7
530130	1/4	65	1,7	2,3
530131	1/4	100	2,6	2,3
530132	1/4	150	3,8	2,5
530133	1/4	200	4,8	2,6
530140	1/6	65	1,0	2,3
530141	1/6	100	1,6	2,5
530142	1/6	150	2,3	2,5
530143	1/6	200	2,8	2,6
530150	1/9	65	0,6	2,0
530151	1/9	100	0,9	2,0

DE	DECKEL GN						
GB	LID GN	PC	GN	-40 +110 °C			
IT	COPERCHIO GN						
ES	TAPA GN						

- Ausführung: aufliegend
- Mit Griff
- Type: overlying
- With handle

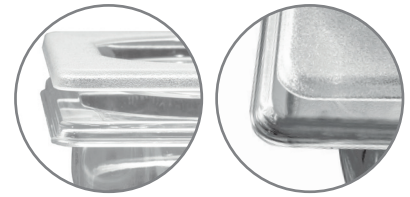

#	GN	↑ mm	↓ mm
530105	1/1	11	2,5
530115	1/2	11	2,5
530125	1/3	11	2,4
530135	1/4	11	2,4
530145	1/6	11	2,3
530155	1/9	11	1,9



# 530135

Deckel ist nicht mit HACCP Clips anwendbar / Lid can't be used with HACCP clips

DE	HACCP MARKIERUNGS CLIP						
EN	HACCP MARKING CLIP	PP	GN	HACCP	-40 +80 °C		
IT	HACCP CLIP DI MARCATURA						
ES	HACCP CLIP DE MARCADO						

- Set à 12 Stück je Farbe
- Passend für Deckelausführung einrastend
- Set of 12 pieces per color
- Suitable for lids type latching



#	
530195	
530196	
530197	
530198	
530199	



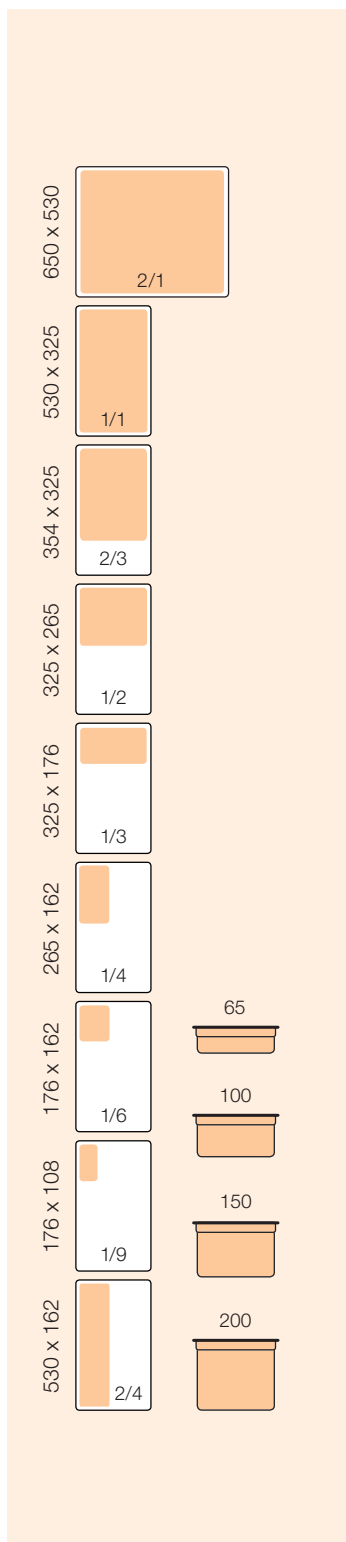

DE	BEHÄLTER GN	
EN	CONTAINER GN	
IT	CONTENITORE GN	
ES	CONTENEDOR GN	

#	GN	↑ mm	↓ mm	↓ mm
530270	2/1	20	4,5	0,8
530271	2/1	40	12,0	0,8
530272	2/1	65	19,0	0,8
530200	1/1	20	1,9	0,8
530201	1/1	40	5,4	0,8
530202	1/1	65	8,7	0,8
530203	1/1	100	13,0	0,8
530204	1/1	150	20,0	0,8
530205	1/1	200	26,0	0,8
530210	2/3	20	1,3	0,8
530211	2/3	40	3,4	0,8
530212	2/3	65	5,5	1,0
530213	2/3	100	8,4	0,8
530214	2/3	150	12,0	0,8
530215	2/3	200	16,0	1,0
530220	1/2	20	0,8	0,8
530221	1/2	40	2,4	0,8
530222	1/2	65	3,8	0,8
530223	1/2	100	5,9	0,8
530224	1/2	150	8,7	0,8
530225	1/2	200	11,0	1,0
530230	1/3	20	0,6	0,8
530231	1/3	40	1,5	0,8
530232	1/3	65	2,5	0,8
530233	1/3	100	3,8	0,8
530234	1/3	150	5,5	0,8
530235	1/3	200	7,0	0,9
530240	1/4	20	0,4	0,8
530241	1/4	40	1,2	0,8
530242	1/4	65	1,7	0,8
530243	1/4	100	2,7	0,8
530244	1/4	150	3,8	0,8
530245	1/4	200	4,8	1,0
530250	1/6	65	1,0	0,8
530251	1/6	100	1,6	0,8
530252	1/6	150	2,2	0,8
530253	1/6	200	2,8	1,0
530260	1/9	65	0,6	0,8
530261	1/9	100	0,9	0,8
530282	2/4	65	4,3	0,7
530283	2/4	100	6,5	0,7
530284	2/4	150	10,0	0,7

DE	BEHÄLTER GN								
EN	CONTAINER GN	SST	GN	-25 +400 °C					
IT	CONTENITORE GN								
ES	CONTENEDOR GN								

- Mit Boden- und Seitenlochung
- With perforated base and sides

#	GN	↑ mm	↓ mm	↓ mm
530300	1/1	65*	8,7	0,8
530301	1/1	100	13,0	0,8
530302	1/1	150	20,0	0,8
530310	2/3	65*	5,5	1,0
530311	2/3	100	8,4	0,8
530312	2/3	150	12,0	0,8
530320	1/2	65*	3,8	0,8
530321	1/2	100	5,9	0,8
530322	1/2	150	8,7	0,8

\* 65 mm: nur mit Bodenlochung / only with perforated base



# 530300



# 530311

DE	DECKEL GN								
EN	LID GN	SST	GN	-25 +400 °C					
IT	COPERCHIO GN								
ES	TAPA GN								

- Mit Griff
- With handle

#	GN	↑ mm	↓ mm
530206	1/1	30	0,7
530216	2/3	30	0,7
530226	1/2	30	0,7
530236	1/3	30	0,7
530246	1/4	30	0,7
530256	1/6	30	0,7
530266	1/9	30	0,7
530286	2/4	30	0,7



# 530226

DE	DECKEL GN								
EN	LID GN	SST	GN	-25 +400 °C					
IT	COPERCHIO GN								
ES	TAPA GN								

- Mit Griff
- With handle
- Mit Löffelaussparung
- With spoon recess

#	GN	↑ mm	↓ mm
530207	1/1	30	0,7
530217	2/3	30	0,7
530227	1/2	30	0,7
530237	1/3	30	0,7
530247	1/4	30	0,7
530257	1/6	30	0,7
530267	1/9	30	0,7



# 530227

DE	STEG								
EN	ADAPTOR BAR	SST	GN	-25 +400 °C					
IT	SEPARATORE								
ES	BARRA ADAPTADORA								

- Geeignet für Behälter GN
- Suitable for containers GN

#	GN	↑ mm	↓ mm
530490	1/1	32	0,8
530491	1/2	32	0,8



DE	STABMIXER
EN	STICK BLENDER
IT	MIXER AD IMMERSIONE
ES	BATIDORA DE INMERSIÓN



Digital-anzeige

Digital Display

- Professionelle Qualität
- Gehäuse aus stabilem Kunststoff
- Rührstab und Messer aus Edelstahl
- Leicht zu reinigen
- Luftgekühlter Motor
- Für die Zubereitung von Eis, Suppen, Mousses, Soßen, Füllungen, Mayonnaise, etc.

- Professional quality
- Housing made of sturdy plastic
- Stainless steel blender and blades
- Easy to clean
- Air-cooled motor
- For the preparation of ice cream, soups, purées, sauces, fillings, mayonnaise, etc.



# 153600: nur Motorblock / only motor

340 mm

# 153601: Stab / blender



270 mm

# 153610

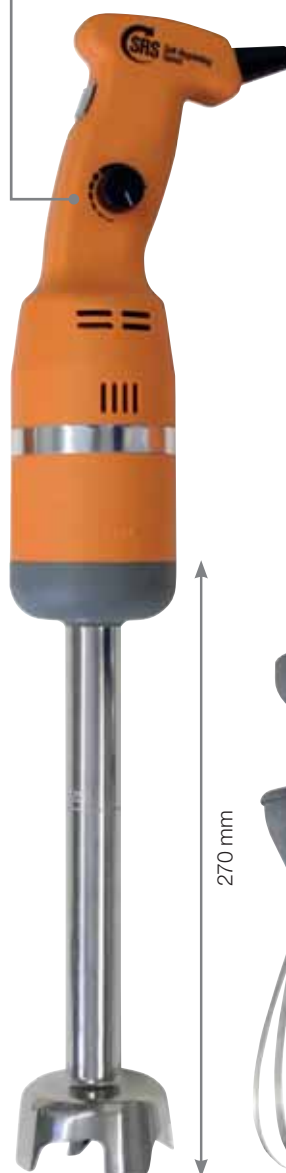
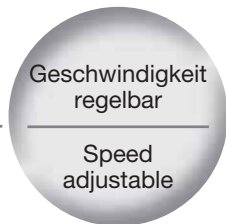





270 mm

# 153620



290 mm

#	153610	153620	153600
	mit Rührstab / with blender	mit Rührstab und Schneebesen / with blender and whisk	<u>nur</u> Motorblock / <u>only</u> motor
	250 W	250 W	400 W
	230 V 50–60 Hz	230 V 50–60 Hz	230 V 50–60 Hz
Geschwindigkeit regelbar Speed adjustable	nein / no	ja / yes	ja / yes
Umdrehungen / Revolutions min.	15.000	2.500 – 15.000	2.000 – 15.000
Ø mm	75	75	100
↗ mm 	285	285	350
↗ mm 	270	270	–
 kg	1,0	1,0	2,1



Zubehör für MIX 400 V # 153600	153601	153602	153603	153604
	Rührstab / blender	Rührstab / blender	Rührstab / blender	Schneebesen / whisk
Ø mm	85	85	85	120
↗ mm	340	440	540	330
 kg	0,9	1,0	1,2	0,8



DE	LIKÖR- UND FONDANTTRICHTER
EN	CONFECTIONERY FUNNEL
IT	IMBUTO COLATORE
ES	EMBUDO COLADOR

- |                                       |  |
|---------------------------------------|--|
| Material: Edelstahl                   | Made of stainless steel,                       |
| • Ergonomischer Griff aus Kunststoff  | • Ergonomic handle made of plastic             |
| • Mit 3 Dosiertüllen (3, 4 und 5 mm)  | • With three different nozzles (3, 4 und 5 mm) |
| • Inklusive Ständer und Auffangschale | • Including wire rack and dripping dish        |

#	Ø mm	↑ mm	I	↓
199940	195	210	1,8	



- |                                      |  |
|--------------------------------------|--|
| Material: Edelstahl                  | Made of stainless steel,                       |
| • Mit 3 Dosiertüllen (2, 4 und 6 mm) | • With three different nozzles (2, 4 and 6 mm) |
| • Inklusive Ständer                  | • Including wire rack                          |

#	Ø mm	↑ mm	I	↓
199999	190	230	1,5	



DE	TRÜFFELFÜLLER
EN	TRUFFLE FILLER
IT	IMBUTO COLATORE
ES	EMBUDO COLADOR

- |  |   |
|--|---|
| Material: Edelstahl, lebensmittelechter Kunststoff                           | Made of stainless steel, food-safe plastic                                      |
| • Universell zum Füllen mit Quark, Pudding, Ganache, Likör, Marmelade, Creme | • Universal for filling with curd cheese, pudding, ganache, liqueur, jam, cream |
| • Stufenlose und genaue Mengeneinstellung 1 – 17 g                           | • Stepless and precise quantity adjustment 1 – 17 g                             |
| • Gewicht: 0,7 kg  | • Weight: 0.7 kg  |

#	Ø mm	↑ mm	I	↓
199950	300	200	1,0	



DE	BACKTRENNSPRAY	
EN	RELEASE SPRAY	
IT	SPRAY STACCANTE ANTIADERENTE	
ES	DESMOLDEANTE EN SPRAY	

- |  |   |
|--|---|
| Das perfekte Trennspray für Bäckereien, Konditoreien, Küchen und Gastronomie. Speziell für WALTER-Backformen geeignet. Kein Anbacken oder Ankleben der Backwaren; keine Rückstände in der Form oder auf dem Blech. Reines Lebensmittel, 100 % geschmacksneutral. Zutaten: Pflanzliche Öle<br>Verdickungsmittel: Carnaubawachs<br>Emulgator: Sonnenblumenlecithine<br>Treibgas: Butan / Isobutan / Propan<br><b>Nur zur gewerblichen Verarbeitung. Nicht für Luftfracht zugelassen.</b> | The ideal release spray for bakeries, confectioneries, hotel and restaurant kitchens. Especially suitable for WALTER baking moulds. No caking or sticking of the baked goods; no residues in the mould or on the tray. 100 % safe for consumption and tasteless.<br>Ingredients: vegetable oils<br>Thickener: carnauba wax<br>Emulsifier: sunflower lecithin<br>Propellant: butane / isobutane / propane<br><b>Only for professional use. Not permitted for transport via airfreight.</b> |
|--|---|

#	ml	↑	↓
266960	500	Butan / Isobutan / Propan	

DE	FONDANTTRICHTER / SAUCENPORTIONIERER – ELEKTRISCH BEHEIZBAR
EN	SAUCE-WARMER
IT	SCALDA SALSE
ES	CALENTADOR DE SALSAS



Material: Edelstahl

- Zum Warmhalten und Dosieren von flüssigen Speisen wie Soßen, Cremes, Schokolade, Füllungen, etc.
- Temperatur von +40° C bis +70° C einstellbar
- Inklusive herausnehmbarer Auffangschale
- Kein Wasserbad – Temperatureaustausch erfolgt über Direktkontakt / Luft
- Trichter: Volumen 2 Liter
- Inklusive Deckel und 3 Dosiertüllen

Made of stainless steel

- For keeping warm and dosing liquid foods such as sauces, creams, chocolate, fillings, etc.
- Temperature adjustable from +40° C to +70° C
- Including removable drip tray
- No bain marie – temperature exchange via direct contact / air
- Funnel: Volume 2 litres
- Including lid and 3 dosing nozzles



#	150590
→ mm	350
↗ mm	285
↑ mm	370
	300 W
	220 – 240 V / 50/60 Hz
	4,8 kg



DE	PLANETEN-RÜHRMASCHINE „CHEF 9000“
EN	PLANETARY MIXER „CHEF 9000“
IT	IMPASTATRICE PLANETARIA „CHEF 9000“
ES	BATIDORA PLANETARIA „CHEF 9000“

- Volumen: 7,0 Liter
- Leistung: 325 W
- Spannung: 230 V / 50 – 60 Hz
- Umdrehungen pro Minute: 40 Minimum / 250 Maximum
- Rührgeschwindigkeit stufenlos regelbar
- Inklusive Schneebesen, Knethaken und Flachrührer
- Gehäuse aus lackiertem Stahl
- Rührschüssel aus rostfreiem Edelstahl
- Schüssel Ø: 250 mm / Höhe: 220 mm
- Sicherheitsschutzgitter mit Mikroschalter
- Speziell für leichte Massen wie Waffelteig, Sahne etc.

- Volume: 7,0 liters
- Power: 325 W
- Voltage: 230 V / 50 – 60 Hz
- Revolutions per minute: 40 minimum / 250 maximum
- Speed adjustable
- Including whisk, hook and spatula
- Housing made of varnished steel
- Mixing bowl made of stainless steel
- Bowl Ø: 250 mm / Height: 220 mm
- Safety guard with micro switch
- Especially for light masses like waffle dough, cream etc.



#	↔ mm		kg
159900	420 x 250 x 420 mm	17,5	
159902	Ersatzschüssel <b>mit</b> Griff / Spare bowl <b>with</b> handle		

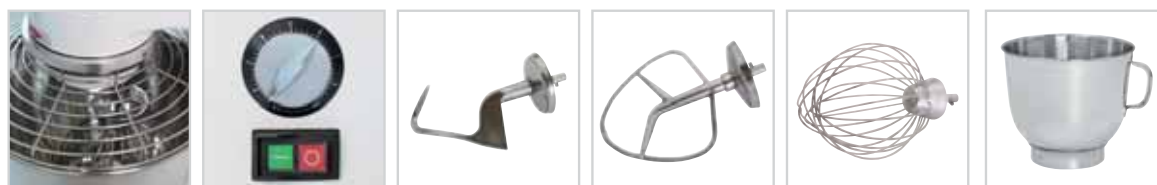



DE	LEBENSMITTEL-SPRÜHPISTOLE "ALEXO 200+"	
EN	SPRAY GUN "ALEXO 200+"	
IT	PISTOLA POLVERIZZATRICE ELETTRICA "ALEXO 200+"	
ES	PISTOLA PULVERIZADORA ELÉCTRICA "ALEXO 200+"	

- Verarbeitbare Materialien: Butter, Öle, Fette, Wachse, Gelee, Konfitüre, Trennmittel und Emulsionen
- **100% lebensmittelecht**
- Für warme Flüssigkeiten bis 65 °C
- Fördermenge: bis zu 220 g/min
- Viskosität: max. 80 DIN/sek
- Inhalt: 700 ml
- Leistung: 60 Watt
- Gewicht: 1,8kg
- Wird mit Rundstrahldüse R6 geliefert
- Usability: butter, oil, fat, wax, jelly, jam, releasing agent and emulsion
- **100% food safe**
- Usable for warm liquids max. 65 °C
- Dispense quantity: up to 220 g/min
- Viscosity rate: max. 80 DIN/sec
- Volume: 700 ml
- Power: 60 W
- Weight: 1.8 kg
- Supplied with circular jet nozzle R6

#		
153900	Sprühpistole/spray gun	

DE	ZUBEHÖR FÜR SPRÜHPISTOLE "ALEXO 200"
EN	ACCESSORIES FOR SPRAY GUN "ALEXO 200"
IT	PEZZI DI RICAMBIO PER PISTOLA POLVERIZZATRICE ELETTRICA "ALEXO 200"
ES	RECAMBIOS PARA PISTOLA PULVERIZADORA ELÉCTRICA "ALEXO 200"



#		
153901	Flüssigkeitsaustritt 0,4 mm / feinsten Wasserstaub Rundstrahldüse R4 / circular jet nozzle R4	



153902	Flüssigkeitsaustritt 0,6 mm Rundstrahldüse R6 / circular jet nozzle R6	
--------	---	--



153903	Flüssigkeitsaustritt 0,8 mm / für dickflüssigere Flüssigkeiten Rundstrahldüse R8 / circular jet nozzle R8	
--------	--	--



153904	zum Reinigen von Backöfen / Combi-Dämpfer Flachstrahldüse F7S / flat jet nozzle F7S	
--------	--	--



153905	Reinigungsdüse / cleaning nozzle	
--------	----------------------------------	--



153906	Düsenverlängerung / nozzle extension	
--------	--------------------------------------	--



153908	Behälter mit Deckel / container with lid	
153935	Ersatzdeckel / replacement lid	
153909	Drall mit Ventilsfeder / spin with spring	

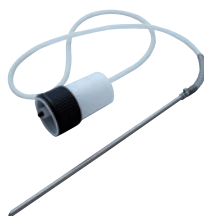

DE	ANSAUGVORRICHTUNG FÜR "ALEXO 200"
EN	SUCTION PIPE FOR "ALEXO 200"
IT	DISPOSITIVO DI ASPIRAZIONE PER "ALEXO 200"
ES	DISPOSITIVO DE ASPIRACIÓN PARA "ALEXO 200"

#		
153961	150 cm Schlauchlänge, 40 cm Rohrlänge (Edelstahl) / hose 150 cm length, stainless steel pipe 40 cm	

DE	DRUCKPUMPZERSTÄUBER			
EN	COMPRESSED AIR SPRAYER	PP	HDPE	
IT	POLVERIZZATORE CON POMPA A PRESSIONE			
ES	PULVERIZADOR DE BOMBA DE PRESIÓN			

- |   |  |
|---|--|
| <ul style="list-style-type: none"> <li>• Mit Dauersprühfunktion</li> <li>• ErgoGrip, extra langer Komfortgriff</li> <li>• Integrierte Skala</li> <li>• Transparente Füllstandsanzeige</li> <li>• Sprühwinkel bei feiner Zerstäubung: 60°</li> <li>• Sprühhänge bei Vollstrahl: 4 Meter</li> <li>• Förderleistung: 300 ml/min</li> <li>• Maximaler Betriebsdruck: 4 bar</li> <li>• Maximale Betriebstemperatur: -5 bis +30 °C</li> </ul> | <ul style="list-style-type: none"> <li>• With permanent spray function</li> <li>• ErgoGrip, extra long comfort handle</li> <li>• Integrated scale</li> <li>• Transparent fill level indicator</li> <li>• Spray angle with fine atomization: 60°</li> <li>• Spray length with full jet: 4 meters</li> <li>• Pumping capacity: 300 ml/min</li> <li>• Maximum operating pressure: 4 bar</li> <li>• Maximum operating temperature: -5 to +30 °C</li> </ul> |
|---|--|

#	↗ mm	→ mm	↑ mm	↓ mm	
153950	233	135	313	1,8	

Nur in Anwendung mit wasserbasierenden Flüssigkeiten! / Only for use with water-based liquids!



DE	DRUCKPUMPZERSTÄUBER			
EN	COMPRESSED AIR SPRAYER	PP	HDPE	
IT	POLVERIZZATORE CON POMPA A PRESSIONE			
ES	PULVERIZADOR DE BOMBA DE PRESIÓN			

- |  |  |
|--|--|
| <ul style="list-style-type: none"> <li>• ErgoGrip, extra langer Komfortgriff</li> <li>• Standring mit SoftTouch-Boden</li> <li>• Integrierte Skala</li> <li>• Transparente Füllstandsanzeige</li> <li>• Sprühwinkel bei feiner Zerstäubung: 60°</li> <li>• Sprühhänge bei Vollstrahl: 4 Meter</li> <li>• Förderleistung: 300 ml/min</li> <li>• Maximaler Betriebsdruck: 3 bar</li> <li>• Maximale Betriebstemperatur: -5 bis +30 °C</li> </ul> | <ul style="list-style-type: none"> <li>• ErgoGrip, extra long comfort handle</li> <li>• Stand ring with SoftTouch base</li> <li>• Integrated scale</li> <li>• Transparent fill level indicator</li> <li>• Spray angle with fine atomization: 60°</li> <li>• Spray length with full jet: 4 meters</li> <li>• Delivery rate: 300 ml/min</li> <li>• Maximum operating pressure: 3 bar</li> <li>• Maximum operating temperature: -5 to +30 °C</li> </ul> |
|--|--|

#	↗ mm	→ mm	↑ mm	↓ mm	
153952	206	119	313	1,2	





DE	BACKBLECHE / KONVEKTOMATENBLECHE	
EN	BAKING TRAYS	
IT	TEGLIE	
ES	BANDEJAS PARA HORNO	

Material: Stahlblech, Granit-Emaile

Made of steel, enamel granite

- Beidseitig beschichtet
- Materialstärke: 1,0 mm

- Coated on both sides
- Thickness: 1.0 mm

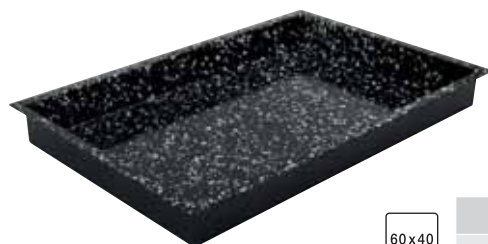

**600 x 400 – Ausführung: 4 Seiten 90°**

**600 x 400 – Type: 4 sides 90°**

#	↗ mm	→ mm	↑ mm	
382562	600	400	60	



**GN 2/1 – Ausführung: 4 Seiten 90°**

**GN 2/1 – Type: 4 sides 90°**

#	↗ mm	→ mm	↑ mm	
382500	530	650	20	
382501	530	650	40	
382502	530	650	60	

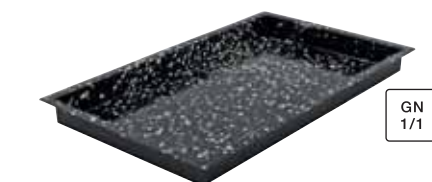

**GN 1/1 – Ausführung: 4 Seiten 90°**

**GN 1/1 – Type: 4 sides 90°**

#	↗ mm	→ mm	↑ mm	
382510	530	325	20	
382511	530	325	40	
382512	530	325	60	

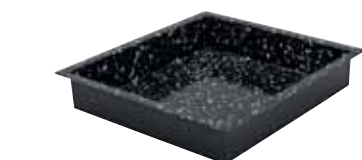

**GN 2/3 – Ausführung: 4 Seiten 90°**

**GN 2/3 – Type: 4 sides 90°**

#	↗ mm	→ mm	↑ mm	
382520	354	325	20	
382521	354	325	40	
382522	354	325	60	

DE	GN-BACKBLECHE / KONVEKTOMATENBLECHE
EN	GN-BAKING TRAYS
IT	TEGLIE GN
ES	BANDEJAS PARA HORNO GN



Material: Stahlblech, Emaille, schwarz  
 • Beidseitig beschichtet

Made of steel, enamel, black  
 • Coated on both sides

#	↗ mm	→ mm	↑ mm	⏊ mm	l
382530	530	325	20	0,8	2,5
382531	530	325	40	0,8	5,3
382532	530	325	65	0,8	8,8
382533	325	265	40	0,8	2,5
382534	325	265	65	0,8	4,0
382535	325	176	40	0,8	1,8
382536	325	176	65	0,8	2,4



GN 1/1  
GN 1/2  
GN 1/3

DE	BACKTRENNPAPIERE	<b>GN</b>
EN	BAKING RELEASE PAPERS	
IT	CARTA DA FORNO	
ES	PAPEL DE HORNO SILICONADO	

Pergamentersatz, gebleicht  
 • Beidseitig silikonisiert  
 • Mehrmals verwendbar

Greaseproof, bleached  
 • Two sides siliconized  
 • Multiple bakes

**“SUPER EXTRA”**

**“SUPER EXTRA”**

#	↔ mm x m	⚖ g/m <sup>2</sup>	
103032	320 x 530 <b>GN 1/1</b>	41	500
103078	520 x 640 <b>GN 2/1</b>	41	500



**“SUPER CLASSIC”**

**“SUPER CLASSIC”**

104032	320 x 530 <b>GN 1/1</b>	39	500
--------	-------------------------	----	-----

**NEW**

Passende GN-Backbleche auf Seite 41. / Suitable GN-baking trays on page 41.

DE	GRILLROSTE	<b>SST</b>
EN	GRIDS	
IT	GRIGLIE	
ES	REJILLAS	

#		↗ mm	→ mm		∅ mm	Drähte ∅ mm / wire ∅ mm
156110		600	400	2	6	24 / 3
156111	<b>GN 1/1</b>	530	325	1	7	20 / 3
156112	<b>GN 2/3</b>	354	325	1	5	15 / 2
156113	<b>GN 2/1</b>	650	530	3	6	32 / 2

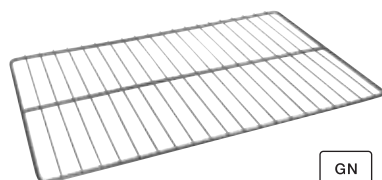
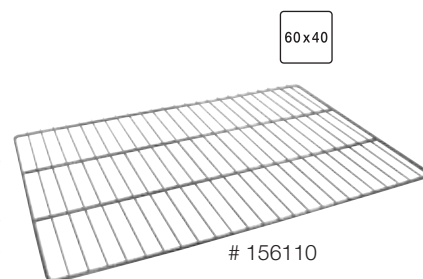

# 156111

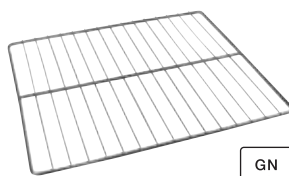



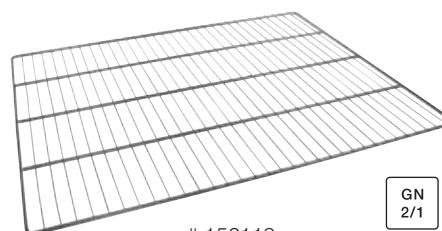





# 156112



# 156113



 <p><b>GEWERBEQUALITÄT</b></p> <ul style="list-style-type: none"> <li>• Edelstahlgehäuse</li> <li>• Hochwertige Glaskeramik</li> </ul> <p><b>COMMERCIAL QUALITY</b></p> <ul style="list-style-type: none"> <li>• Stainless steel case</li> <li>• High quality glass ceramic</li> </ul>	 <p><b>GLASKERAMIK</b></p> <ul style="list-style-type: none"> <li>• Kein Einbrennen</li> <li>• Einfache Reinigung mit einem feuchten Stofftuch</li> </ul> <p><b>GLASS CERAMIC</b></p> <ul style="list-style-type: none"> <li>• No burning in</li> <li>• Easy cleaning with a damp cloth</li> </ul>	 <p><b>FUNKTIONEN</b></p> <ul style="list-style-type: none"> <li>• Timerfunktion bis 99 Minuten</li> </ul> <p><b>FEATURES</b></p> <ul style="list-style-type: none"> <li>• Timer function up to 99 minutes</li> </ul>	 <p><b>SICHERHEIT</b></p> <ul style="list-style-type: none"> <li>• Alle Geräte haben eine automatische Pfannen- und Topferkennung</li> <li>• Nur ferromagnetische Pfannen und Töpfe können erhitzt werden</li> </ul> <p><b>SAFETY</b></p> <ul style="list-style-type: none"> <li>• All devices have an automatic pan and pot detection</li> <li>• Only ferromagnetic pans and pots can be heated</li> </ul>
 <p><b>EINFACHE BEDIENUNG</b></p> <ul style="list-style-type: none"> <li>• Einfache und schnelle Einstellung auf der Glasoberfläche oder dem Display</li> </ul> <p><b>EASY HANDLING</b></p> <ul style="list-style-type: none"> <li>• Easy and quick setting on the glass surface or the display</li> </ul>	 <p><b>ZEITSPAREND</b></p> <ul style="list-style-type: none"> <li>• Deutlich schneller als Elektroherde</li> </ul> <p><b>TIME-SAVING</b></p> <ul style="list-style-type: none"> <li>• Much faster than electric stoves</li> </ul>	 <p><b>ENERGIESPAREND</b></p> <ul style="list-style-type: none"> <li>• Schnelles und direktes Erhitzen</li> <li>• Umweltschonend</li> </ul> <p><b>ENERGY-SAVING</b></p> <ul style="list-style-type: none"> <li>• Fast and direct heating</li> <li>• Environmentally friendly</li> </ul>	 <p><b>ÜBERALL EINSETZBAR</b></p> <ul style="list-style-type: none"> <li>• Alle Induktionsgeräte mit 230 Volt-Schuko-Stecker</li> <li>• Kabellänge: 1,4 m</li> </ul> <p><b>USEABLE EVERYWHERE</b></p> <ul style="list-style-type: none"> <li>• All induction devices with 230 volt safety plug</li> <li>• Cable length: 1.4 m</li> </ul>



DE	INDUKTIONSKOCHFELD "COOK 500"
EN	INDUCTION HOB "COOK 500"
IT	PIASTRA AD INDUZIONE "COOK 500"
ES	PLACA DE INDUCCIÓN "COOK 500"

- |   |   |
|---|---|
| <ul style="list-style-type: none"> <li>• Edelstahlgehäuse</li> <li>• Starke Glaskeramik-Oberfläche</li> <li>• Touchbedienfeld mit Digitalanzeige</li> <li>• Heizstufen: 1–10 (500–3500 W)</li> <li>• Spannung: 230 V, 50/60 Hz</li> <li>• Temperatur: 60–240 °C</li> <li>• Timerfunktion: bis 180 min.</li> </ul> | <ul style="list-style-type: none"> <li>• Stainless steel case</li> <li>• Strong glass ceramic surface</li> <li>• Touch control panel with digital display</li> <li>• Heating levels: 1–10 (500–3500 W)</li> <li>• Voltage: 230 V, 50/60 Hz</li> <li>• Temperature: 60–240 °C</li> <li>• Timer function: up to 180 min.</li> </ul> |
|---|---|

#	↔ mm	⏏	⚖ kg
147200	425 x 330 x 105	3500	6,0





DE	BRATPFANNE									
EN	FRYING PAN	SST	+400 °C		CERAMIC	ELECTRO	GAS	INDUCTION		
IT	PADELLA									
ES	SARTÉN									

- Sandwichboden
- Mit Antihftbeschichtung
- Angeschweißter Kaltgriff
- Sandwich base
- With non-stick coating
- Welded-on cold handle

#	Ø mm	↑ mm	↓ mm	↓ mm
<input checked="" type="checkbox"/> 531050	240	58	2,0	0,8
<input checked="" type="checkbox"/> 531051	280	62	3,6	0,8
<input checked="" type="checkbox"/> 531052	320	66	4,8	0,8

**i** Reinigung in der Spülmaschine kann die Lebensdauer verringern! /  
Cleaning in the dishwasher may reduce the service life!



#531051

DE	BRATPFANNE									
EN	FRYING PAN	ALU	SST	+260 °C		CERAMIC	ELECTRO	GAS	INDUCTION	
IT	PADELLA									
ES	SARTÉN									

- Sandwichboden
- Mit Antihftbeschichtung
- Angeschweißter Kaltgriff
- Sandwich base
- With non-stick coating
- Welded-on cold handle

#	Ø mm	↑ mm	↓ mm	↓ mm
<input checked="" type="checkbox"/> 531070	240	35	1,4	3,5
<input checked="" type="checkbox"/> 531071	280	45	2,0	3,5
<input checked="" type="checkbox"/> 531072	320	47	2,8	3,5

**i** Reinigung in der Spülmaschine kann die Lebensdauer verringern! /  
Cleaning in the dishwasher may reduce the service life!



#531070

**Sandwichboden /  
Sandwich base**

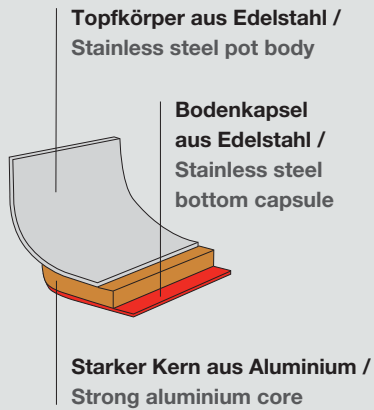

DE	KOCHTOPF	SST	- 25 +400 °C	CERAMIC	ELECTRO	GAS	INDUCTION	DISHWASHER SAFE
EN	STOCKPOT							
IT	PENTOLA							
ES	OLLA							



#531006

- Sandwichboden
- Mit Schüttrand
- Angeschweißte Kaltgriffe
- Sandwich base
- With pouring rim
- Welded-on cold handles

#	Ø mm	↑ mm	↓ mm	↓ mm	
531000	160	160	3,1	0,8	
531001	200	200	6,1	0,8	
531002	240	240	11,0	0,8	
531003	280	280	17,0	0,8	
531004	320	320	25,0	0,8	
531005	360	360	33,0	1,0	
531006	400	400	49,0	1,0	

DE	FLEISCHTOPF	SST	- 25 +400 °C	CERAMIC	ELECTRO	GAS	INDUCTION	DISHWASHER SAFE
EN	STEW POT							
IT	PENTOLA PER CARNE							
ES	OLLA PARA CARNE							

- Sandwichboden
- Mit Schüttrand
- Angeschweißte Kaltgriffe
- Sandwich base
- With pouring rim
- Welded-on cold handles



#531015

#	Ø mm	↑ mm	↓ mm	↓ mm	
531010	160	110	2,1	0,8	
531011	200	130	4,0	0,8	
531012	240	150	6,6	0,8	
531013	280	170	10,0	0,8	
531014	320	200	16,0	0,8	
531015	360	220	21,0	1,0	

DE	BRATENTOPF							
EN	STEW POT	SST	-25 +400 °C	CERAMIC	ELECTRO	GAS	INDUCTION	
IT	PENTOLA PER ARROSTO							
ES	OLLA DE ESTOFADO							

- Sandwichboden
- Mit Schüttrand
- Angeschweißte Kaltgriffe
- Sandwich base
- With pouring rim
- Welded-on cold handles

#	Ø mm	↑ mm	↓ mm	↓ mm
531020	160	80	1,6	0,8
531021	200	90	2,7	0,8
531022	240	100	4,4	0,8
531023	280	120	7,2	0,8
531024	320	150	12,0	0,8



#531020

DE	STIELKASSEROLLE							
EN	SAUCEPAN	SST	-25 +400 °C	CERAMIC	ELECTRO	GAS	INDUCTION	
IT	CASSERUOLA							
ES	CACEROLA							

- Sandwichboden
- Mit Schüttrand
- Angeschweißter Kaltgriff
- Sandwich base
- With pouring rim
- Welded-on cold handle

#	Ø mm	↑ mm	↓ mm	↓ mm
<input checked="" type="checkbox"/> 531030	160	70	1,4	0,8
<input checked="" type="checkbox"/> 531031	180	80	2,0	0,8
<input checked="" type="checkbox"/> 531032	200	90	2,8	0,8



#531031

DE	SAUTEUSE							
EN	SAUTEUSE	SST	-25 +400 °C	CERAMIC	ELECTRO	GAS	INDUCTION	
IT	SAUTEUSE							
ES	SAUTEUSE							

- Sandwichboden
- Angeschweißter Kaltgriff
- Sandwich base
- Welded-on cold handle

#	Ø mm	↑ mm	↓ mm	↓ mm
<input checked="" type="checkbox"/> 531040	160	60	1,0	0,8
<input checked="" type="checkbox"/> 531041	180	60	1,2	0,8
<input checked="" type="checkbox"/> 531042	200	65	1,6	0,8



#531041

DE	DECKEL							
EN	LID		SST	-25 +400 °C				
IT	COPERCHIO							
ES	TAPA							

- Mit Griff
- With handle

#	Ø mm	↑ mm	↓ mm
531060	160	45	0,8
531061	200	45	0,8
531062	240	45	0,8
531063	280	45	0,8
531064	320	50	0,8
531065	360	50	0,8
531066	400	50	0,8



#531063



DE	VORLEGEBESTECK HITZEBESTÄNDIG
EN	CUTLERY, HEAT-RESISTANT
IT	UTENSILI RESISTENTI AL CALORE
ES	CUBERTERÍA REFRACTARIA

Material: PPA, schwarz

Made of PPA, black

• Hitzebeständig bis + 270 °C (\*+ 220 °C)

• Heat resistant up to + 270 °C (\*+ 220 °C)

#		↗ mm	↔ mm / Ø
<input checked="" type="checkbox"/> 172460	Bratgutwender / slotted turner	310	85
<input checked="" type="checkbox"/> 172461	Suppenkelle / soup ladle	300	90 x 35
<input checked="" type="checkbox"/> 172462	Spaghettilöffel / spaghetti spoon	300	72
<input checked="" type="checkbox"/> 172463	Schaumlöffel / skimmer	325	108
<input checked="" type="checkbox"/> 172464	Servierlöffel / serving spoon	300	65
<input checked="" type="checkbox"/> 172465	Kochlöffel / cooking spoon	300	62
<input checked="" type="checkbox"/> 172370	Pinzette* / kitchen pincers*	305	18

\* hitzebeständig bis + 220 °C / heat resistant up to + 220 °C



DE	SPACHTELN
EN	SPATULAS
IT	SPATOLE TRIANGOLARI INOX CON MANICO NERO
ES	ESPÁTULAS TRIANGULARES, MANGO NEGRO

Material: Edelstahl,  
Kunststoffgriff schwarz (PP)

Made of stainless steel,  
black plastic handle (PP)

#	→ mm
<input checked="" type="checkbox"/> 200500	40
<input checked="" type="checkbox"/> 200501	60
<input checked="" type="checkbox"/> 200502	80
<input checked="" type="checkbox"/> 200503	100
<input checked="" type="checkbox"/> 200504	120



DE	VORLEGEBESTECK
EN	CUTLERY
IT	UTENSILI
ES	CUBERTERÍA

Material: Edelstahl

- Poliert
- Fugenlos

Made of stainless steel

- Polished
- Seamless

#		↗ mm	↔ mm / Ø	ml 	
<input checked="" type="checkbox"/> 175000	Saucenlöffel / Spoon	315	60 x 80		
<input checked="" type="checkbox"/> 175001	Schaumlöffel / Skimmer	315	85		
<input checked="" type="checkbox"/> 175002	Pfannenwender / Spatula	375	72 x 90		
<input checked="" type="checkbox"/> 175003	Pfannenwender, geschlitzt / Spatula slotted	375	72 x 90		
<input checked="" type="checkbox"/> 175004	Schöpfkelle / Ladle	340	85	30	
<input checked="" type="checkbox"/> 175005	Saucenlöffel / Sauce ladle	270	60	100	
<input checked="" type="checkbox"/> 175006	Servierlöffel / Spoon	340	60 x 90		
<input checked="" type="checkbox"/> 175007	Servierlöffel gelocht / Spoon perforated	340	60 x 90		





DE	SCHÖPFKELLEN
EN	LADLE
IT	MESTOLO
ES	CACILO

Material: Edelstahl  
 • Fugenlos  
 • Materialstärke: 3 mm

Made of stainless steel  
 • Seamless  
 • Thickness: 3 mm

#	↗ mm	Ø mm	l mm
<input checked="" type="checkbox"/> 175030	300	65	0,07
<input checked="" type="checkbox"/> 175032	320	80	0,125
<input checked="" type="checkbox"/> 175033	330	90	0,2
<input checked="" type="checkbox"/> 175037	370	100	0,25
<input checked="" type="checkbox"/> 175040	400	110	0,33
<input checked="" type="checkbox"/> 175043	430	120	0,5
<input checked="" type="checkbox"/> 175044	440	140	0,75
<input checked="" type="checkbox"/> 175047	470	160	1,0



DE	SCHAUMLÖFFEL
EN	SKIMMER
IT	SCHIUMAROLA
ES	ESPUMADERA

Material: Edelstahl, 3 mm  
 • Fugenlos  
 • Gelocht  
 • Breiter und flacher Boden  
 • Materialstärke: 3 mm

Made of stainless steel, 3 mm  
 • Seamless  
 • Perforated  
 • Wide and flat bottom  
 • Thickness: 3 mm

#	↗ mm	Ø mm
<input checked="" type="checkbox"/> 176080	290	80
<input checked="" type="checkbox"/> 176100	320	100
<input checked="" type="checkbox"/> 176120	350	120
<input checked="" type="checkbox"/> 176140	380	140
<input checked="" type="checkbox"/> 176160	410	160
<input checked="" type="checkbox"/> 176180	430	180



DE	FRITTIERSCHAUFEL
EN	WIRE SKIMMER
IT	SCHIUMAROLA A FILO
ES	ESPUMADERAS A MALLA

Material: Edelstahl  
 • Verstärkter Drahtgriff

Made of stainless steel  
 • Reinforced wire handle

#	↗ mm	Ø mm
<input checked="" type="checkbox"/> 178000	480	160
<input checked="" type="checkbox"/> 178001	560	180
<input checked="" type="checkbox"/> 178002	560	200
<input checked="" type="checkbox"/> 178003	640	220
<input checked="" type="checkbox"/> 178004	640	240
<input checked="" type="checkbox"/> 178005	650	260

DE	SERVIERLÖFFEL
EN	SERVING SPOON
IT	CUCCHIAIONI
ES	CUCHARÓN

- Material: Edelstahl
- Fugenlos
  - Materialstärke: 3 mm

- Made of stainless steel
- Seamless
  - Thickness: 3 mm

#	↗ mm	↔ mm
<input checked="" type="checkbox"/> 177040	330	
<input checked="" type="checkbox"/> 177041	450	
<input checked="" type="checkbox"/> 177042	480	

<input checked="" type="checkbox"/> 177050	460 / 380	95 x 70
--	-----------	---------



DE	SERVIERLÖFFEL – GELOCHT
EN	SERVING SPOON – PERFORATED
IT	CUCCHIAIONI
ES	CUCHARÓN

- Material: Edelstahl
- Fugenlos
  - Gelocht
  - Materialstärke: 3 mm

- Made of stainless steel
- Seamless
  - Perforated
  - Thickness: 3 mm

#	↗ mm
<input checked="" type="checkbox"/> 177030	330
<input checked="" type="checkbox"/> 177031	450
<input checked="" type="checkbox"/> 177032	480



DE	PFANNENWENDER
EN	SPATULA
IT	PALETTA
ES	ESPÁTULA

- Material: Edelstahl
- Fugenlos
  - Materialstärke: 3 mm

- Made of stainless steel
- Seamless
  - Thickness: 3 mm

#		↗ mm
<input checked="" type="checkbox"/> 177010	geschlossen / closed	380
<input checked="" type="checkbox"/> 177011	geschlitzt / slotted	380





DE	SAUCENLÖFFEL
EN	SPOON, CROSSWISE
IT	CUCCHIAIONE OBLIQUO
ES	CUCHARÓN OBLIQUO

Material: Edelstahl  
 • Fugenlos  
 • Materialstärke: 3 mm

Made of stainless steel  
 • Seamless  
 • Thickness: 3 mm

#	↗ mm	
<input checked="" type="checkbox"/> 177020	330	
<input checked="" type="checkbox"/> 177021	450	
<input checked="" type="checkbox"/> 177022	480	



DE	SPAGHETTLÖFFEL
EN	SPAGHETTI SPOON
IT	CUCCHIAIO PER SPAGHETTI
ES	TENEDOR ESPAGUETTIS

Material: Edelstahl  
 • Fugenlos  
 • Materialstärke: 3 mm

Made of stainless steel  
 • Seamless  
 • Thickness: 3 mm

#	↗ mm	Ø mm
<input checked="" type="checkbox"/> 177060	395 / 300	95 x 85



DE	FLEISCHGABEL
EN	MEAT FORK
IT	FORCHETTONE
ES	TENEDOR

Material: Edelstahl  
 • Fugenlos  
 • Materialstärke: 3 mm

Made of stainless steel  
 • Seamless  
 • Thickness: 3 mm

#	Zacken / Prongs	↗ mm	↔ mm
<input checked="" type="checkbox"/> 177002	2	560 / 430	125 x 30
<input checked="" type="checkbox"/> 177003	3	560 / 430	125 x 40



DE	PASSIERSIEBE
EN	GOURMET SIEVES
IT	COLINI PASSABRODO
ES	COLADORES DE CALDO

- Material: Edelstahl
- Mit Griff und Auflagehaken
  - **Extra breiter Rand**

- Made of stainless steel
- With handle and hook
  - **Extra-wide rim**



#	Ø mm	⊞ mm	
<input checked="" type="checkbox"/> 199328	180	0,84	

- Material: Edelstahl
- Mit Griff und Auflagehaken

- Made of stainless steel
- With handle and hooks



#	Ø mm	⊞ mm	
<input checked="" type="checkbox"/> 199331	300	1,5	

- Material: Edelstahl
- Mit Griff und Auflagehaken

- Made of stainless steel
- With handle and hooks

#	Ø mm	⊞ mm	
<input checked="" type="checkbox"/> 199370	160	1,5	
<input checked="" type="checkbox"/> 199371	180	1,5	
<input checked="" type="checkbox"/> 199372	200	1,5	
<input checked="" type="checkbox"/> 199373	220	1,5	
<input checked="" type="checkbox"/> 199374	240	1,5	
<input checked="" type="checkbox"/> 199375	260	1,5	



DE	GROSSKÜCHENSIEBE
EN	BOWL STRAINERS
IT	COLAPASTA RINFORZATI
ES	COLADORES REFORZADOS

- Material: Edelstahl
- Mit Schutzbügel

- Made of stainless steel
- With guard



#		Ø mm	⊞ mm	
<input checked="" type="checkbox"/> 198840		260	1,5	
198841	Ersatzsieb / Spare strainer	260	1,5	





DE	KÜCHENSIEBE / PASSIERSIEBE
EN	SAUCE STRAINERS
IT	COLATUTTO
ES	COLADORES

Material: Edelstahl

Made of stainless steel

#	Ø mm	↑ mm	⊞ mm
<input checked="" type="checkbox"/> 198870	80	30	1,0
<input checked="" type="checkbox"/> 198871	100	35	1,0
<input checked="" type="checkbox"/> 198872	120	50	1,5
<input checked="" type="checkbox"/> 198873	150	50	1,5
<input checked="" type="checkbox"/> 198874	180	65	1,5
<input checked="" type="checkbox"/> 198875	200	70	1,5



DE	GOURMET-PASSIERSIEBE
EN	GOURMET BOUILLON-SIEVES
IT	COLINI PASSABRODO
ES	COLADORES DE CALDO

Material: feinmaschiges Nylonnetz

Made of fine woven nylon cloth

- Zum Abseihen feiner Saucen, Dämpfen, Einmachen etc.
- Spülmaschinengeeignet
- Hitzebeständig bis +150 °C

- Kitchen net for straining, steaming, jam making etc.
- Dishwasher proof
- Heat-resistant up to +150 °C

#	Ø mm
<input checked="" type="checkbox"/> 199095	200
<input checked="" type="checkbox"/> 199096	240
<input checked="" type="checkbox"/> 199097	280
<input checked="" type="checkbox"/> 199098	350



DE	SPITZSIEB
EN	CHINESE COLANDER
IT	CORNETTI CINESI
ES	COLADORES CHIONOS

Material: Edelstahl

Made of Stainless steel

- Mit Randhalterung
- 2 mm Lochung

- With rim holder
- 2 mm perforation

#	Ø mm	↔ mm
<input checked="" type="checkbox"/> 178010	180	405 x 190 x 165
<input checked="" type="checkbox"/> 178011	200	420 x 210 x 180
<input checked="" type="checkbox"/> 178012	240	460 x 250 x 225

DE	STREUER
EN	SHAKER
IT	SPARGITORE
ES	ESPARCIDOR

Material: Aluminium  
 • Mit Schraubdeckel

Made of aluminium  
 • With screw cap

#	Ø mm	↑ mm
198890	80	190



DE	POMMES FRITES / ABTROPFSCHÜSSEL
EN	FRENCH FRIES COLANDER
IT	COLAFRITTO PER PATATINE FRITTE
ES	COLADOR PATATAS FRITAS

Material: Edelstahl  
 • Mit Griffen  
 • Abnehmbare Auffangschale

Made of stainless steel  
 • With handles  
 • Detachable drip tray

#	Ø mm	↑ mm
198891	410	140



DE	KARTOFFELSTAMPFER
EN	POTATO MASHER
IT	SCHIACCIAPATATE
ES	PRENSADOR DE PATATAS

Material: Edelstahl  
 • Extra schwere Qualität

Made of stainless steel  
 • Extra heavy quality

#	↗ mm
198892	580

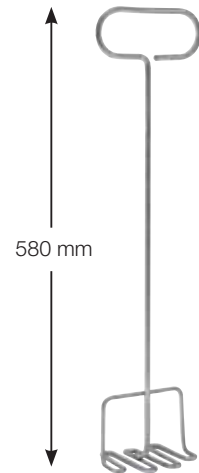

DE	RÜHRSPATELN
EN	MIXING PADDLES
IT	SPATOLE
ES	ESPÁTULAS

Material: PP, weiß  
 • Hitzebeständig bis 100°C  
 • Perforiert

Made of PP, white  
 • Heat resistant up to 100° C  
 • Perforated

#	↗ mm
228128	1000
228129 *	1200





DE	VIERKANTREIBE / UNIVERSALREIBE
EN	GRATER
IT	GRATTUGIA UNIVERSALE
ES	RALLADOR UNIVERSAL











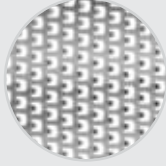

- Material: Edelstahl
- 4 verschiedene Reibeflächen
  - Inklusive rutschhemmende Füße

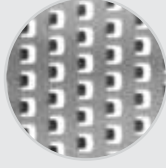
- Made of stainless steel
- 4 different grating surfaces
  - Including anti-slip feet



#	↓ mm	→ mm	↑ mm	
151145	85	110	250	

DE	REIBEN
EN	GRATERS
IT	GRATTUGIE
ES	RALLADORES

		#		↔ mm
<b>1. Hobel / slicer</b> 	Schokolade, harter Käse, Gurken, Knoblauch, Ingwer, Trüffel, Butter / Chocolate, hard cheeses, cucumbers, garlic, ginger, truffles, butter	292000		75 x 320
		<input checked="" type="checkbox"/>		
<b>2. fein / fine</b> 	Zitrusfrüchte, Gewürze / Citrus zest, spices	292001		75 x 320
		<input checked="" type="checkbox"/>		
<b>3. grob / coarse</b> 	Käse, Karotten, Kokos, Schokolade / Hard cheeses, carrots, coconut, chocolate	292003		75 x 320
		<input checked="" type="checkbox"/>		
<b>4. sehr grob / extra coarse</b> 	Zucchini, Kartoffeln, weicher Käse, Karotten, Äpfel, Kohl / Zucchini, potatoes, soft cheeses, carrots, apples, cabbage	292004		45 x 390
		<input checked="" type="checkbox"/>		
<b>5. Stern / star</b> 	harter Käse, Zitrusfrüchte, Knoblauch, Muskatnuss / hard cheeses, citrus zest, garlic, nutmeg	292005		75 x 320
		<input checked="" type="checkbox"/>		
		292006		45 x 390
		<input checked="" type="checkbox"/>		
		292007		75 x 320
		<input checked="" type="checkbox"/>		
		292008		45 x 390
		<input checked="" type="checkbox"/>		



Silikon-Stabilitätsfuß für stabiles Arbeiten / Silicone stability foot for stable work.

Säuregeätzte Klingen sorgen für eine scharfe Schneidefläche, die länger scharf bleibt / Acid etched blades for a super sharp cutting surface that stays sharp longer.

Ergonomischer Griff, mit Aufhängeloch / with comfortable ergonomic handle, with hanging hole.



DE	RÜHRSCHÜSSELN	
EN	MIXING BOWLS	
IT	CIOTOLE TONDE	
ES	CALDEROS SEMIESFÉRICOS	



- Material: PP, natur-weiß
- Bruchsicher
  - Hygienisch
  - Stapelbar
  - Für Mikrowellengeräte geeignet

- Made of PP, natural white
- Break resistant
  - Hygienic
  - Stackable
  - Suitable for microwave

#	↑ mm	Ø mm	↑ mm
290000	1,0	190	79
290010	2,5	240	115
290020	4,5	280	135
290030	6,0	325	147
290040	9,0	360	165
290050	13,0	400	185



DE	DECKEL
EN	LIDS
IT	COPERCHI
ES	TAPAS

Material: PP

Made of PP

#	für/for #	Ø mm
290070	290000 (1,0 l)	190
290071	290010 (2,5 l)	240
290072	290020 (4,5 l)	280
290073	290030 (6,0 l)	325
290074	290040 (9,0 l)	360
290075	290050 (13,0 l)	400

DE	KASSEROLLE	
EN	SAUCEPAN	
IT	CARAFFA GRADUATA PER MICROONDE	
ES	CAZO DE POLIPROPILENO PARA MICROONDAS	



- Material: PP, weiß
- Mit geprägter Skala in Innenseite
  - Blauer Skalendruck auf der Außenseite
  - Bruchsicher
  - Hygienisch
  - Für Mikrowellengeräte geeignet

- Made of PP, white
- Inside scale
  - Blue stamped litre and ml scale outside
  - Break resistant
  - Hygienic
  - Suitable for microwave

#	↗ mm	Ø mm	↑ mm	↑ mm
290200	335	190	120	2,0

 Ausgießer beidseitig somit für Links- und Rechtshänder geeignet. / Pour spouts on both sides, thus for left- and right-handers.

DE	FRÜCHTE ABLAUF-SET, RUND
EN	FRUIT STRAINER SET, ROUND
IT	SET SCOLAFRUTTA
ES	JUEGO DE COLADOR PARA FRUTA

Material: PP, weiß

- Bruchsicher
- Hygienisch
- Sieb mit praktischem Griff
- Alle Komponenten einzeln erhältlich

Made of PP, white

- Break resistant
- Hygienic
- Stackable, strainer with 2 handles
- Each part available separately



#		Ø mm	
290040	Schüssel/ bowl	360	9,0
200022	Seiher/strainer	280	

DE	SEIHER
EN	STRAINER
IT	COLAPASTA IN PLASTICA
ES	COLADOR, PLÁSTICO

Material: PP, weiß

- 2 Muschelgriffe
- Passende Schüssel  
# 221026+290040

Made of PP, white

- With 2 shell shaped handles
- Corresponding bowl  
# 221026+290040



#	↑ Ø mm	↓ Ø mm	↑ mm
200022	360	280	185

DE	RÜHRSCHÜSSEL
EN	MIXING BOWL
IT	CIOTOLA IN PLASTICA
ES	CALDERO BOL, PLÁSTICO

Material: ABS, weiß

- Ausgießer
- Praktischem Handgriff
- Ringfuß, antirutsch

Made of ABS, white

- Sprout
- Convenient handle
- Nonslip base



#		Ø mm	
290300	Schüssel/ Bowl	240	4,25

DE	ZUTATENBEHÄLTER / VORRATSBEHÄLTER
EN	FOOD STORAGE CONTAINERS WITH LIID
IT	CONTENITORI CON COPERCHIO
ES	CONTENEDORES CON TAPA



Material: PP

- Mit Klappdeckel (PC)
- Spülmaschinengeeignet

Made of PP

- With lid (PC)
- Dishwasher proof



#	↔ mm	
230150	500 x 160 x 95	4 x 0,7
230160	500 x 160 x 95	6 x 0,45

DE	RÜHRSCHÜSSELN	SST
GB	MIXING BOWLS	
IT	BACINELLE CONICHE	
ES	CALDEROS CÓNICOS	



- **Konische Form**
- Mit abgerundetem Rand
- Glatter Boden
- Gute Standfestigkeit
- Stabil und griffig
- Stapelbar

- **Conical shape**
- With rolled edge
- Smooth bottom
- Good stability
- Stable and non-slip
- Stackable



#	Ø mm	l	
199002	160	0,5	
199003	180	0,9	
199004	200	1,2	
199005	225	1,6	
199006	235	2,0	
199007	280	3,0	
199008	320	5,0	
199009	360	7,0	
199010	395	8,2	

DE	SCHLAGSCHÜSSELN	SST
GB	MIXING BOWLS	
IT	BACINELLE SEMISFERICHE	
ES	CALDEROS SEMIESFÉRICOS	



- **Runde Form**
- Mit abgerundetem Rand
- Glatter Boden
- Gute Standfestigkeit
- Stabil und griffig
- Stapelbar

- **Hemispherical shape**
- With rolled edge
- Smooth bottom
- Good stability
- Stable and non-slip
- Stackable



#	Ø mm (innen/inside)	l	
199000	125	0,3	
199011	140	0,5	
199012	165	0,9	
199013	185	1,25	
199014	200	1,85	
199015	230	2,6	
199017	255	3,2	
199018	280	4,5	
199019	330	8,5	

DE	MESSBECHER
EN	MEASURING CUPS
IT	CARAFFE GRADUATE
ES	JARRAS GRADUADAS

Material: PP, Farbe natur

- Mit geprägter Skala und blauer Skala
- Liter- und Milliliter-Einteilung
- Bis 95°C erhitzzbar

Made of PP, translucent

- With stamped and blue scale
- Litre and ml scale
- Temperature resistant up to 95°C

#	mit geschlossenem Griff / with closed handle	l	
206010*	ohne Griff / without handle	0,12	
200011	mit geschlossenem Griff / closed handle	0,5	
200012	mit geschlossenem Griff / closed handle	1,0	
200013	mit geschlossenem Griff / closed handle	2,0	
200014	mit geschlossenem Griff / closed handle	3,0	
200015	mit geschlossenem Griff / closed handle	5,0	



# 206010

#	mit offenem Griff / with open handle	l	
200010*	mit offenem Griff / open handle	0,25	
206011	mit offenem Griff / open handle	0,5	
206012	mit offenem Griff / open handle	1,0	
206013	mit offenem Griff / open handle	2,0	
206014	mit offenem Griff / open handle	3,0	
206015	mit offenem Griff / open handle	5,0	



# 200010

\* nur geprägte Skala

\* only with stamped scale

#	Deckel für # / Lid for #	
206112	200012 + 206012 / 1,0 l	
206113	200013 + 206013 / 2,0 l	
206114	200014 + 206014 / 3,0 l	
206115	200015 + 206015 / 5,0 l	



Material: PP, Farbe natur

- Mit offenem Griff
- Stapelbar
- Liter- und Milliliter-Einteilung
- Bis 95°C erhitzzbar

Made of PP, translucent

- With open handle
- Stackable
- With litre- and ml-scale
- temperature resistant up to 95°C

#	l	
200149	0,5	
200150	1,0	
200170	2,0	
200179	3,0	



DE	MESSBECHER-SET – mit geschlossenem Griff / inklusive Deckel
EN	SET OF MEASURING CUPS – with closed handle / including lid
IT	SET DI CARAFFE GRADUATE
ES	SET DE JARRAS GRADUADAS

Material: PP, Farbe natur

- Mit geprägter Skala und blauer Skala
- Liter- und Milliliter-Einteilung
- Bis 95°C erhitzzbar

Made of PP, translucent

- With stamped and blue scale
- Litre and ml scale
- Temperature resistant up to 95°C

#		l	
200408	mit geschlossenem Griff / closed handle	1,0	
200409	mit geschlossenem Griff / closed handle	2,0	





DE	FLACHBESEN	
EN	FLAT WHISK	
IT	FRUSTA PIATTA	
ES	BATIDOR PLANO	

- Speziell für das Unterheben von schweren Massen und Saucen, Cremes und Mehl
  - Auch bestens für Fettgebäck geeignet
  - Especially for mixing heavy masses and sauces, creams and flour
  - Also ideally suitable for fatty pastries
- Drahtstärke: 2,0 mm**      **Wire thickness: 2.0 mm**

#	↗ mm	Drähte / Wires
<input checked="" type="checkbox"/> 170079	270	4



DE	SCHNEEBESEN	
EN	WHISKS	
IT	FRUSTE	
ES	BATIDORES	

- Schwarzer thermoplastischer Griff
  - Drähte aus Edelstahl
  - Wasserdichter Griff
  - Mit Aufhängeöse
  - Schwere Qualität
  - Hitzebeständig bis 150°C
  - Black thermoplastic handle
  - Wires made of stainless steel
  - Waterproof handle
  - With suspension eye
  - Heavy quality
  - Heat resistant up to 150°C
- Drahtstärke: 1,6 mm**      **Wire thickness: 1.6 mm**

#	↗ mm	Drähte / Wires
<input checked="" type="checkbox"/> 170080	250	24
<input checked="" type="checkbox"/> 170081	300	24
<input checked="" type="checkbox"/> 170082	350	24
<input checked="" type="checkbox"/> 170083	400	24
<input checked="" type="checkbox"/> 170084	450	24
<input checked="" type="checkbox"/> 170085	500	24



- Material: Edelstahl      Made of stainless steel
- Handlicher Griff
  - Für leichte Massen
  - Easy-to-hold handle
  - For light masses
- Drahtstärke: 1,6 mm**      **Wire thickness: 1.6 mm**

#	↗ mm	Drähte / Wires
<input checked="" type="checkbox"/> 170040	250	24
<input checked="" type="checkbox"/> 170041	300	24
<input checked="" type="checkbox"/> 170042	350	24
<input checked="" type="checkbox"/> 170043	400	24
<input checked="" type="checkbox"/> 170044	450	24



- BALLONFORM
  - Schwarzer Kunststoffgriff "Exoglass"
  - Drähte aus Edelstahl
  - Wasserdichter Griff
  - Griffbund verhindert abrutschen
  - Hitzebeständig bis 220 °C
  - BALLOON-SHAPE
  - Black plastic handle "Exoglass"
  - Wires made of stainless steel
  - Waterproof handle
  - Handle band prevents slipping
  - Heat resistant up to 220 °C
- Drahtstärke: 1,5 mm**      **Wire thickness: 1.5 mm**

#	↗ mm	Drähte / Wires
170016	450	24

DE	RÜHRBESEN	
EN	WHISKS	
IT	FRUSTE	
ES	BATIDORES	

- |   |   |
|---|---|
| <ul style="list-style-type: none"> <li>• Schwarzer thermoplastischer Griff</li> <li>• Drähte aus Edelstahl</li> <li>• Wasserdichter Griff</li> <li>• Mit Aufhängeöse</li> <li>• Schwere Qualität</li> <li>• Hitzebeständig bis 150°C</li> </ul> <p><b>Drahtstärke: 2,0 mm</b></p> | <ul style="list-style-type: none"> <li>• Black thermoplastic handle</li> <li>• Wires made of stainless steel</li> <li>• Waterproof handle</li> <li>• With suspension eye</li> <li>• Heavy quality</li> <li>• Heat resistant up to 150°C</li> </ul> <p><b>Wire thickness: 2.0 mm</b></p> |
|---|---|



#	↗ mm	Drähte / Wires
<input checked="" type="checkbox"/> 170070	250	16
<input checked="" type="checkbox"/> 170071	300	16
<input checked="" type="checkbox"/> 170072	350	16
<input checked="" type="checkbox"/> 170073	400	16
<input checked="" type="checkbox"/> 170074	450	16
<input checked="" type="checkbox"/> 170075	500	16

- |   |   |
|---|---|
| <p>Material: Edelstahl</p> <ul style="list-style-type: none"> <li>• Handlicher Griff</li> <li>• Für schwere Massen</li> </ul> <p><b>Drahtstärke: 2,3 mm</b></p> | <p>Made of stainless steel</p> <ul style="list-style-type: none"> <li>• Easy-to-hold handle</li> <li>• For heavy masses</li> </ul> <p><b>Wire thickness: 2.3 mm</b></p> |
|---|---|



#	↗ mm	Drähte / Wires
<input checked="" type="checkbox"/> 170050	350	16
<input checked="" type="checkbox"/> 170051	400	16
<input checked="" type="checkbox"/> 170052	450	16
<input checked="" type="checkbox"/> 170053	500	16
<input checked="" type="checkbox"/> 170054	600	16

- |   |  |
|---|--|
| <ul style="list-style-type: none"> <li>• Schwarzer Kunststoffgriff "Exoglass"</li> <li>• Drähte aus Edelstahl</li> <li>• Wasserdichter Griff</li> <li>• Griffbund verhindert abrutschen</li> <li>• Hitzebeständig bis 220 °C</li> </ul> <p><b>Drahtstärke: 1,8 mm</b></p> | <ul style="list-style-type: none"> <li>• Black plastic handle "Exoglass"</li> <li>• Wires made of stainless steel</li> <li>• Waterproof handle</li> <li>• Handle band prevents slipping</li> <li>• Heat resistant up to 220 °C</li> </ul> <p><b>Wire thickness: 1.8 mm</b></p> |
|---|--|



#	↗ mm	Drähte / Wires
170010	250	12
170011	300	16
170012	350	16
170013	400	16
170014	450	18
170015	500	18



DE	PASTETENAUSSTECHE
EN	CUTTERS FOR PATE
IT	TAGLIAPASTA PER PATÉ
ES	CORTADOR PARA PATÉ



Material: Edelstahl

- Materialstärke: 0,4 mm
- Höhe: 50 mm

Made of stainless steel

- thickness: 0,4 mm
- Height: 50 mm

#	→□← mm	↔ mm	
199892	66	40	
199893	Pastetenhalter/mould	40	
199894	73	47	
199895	Pastetenhalter/mould	45	



DE	STREUER / GEWÜRZDOSE / ZUCKERSTREUER	SST
EN	SUGAR DISPENSERS	
IT	SPARGIZUCCHERO	
ES	ESPARCIDORES DE AZÚCAR CON TAMIZ	

Material: Edelstahl

Made of stainless steel

#		↑ mm	∅ mm	⊞ mm	⌞ mm	
199026	mit Sieb / with meshes	76	56	0,8	0,15	
199027	mit Sieb / with meshes	89	68	0,8	0,25	
199028	mit Sieb / with meshes	127	68	0,8	0,35	
199059	kleine Lochung / small holes	79	56	1,5	0,15	
199060	kleine Lochung / small holes	91	68	1,5	0,25	
199061	kleine Lochung / small holes	129	68	1,5	0,35	
199065	große Lochung / large holes	79	56	2,5	0,15	
199063	große Lochung / large holes	91	68	2,5	0,25	
199064	große Lochung / large holes	129	68	2,5	0,35	



199026 / 199059 / 199065  
mit Bajonettverschluss /  
with bayonet lock



alle anderen  
Größen mit Dreh-  
verschluss /  
with screw lock

DE	BACKHANDSCHUHE SILIKON	
EN	BAKING MITTENS SILICONE	
IT	GUANTI DA FORNO IN SILICONE	
ES	GUANTES MANOPLAS DE SILICONA PARA HORNO 3 DEDOS	

- |  |   |
|--|---|
| <p>100% Silikon</p> <ul style="list-style-type: none"> <li>• Hitzebeständig bis +250°C / max. 15 sec.</li> <li>• Flexibles Material</li> <li>• Wasserdicht</li> <li>• Spülmaschinengeeignet</li> <li>• Hygienisch</li> <li>• Sterilisierbar</li> </ul> | <p>100% silicone</p> <ul style="list-style-type: none"> <li>• Heat resistant up to +250°C / max. 15sec.</li> <li>• Flexible material</li> <li>• Waterproof</li> <li>• Dishwasher safe</li> <li>• Hygienic</li> <li>• Can be sterilised</li> </ul> |
|--|---|

#	↗ mm	→ mm	
310031	285	160	
310032	385	180	



DE	GASTROHANDSCHUH „SILIKON“	
EN	GASTRO MITTENS „SILICONE“	
IT	GUANTI GASTRO IN „SILICONE“	
ES	MANOPLAS GASTRO „SILICONA“	

- |  |   |
|--|---|
| <p>Material: Silikon mit Baumwollfutter</p> <ul style="list-style-type: none"> <li>• Für Rechts- und Linkshänder</li> <li>• Zwischen Daumen und Zeigefinger verstärkt</li> <li>• Wasserdicht</li> <li>• Flexibles Material</li> <li>• Hitzebeständig bis + 250°C / max. 15 sec.</li> <li>• Handreinigung max. 30–40°C</li> </ul> | <p>Made of silicone with cotton lining</p> <ul style="list-style-type: none"> <li>• For right- and left-handers</li> <li>• Reinforced between thumb and index finger</li> <li>• Waterproof</li> <li>• Flexible material</li> <li>• Heat resistant up to + 250 °C/max.15 sec.</li> <li>• Manual cleaning max. 30–40°C</li> </ul> |
|--|---|

#	↗ mm	→ mm	
<input checked="" type="checkbox"/> 310099	380	150	



DE	BACKHANDSCHUH NEOPREN	
EN	BAKING MITTENS NEOPRENE	
IT	GUANTI DA FORNO IN NEOPRENE	
ES	MANOPLAS NEOPRENE PARA HORNO	

- |  |  |
|--|--|
| <p>Material: Neopren, schwarz</p> <ul style="list-style-type: none"> <li>• Für Rechts- und Linkshänder</li> <li>• Hitzebeständig bis + 250 °C / max. 15 sec.</li> <li>• Rutschfest</li> <li>• Wasserabstoßendes und fleckenresistentes Material</li> <li>• Handreinigung max. 30–40°C</li> </ul> | <p>Made of neoprene, black</p> <ul style="list-style-type: none"> <li>• For right- and left-handers</li> <li>• Heat resistant up to + 250 °C / max. 15 sec.</li> <li>• Non-slip</li> <li>• Water repellent and stain resistant material</li> <li>• Manual cleaning max. 30–40°C</li> </ul> |
|--|--|

#	↗ mm	→ mm	
310085	350	145	



 Weitere Backhandschuhe auf Seite 162 – 165. / Other baking mittens on page 162 – 165.



DE	KARAMELLISIERER / GASTRO-GASBRENNER
EN	PROFESSIONAL CHEF'S BLOWTORCH
IT	CANNELLO
ES	FLAMBEADOR

Nachfüllbarer Gastro-Gasbrenner zum Veredeln von Fleisch, Fisch und anderen kulinarischen Speisen.

- Leistungsstarke Fackelflamme mit rostfreiem Senkkopf für eine gleichmäßig verteilte Flamme (mit Feststellschraube).
- Feines, hochtemperaturbeständiges Drahtgeflecht am Senkkopf. Für ein besonders zartes und schmackhaftes Garergebnis.
- Profi-Gasbrenner mit Selbstentzündung. Hochleistungsdesign mit Metallgasbehälter, ausgestattet mit Kindersicherungsschalter, einstellbarer Flammkontrolle, auszieh-barem Metalldrahtfuß, einfach und sicher zu bedienen.
- Fassungsvermögen / Gasbehälters: 102 ml
- Empfohlener Kraftstoff: Feuerzeugflüssigkeit
- Betriebstemperatur: ca. 1100°C

Refillable professional culinary blowtorch for refining meat, fish and other culinary dishes.

- Powerful torch flame with stainless steel spout for an evenly distributed flame (with locking screw).
- Fine, high-temperature resistant wire mesh at the spout. For a particularly tender and tasty cooking result.
- Professional culinary blowtorch with auto ignition. High-performance design with metal gas container, equipped with child safety switch, adjustable flame control, extendable metal wire at the base for a firm stand, easy and safe to use.
- Capacity of the gas container: 102 ml
- Recommended fuel: butane lighter fuel
- Operating temperature: ca. 1100°C



Flammentemperatur /  
Flame temperature



Flamme einstellbar /  
Adjustable flame



winddicht / windproof



Verbindungsventil /  
Connector valve

#	mm	g
<input checked="" type="checkbox"/> 153093	175 x 75 x 215	440



DE	KARAMELLISIERER / GASBRENNER
EN	BLOWTORCH / CARAMELIZER
IT	CANNELLO
ES	FLAMBEADOR

Für Crème Brulée, Karamellisieren von Speisen aller Art.

- Einfaches und schnelles Befüllen mit Feuerzeuggas
- Gehäuse aus Stahl, Fuß aus Kunststoff
- Einfach zu bedienen
- Mit Kindersicherung
- Verschleißfreie Piezo-Zündung
- Flamme einstellbar
- Flamme bis ca. 1450 °C

For crème brûlée and caramelizing all kinds of food.

- Easy and quick refill with lighter gas
- Body made of steel
- Easy to use
- Child-proof safety lock system
- Self-igniting Piezo Ignition
- Safety adjustable flame
- Flame up to 1450 °C



# 153090



# 153091

#	↑ mm	Ø mm
☑ 153090	165	45
☑ 153091	151	32



DE	KARAMELLISIERER / GASBRENNER-AUFSATZ
EN	CARAMELIZER / BLOWTORCH HEAD
IT	CANNELLO
ES	FLAMBEADOR

Für Crème Brulée, Karamellisieren von Speisen aller Art.

- Einfach zu bedienen
- Mit Kindersicherung
- verschleißfreie Piezo-Zündung
- Flamme einstellbar
- Flamme bis ca. 1450 °C

For crème brûlée and caramelizing all kinds of food.

- Easy to use
- Child-proof safety lock system
- Self-igniting Piezo Ignition
- Safety adjustable flame
- Flame up to 1450 °C



#	↔ mm
☑ 153092	155

**i** direkter Anschluss an handelsübliche Gaskartuschen mit EU-Schraubgewinde „UNEF 7/16“ (Typ D) / Direct connection to standard gas cans with EU screw thread „UNEF 7/16“ (Type D)

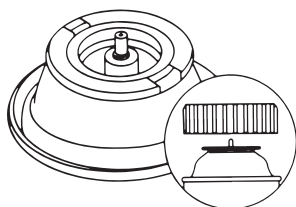

Anwendungsbeispiel / Application example



DE	CREME-FORMEN	<b>SST</b>
EN	YULE LOG MOULDS	
IT	STAMPI PER TRONCHETTO, TONDI	
ES	MOLDES MEDIA CAÑA PARA CREMA REDONDOS	



Material: Edelstahl

Made of stainless steel

**Ausführung: geschlossene Form**  
**Design: rund**

**model: self-contained**  
**design: round**

#	↗ mm	→ mm	↑ mm
193030	500	50	37
193031	500	60	45
193032	500	70	50
193033	500	80	62



DE	DARIOLFORMEN
EN	CREAM TART MOULDS (DARIOL MOULDS)
IT	STAMPI PER DARIOLE
ES	MOLDES PARA DARIOLES

Material: Edelstahl

Made of stainless steel

#	↑ Ø mm	↓ Ø mm	↕	↑ mm
199409	47	35	45	45
199410	54	37	70	50
199411	65	43	100	65
199412	84	60	150	80

DE	DESSERT- / TORTENRINGE	<b>SST</b>
EN	DESSERT- / TART RINGS	
IT	ANELLI PER TORTE E DESSERT	
ES	AROS PARA TARTAS	

Material: Edelstahl

Made of stainless steel



#		↔ mm	↑ mm
155060	Achteck / octagon	Ø: 160	50
155100	Sechseck / hexagon	Ø: 160	50
155110	Sechseck / hexagon	Ø: 180	50
155120	Sechseck / hexagon	Ø: 200	50
155200	Herz / heart	Ø: 180	50
155210	Herz / heart	Ø: 200	50
155220	Herz / heart	Ø: 230	50
155300	Dreieck / triangle	L: 160	50
155310	Dreieck / triangle	L: 180	50
155320	Dreieck / triangle	L: 200	50



# 155100 – 155120

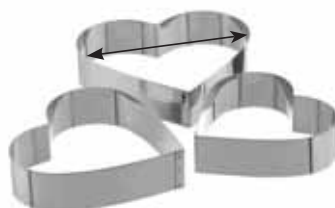

# 155200 – 155220



# 155300 – 155320

DE	DESSERT- / TORTENRINGE	SST
EN	DESSERT- / TART RINGS	
IT	ANELLI PER TORTE E DESSERT	
ES	AROS PARA TARTAS	

Material: Edelstahl

Made of stainless steel

#		↗ mm	↑ mm	↕ mm
155330	Tropfen / tear-drop	160	50	1,2
155331	Tropfen / tear-drop	180	50	1,2
155332	Tropfen / tear-drop	200	50	1,2
155340	Dreieck, gewölbt / triangle, convex	160	50	1,2
155341	Dreieck, gewölbt / triangle, convex	180	50	1,2
155342	Dreieck, gewölbt / triangle, convex	200	50	1,2
155350	Viereck, gewölbt / square, convex	140	50	1,0
155351	Viereck, gewölbt / square, convex	160	50	1,0
155352	Viereck, gewölbt / square, convex	180	50	1,0

# 155330 – 155332



# 155340 – 155342



# 155350 – 155352



DE	DESSERTRING
EN	DESSERT RING
IT	ANELLI PER DOLCI
ES	AROS PARA POSTRES

Material: PS, elfenbein

Made of PS, ivory

• Nicht zum Backen im Ofen geeignet!

• Not suitable for baking in ovens!

#	Ø mm	↑ mm
200950	75	30



**NICHT zum Backen geeignet!**  
**NOT for baking!**

Material: Reinaluminium,

Made of pure aluminium

- Nahtgeschweißt
- Extra stark

- Welded seam
- Extra strong

#	Ø mm	↑ mm	↕ mm
156075	75	30	2
156076	75	40	2



**“MINI”**

Material: Edelstahl

- Materialstärke: 0,8 mm

**“MINI”**

Made of stainless steel

- Thickness: 0,8 mm

#		↔ mm	↑ mm
155450	Rund / round	Ø 70	45
155451	Oval / oval	L: 74 x B: 56	45
155452	Tropfen / drop	L: 77 x B: 54	45
155453	Dreieck / triangle	B: 68	45
155454	Herz / heart	H: 55 x B: 67	45
155455	Sechseck / hexagon	B: 54	45
155456	Quadrat / square	B: 54	45





DE	PENDELSCHÄLER
EN	SWIVEL PEELER
IT	PELAPATATE
ES	PELADOR

Material: Metall  
 • Klinge rostfrei

Made of metal  
 • Blade stainless steel

#	→ mm	↗ mm	
<input checked="" type="checkbox"/> 260868	50	157	



DE	SPARSCHÄLER / QUERSCHÄLER
EN	SPEED PEELER
IT	PELAPATATE
ES	PELADOR

Material: Edelstahl

Made of stainless steel

#	→ mm	↗ mm	
<input checked="" type="checkbox"/> 260869	42	110	



DE	EIERTEILER
EN	EGG SLICER
IT	TAGLIA UOVA
ES	CORTADOR DE HUEVOS

Material: Aluminium  
 • Drähte aus Edelstahl  
 • Schneidet runde und ovale Scheiben

Made of aluminium  
 • Wires made of stainless steel  
 • Cuts round and oval slices

#	↗ mm	→ mm	↑ mm	
199361	135	79	29	



DE	EIERSTÜCKLER
EN	EGG CUTTER
IT	TAGLIA UOVA
ES	CORTADOR DE HUEVOS

Material: Aluminium  
 • Drähte aus Edelstahl  
 • Zum Teilen von hart gekochten Eiern in 6 gleiche Stücke

Made of aluminium  
 • Wires made of stainless steel  
 • For dividing hard boiled eggs into 6 equal pieces

#	↗ mm	→ mm	↑ mm	
199362	181	64	26	

DE	APFELTEILER
EN	APPLE SLICER
IT	TRANCIA SPICCHI PER MELA
ES	CORTADOR DE MANZANAS

Material: Aluminium

- Messer aus Edelstahl
- Zum Teilen in 10 gleiche Stücke und Entfernen des Kerngehäuses

Made of aluminium

- Blades made of stainless steel
- For dividing into 10 equal pieces and removing the core



#	↔ mm
199031	170 x 111 x 43

DE	APFELAUSSTECHE
EN	APPLE CORER
IT	LEVATORSOLI
ES	SACA CORAZÓN DE MANZANAS

Material: Edelstahl, schwarz

- Griff aus PP
- Für schnelles Ausstechen des Kerngehäuses

Made of stainless steel, black

- Handle made of PP
- quick and clean coring



#	↗ mm	Ø mm
<input checked="" type="checkbox"/> 199032	200	16

DE	KNOBLAUCHPRESSE
EN	GARLIC PRESS
IT	SPREMIAGLIO
ES	PRENSA DE AJO

Material: Aluminium

Made of aluminium



#	↔ mm
199364	152 x 25 x 31

DE	OLIVENTSTEINER
EN	OLIVE STONER
IT	SNOCCIOLATORE PER OLIVE
ES	DESHUESADOR DE ACEITUNAS

Material: Aluminium

- Für große und kleine Oliven

Made of aluminium

- For big and small olives



#	↔ mm
199365	169 x 105 x 27



DE	FLASCHEN- UND DOSENÖFFNER
EN	BOTTLE AND CAN OPENER
IT	APRIBOTTIGLIE E APRISCATOLE
ES	ABREBOTELLAS Y ABRELATAS

Material: verchromter Stahl

- Schwarzer Kunststoffgriff
- Leichte Ausführung

Made of chrome-plated steel

- Black handle made of plastic

#	→ mm	⚖️ kg
<input checked="" type="checkbox"/> 151190	200	0,25

DE	DOSENÖFFNER
EN	TIN OPENER
IT	APRISCATOLE
ES	ABRELATAS

- Geeignet für Dosen bis max. 50 cm Höhe
- Passend für Tischmontage mit Verstellerschraube

- Suitable for tins up to max. 50 cm height
- Suitable for table mounting with adjusting screw



SST Cr  
SST

#	↗ mm	→ mm	↑ mm
151170	730	200	50
151175	730	200	50

#	
151171	Ersatzmesser / Spare blade
151172	Ersatzzahnrad / Spare gear wheel



DE	SALATSCHLEUDER
EN	SALAD SPINNER
IT	CENTRIFUGA PER INSALATA
ES	CENTRIFUGADORA PARA ENSALADA

- Material: PP
- Für Salat, Obst und Gemüse
  - Sieb abnehmbar

- Made of PP
- For salad, fruits and vegetables
  - Sieve removable

12 Liter: für 2–3 Salatköpfe  
25 Liter: für 4–5 Salatköpfe

12 liters: for 2–3 heads of lettuce  
25 liters: for 4–5 heads of lettuce

#	↑ mm	Ø mm	l
290160	435	320	12,0
290170	515	420	25,0



DE	TOMATENSCHNEIDEGERÄT	SST
EN	TOMATO SLICER	
IT	AFFETTA POMODORI	
ES	CORTA TOMATE	

- Material: Edelstahl
- Schnittbreite: 5,5 mm
  - Einfache Bedienung
  - Leicht zu reinigen
  - Aus hochwertigem Edelstahl
  - Ergonomischer Hartkunststoff Griff
  - GummifüÙe für eine sichere Standfestigkeit

- Made of stainless steel
- Slices 5,5 mm
  - Simple operation
  - Easy to clean
  - Made of premium stainless steel
  - Ergonomic handle made of plastic rubber feet for secure stability

#	↔ mm
151065	450 x 210 x 210
151066	Ersatzmesser / Spare blades





DE	SAHNESPENDER	<b>SST</b>
EN	CREAM WHIPPERS	
IT	SIFONI PER PANNA	
ES	SIFONES PARA NATA	

Zum Zubereiten von Sahne, Mousses, Desserts, kalten Schäumen und Saucen.

- Inhalt bleibt im Kühlschrank bis zu 14 Tage haltbar
- Inklusive 3 Spritztüllen aus Edelstahl und 1 Reinigungsbürste
- Benötigt Sahnekapseln (N<sub>2</sub>O) (nicht im Lieferumfang enthalten)

For the preparation of whipped cream, mousses, desserts, cold espumas and sauces.

- The contents can be stored in the fridge for up to 14 days
- Includes 3 stainless steel nozzles and 1 cleaning brush
- Requires cream chargers (N<sub>2</sub>O) (not included in the package)



#		
196050		0,5
196060		1,0

DE	SAHNEKAPSELN
EN	CREAM CHARGERS
IT	CARTUCCE (PER SIFONE PER PANNA)
ES	CARGAS PARA SIFÓN

Universalkapseln – für alle Sahnespender geeignet.

- Inhalt / Füllgewicht: 7,6 g (+/-0,4 g) N<sub>2</sub>O – Distickstoffmonoxid.

Universal cream whipper cartridges – suitable for all cream whippers

- 7.6 g (+/- 0.4 g) N<sub>2</sub>O – Nitrous Oxide



#	Menge / amount
196015	10
196020	24
196030	50

Nicht für Luftfracht zugelassen. / Not permitted for transport via airfreight. Innerhalb von 5 Jahren ab dem Produktionsdatum zu verwenden. / Best before 5 years after production date.

DE	KONTAKTGRILL
EN	CONTACT GRILL
IT	GRILL A CONTATTO
ES	GRILL DE CONTACTO

- Edelstahlgehäuse
- Gusseiserne Backplatte
- Einstellbare Plattenhöhe
- Herausnehmbare Auffangschale
- Einstellbare Griffspannung
- Batteriebetriebener und herausnehmbarer akustischer Timer\*
- Stainless steel housing
- Cast iron plate
- Height of plate may be adjusted
- Removable grease collection tray
- Adjustable handle tension
- Battery-operated and removable timer\*, including acoustic signal



# 150900

# 150910

# 150920

# 150930

#	150900 *	150910 *	150920 *	150930 *
	<b>Kontaktgrill – klein gewellt / gewellt</b>	<b>Kontaktgrill – klein gewellt / glatt</b>	<b>Kontaktgrill – gross gewellt / gewellt</b>	<b>Kontaktgrill – gross gewellt / glatt</b>
Grillfläche / grill area mm	240 x 260	240 x 260	290 x 380	290 x 380
↓ mm	420	420	420	420
→ mm	290	290	410	410
↑ mm	245	245	245	245
	2000 W 50 / 60 Hz / 230 Volt	2000 W 50 / 60 Hz / 230 Volt	2400 W 50 / 60 Hz / 230 Volt	2400 W 50 / 60 Hz / 230 Volt
°C	60 bis 300	60 bis 300	60 bis 300	60 bis 300

DE	REINIGUNGSBÜRSTE
EN	CLEANING BRUSH
IT	SPAZZOLA DI PULIZIA
ES	CEPILLO DE LIMPIEZA

- Holzgriff
- Borstenfläche ca. 13 x 2,5 cm
- Wooden handle
- Bristle area approx. 13 x 2.5 cm

#		↗ mm
<input checked="" type="checkbox"/> 120950	Messingdraht / Brass wire	285
<input checked="" type="checkbox"/> 120960	Stahldraht / Steel wire	285





DE	WAFFEL-EISEN MIT DIGITALEM TIMER
EN	WAFFLE MAKERS WITH DIGITAL TIMER
IT	PIASTRE PER WAFFLE CON TIMER DIGITALE
ES	GOFRERAS PROFESIONALES CON TEMPORIZADOR DIGITAL

- Edelstahlgehäuse
  - Mit isoliertem Griff
  - Abnehmbare Fettauffangschale
  - Gusseiserne Backplatte, fest montiert
  - Schnelle und zweiseitige Heizungsversorgung
  - Gleichmäßige Temperaturverteilung
  - Heizung regelbar (60° bis 300°C)
  - Batteriebetriebener und herausnehmbarer akustischer Timer\*
- Stainless steel case
  - With insulated handle
  - Removable grease tray
  - Cast iron baking plate, permanently mounted
  - Fast and two-sided heating supply
  - Even temperature distribution
  - Heating adjustable (60° to 300°C)
  - Battery-operated and removable timer\*, including acoustic signal



# 150730



# 150710



# 150715

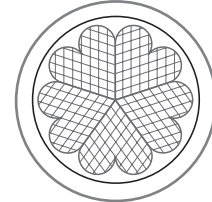
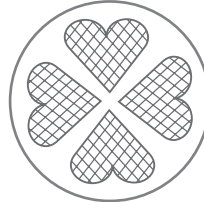
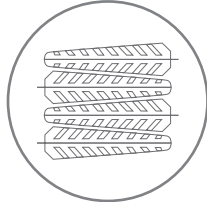

#	150730 *	150710 *	150715 *
	<b>„WAFFEL AM STIEL“ / “ON THE STICK”</b>	<b>„HERZ“ / “HEART”</b>	<b>„HERZ 5“ / “HEART 5”</b>
Waffeln / waffles	4 x	4 x ▲ 100	5 x ▲ 100
mm	55 x 215	↔ mm 165	Ø: 160
↓ mm	420	420	420
→ mm	300	300	300
↑ mm	295	295	295
⚡	1600 W 50 / 60 Hz / 230 Volt	1600 W 50 / 60 Hz / 230 Volt	1600 W 50 / 60 Hz / 230 Volt
°C	60° bis 300°C	60° bis 300°C	60° bis 300°C



DE	WAFFELSTÄBE
EN	WAFFLE-STICKS
IT	STECCHINI PER CIALDE SU STECCO
ES	PALITOS DE GOFRE EN UN PALO

Material: Fichtenholz  
VE: 100 Stück

Made of spruce wood  
100 pieces per unit

#	↔ mm	für/for #
157745	300 x 4 x 4	150730

DE	WAFFEL-EISEN MIT DIGITALEM TIMER
EN	WAFFLE MAKERS WITH DIGITAL TIMER
IT	PIASTRE PER WAFFLE CON TIMER DIGITALE
ES	GOFRERAS PROFESIONALES CON TEMPORIZADOR DIGITAL

- Edelstahlgehäuse
  - Mit isoliertem Griff
  - Abnehmbare Fettauffangschale
  - Gusseiserne Backplatte, fest montiert
  - Schnelle und zweiseitige Heizungsversorgung
  - Gleichmäßige Temperaturverteilung
  - Heizung regelbar (60° bis 300°C)
  - Batteriebetriebener und herausnehmbarer akustischer Timer\*
- Stainless steel case
  - With insulated handle
  - Removable grease tray
  - Cast iron baking plate, permanently mounted
  - Fast and two-sided heating supply
  - Even temperature distribution
  - Heating adjustable (60° to 300°C)
  - Battery-operated and removable timer\*, including acoustic signal



# 150700

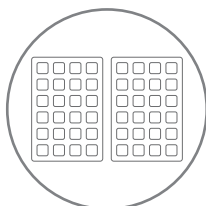

# 150720

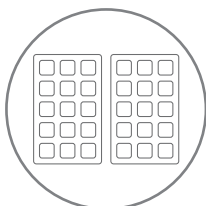

# 150790

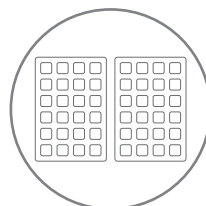

150700 *	150720 *	150790 *	#
<b>„QUADRO“</b>	<b>„BELGIEN“ / „BELGIUM“</b>	<b>„180° – drehbar“ „QUADRO“ / „180° – turnable“ „QUADRO“</b>	
2 x 100 x 185	2 x 100 x 185	2 x 110 x 185	Waffeln / waffles mm
420	420	540	↓ mm
300	300	305	→ mm
295	295	300	↑ mm
1600 W 50 / 60 Hz / 230 Volt	1600 W 50 / 60 Hz / 230 Volt	1800 W 50 / 60 Hz / 230 Volt	
60° bis 300°C	60° bis 300°C	60° bis 300°C	°C

DE	HEBEL-DOSIERSPENDER / TEIGDOSIERER – STANDGERÄT
EN	DOSING DISPENSER – TABLE STANDING UNIT
IT	DOSATORE A LEVA DA BANCO
ES	DOSIFICADOR DE MESA CON PALANCA

Speziell für Waffel- und Crêpes-Eisen

- Material: Edelstahl
- Hebelbedienung
- Höhenverstellbar
- Auslauf schwenkbar
- Dosierung einstellbar / ± 50 ml

Especially for waffle and crepe makers

- Made of stainless steel
- Lever operation
- Height adjustable
- Swivel spout
- Dosing adjustable / ± 50 ml

#	↔ mm	↑ mm	⚙
152475	450 x 450 x 1000	4,0	

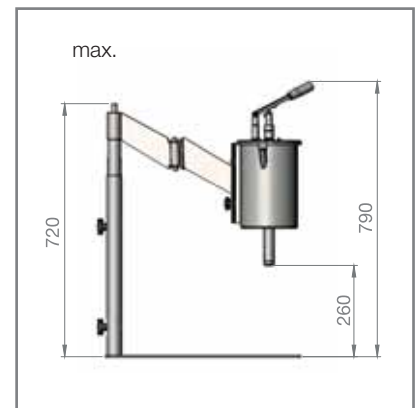
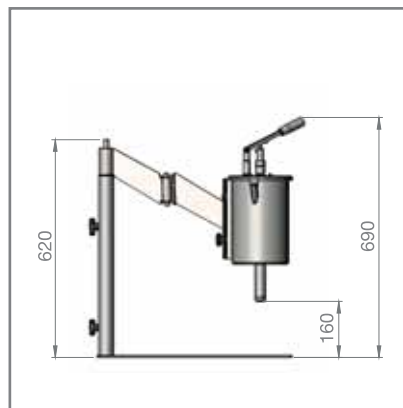
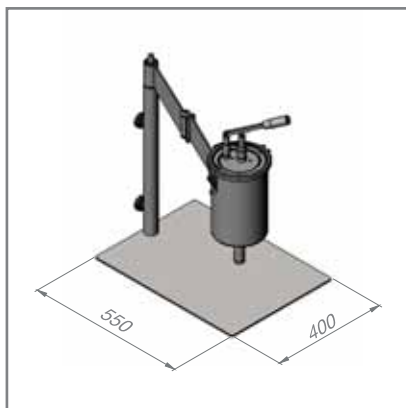

DE	TEIGDOSIERER
EN	DOUGH DISPENSER
IT	DOSATORE PER IMPASTI
ES	DOSIFICADOR PARA LA PASTA

Zum manuellen Dosieren von flüssigem Teig

- Behälter aus Edelstahl
- Inklusive Ständer

For manual dough portioning

- Body made of stainless steel
- Including stand

#	Ø mm	↑ mm	⚙
152975	167	395	2,0

DE	CREPES-EISEN
EN	CREPE MAKER
IT	CREPIERA
ES	CREPERA

- |  |   |
|--|---|
| <ul style="list-style-type: none"> <li>• Platten-Durchmesser: 40 cm</li> <li>• Teflon-Beschichtung</li> <li>• Außengehäuse Edelstahl</li> <li>• Temperatur stufenlos regelbar (140°C – 300°C)</li> <li>• Geringer Energieverbrauch</li> <li>• Inklusive Spatula und Verteiler</li> </ul> | <ul style="list-style-type: none"> <li>• Plate diameter: 40 cm</li> <li>• Teflon-coated</li> <li>• Outer casing made of stainless steel</li> <li>• Temperature continuously adjustable (140°C – 300°C)</li> <li>• Low energy consumption</li> <li>• Including spatula and spreader</li> </ul> |
|--|---|

#	150600	150610
Ø mm	400	400
↓ mm	400	445
→ mm	400	430
↑ mm	125	175
	2700 W 50 / 60 Hz 230 V	2700 W 50 / 60 Hz 230 V
°C	140 – 300	140 – 300

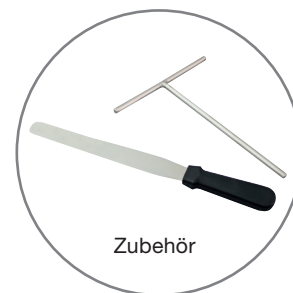

Zubehör



# 150600



# 150610

DE	CREPES-SCHIEBER
EN	CREPE SPREADERS
IT	STENDI CREPES
ES	RASTRILLOS DE CREPES

#	↔ mm	
157760	200 x 145	Holz / Wood
157770	180 x 180	Edelstahl / Stainless steel



14

DE	CREPES-WENDER
EN	CREPE SPATULA
IT	SPATOLA PER CREPE
ES	ESPÁTULA CREPE

#	↗ mm	→ mm
262636	360	34





DE	FRISCHHALTEFOLIE
EN	CLINGFILMS
IT	PELLICOLE PER ALIMENTI
ES	FILM ESTIRABLE

Material: lebensmittelechte Haftfolie (PE)  
 • Hervorragende Hafteigenschaften  
 • Atmungsaktiv geeignet auch zum Verpacken fetthaltiger Produkte

High quality clingfilm (PE)  
 • Excellent adhesive strength  
 • Breathable, usable also for greasy products

**“UNIFOL” - PERFORIERT**  
**Materialstärke: 12 µ**

**“UNIFOL” - PERFORATED**  
**Thickness: 12 µ**

#	Perforation / perforation mm	↗ m
131030	250 x 250	500
131040	300 x 300	500
131050	350 x 350	500
131060	400 x 400	500
131070	450 x 450	500
131080	600 x 600	350



**“UNIFOL” - ENDLOS**  
**Materialstärke: 12 µ**

**“UNIFOL” - ENDLESS**  
**Thickness: 12 µ**

#	→ mm	↗ m
132040	300	300
132070	450	300
132090	600	300



**“EUROFOL” - ENDLOS**  
**Materialstärke: 10 µ**

**“EUROFOL” - ENDLESS**  
**Thickness: 10 µ**

#	→ mm	↗ m
131800	290	300
131801	440	300
131802	590	300



DE	FOLIEN-ABREISSVORRICHTUNG
EN	CLINGFILM TEAR-OFF-DISPENSERS
IT	PORTA PELLICOLE
ES	SOPORTE PARA FILM ESTIRABLE

Aus Metall, robuste Ausführung  
 • Für Großrollen  
 • Mit Schneidekopf

Made of metal  
 • For jumbo-rolls  
 • With cutter

#	für/for  mm
158310	400
158320	500
158330	850

DE	FOLIEN-ABREISSVORRICHTUNG
EN	CLINGFILM TEAR-OFF-DISPENSERS
IT	PORTA PELLICOLE
ES	SOPORTE PARA FILM ESTIRABLE

Aus Metall, **stabile Ausführung**

- Für perforierte Folien, max. 11 cm Ø
- Wandmontage oder als Tischgerät verwendbar, Breite ca. 20 cm

Made of metal, **strong execution**

- Only for perforated rolls, max. 11 cm Ø
- Wall fastening and tabletop unit, width approx. 20 cm

#		
158010	einfach / single	
158020	doppelt / double	



Aus Metall, **leichte Ausführung**

- Mit Säge, für Endlosfolien Ø max. 80 mm

Made of metal, **light execution**

- With saw, for endless rolls Ø max. 80 mm

#	für/for $\left[ \leftarrow \rightarrow \right]$ mm	
158140	300	einfach / single
158150	450	einfach / single



Aus Metall, **stabile Ausführung mit Gegenstrebe**

- Mit Säge, für Endlosfolien Ø max. 80 mm

Made of metal, **strong execution with brace**

- With saw, for endless rolls Ø max. 80 mm

#	für/for $\left[ \leftarrow \rightarrow \right]$ mm	
158110	300	einfach / single
158120	450	einfach / single
158130	600	einfach / single



Aus Metall, **stabile Ausführung mit Gegenstrebe**

- Mit Säge, für Endlosfolien Ø max. 80 mm

Made of metal, **strong execution**

- With saw, for endless rolls Ø max. 80 mm

#	für/for $\left[ \leftarrow \rightarrow \right]$ mm	
158210	300	doppelt / double
158220	450	doppelt / double



**Material: Edelstahl, stabile Ausführung mit Gegenstrebe**

- Mit Säge, für Endlosfolien Ø max. 80 mm

**Made of stainless steel, strong execution**

- With saw, for endless rolls Ø max. 80 mm

#	für/for $\left[ \leftarrow \rightarrow \right]$ mm	
158410	300	einfach / single
158420	450	einfach / single





# 200670

**NEW**



DE	PIZZASCHAUFEL	SST	PA	+300 °C				
EN	PIZZA PEEL							
IT	PALA PER PIZZA							
ES	ESPÁTULA PARA PIZZA							

- Mit Edelstahlstiel
- Mit schwarzen Kunststoffgriffen
- Mittlerer Griff bewegbar
- With stainless handle
- With black handles
- Lower handle movable

#				
200670	Ø 240	1200	1440	



DE	PIZZASCHAUFEL	ALU	+350 °C			
EN	PIZZA PEEL					
IT	PALA PER PIZZA					
ES	ESPÁTULA PARA PIZZA					

- Selbstmontage
- Mit schwarzem Aluminiumstiel
- Self-assembly
- With black aluminium handle

#					
200650	370 x 360	1100	1485	✓	
200651	370 x 360	1500	1885	✓	
200652	425 x 400	1100	1525	✓	
200653	425 x 400	1500	1925	✓	
200660	385 x 360	1100	1485	-	
200661	385 x 360	1500	1885	-	
200662	425 x 400	1100	1525	-	
200663	425 x 400	1500	1925	-	



#200650



#200660

DE	PIZZASCHAUFEL				
EN	PIZZA PEEL	ALU	WOOD	+300 °C	
IT	PALA PER PIZZA				
ES	ESPÁTULA PARA PIZZA				

- Mit Holzstiel
- With wooden handle

#				
200640	360 x 305	555	910	
200641	455 x 405	860	1320	



DE	PIZZASCHAUFEL				
EN	PIZZA PEEL	ALU	+300 °C		
IT	PALA PER PIZZA				
ES	ESPÁTULA PARA PIZZA				

- Mit Aluminiumstiel
- With aluminium handle

#				
200642	280 x 230	635	915	
200643	355 x 305	970	1325	



DE	PIZZASCHAUFEL				
EN	PIZZA PEEL	ALU	+300 °C		
IT	PALA PER PIZZA				
ES	ESPÁTULA PARA PIZZA				

- Mit Aluminiumstiel
- With aluminium handle

#				
200647	230 x 180	260	490	





DE	PIZZABLECHE	
EN	PIZZA TRAYS	
IT	TEGLIE PER PIZZA IN FERRO BLU	
ES	BANDEJAS PARA PIZZA DE HIERRO AZUL	

Material: Blaublech

- Nach Benutzung mit Küchenpapier ausreiben, gut abtrocknen, dann innen und außen mit Speiseöl einreiben
- Vor Erstgebrauch bei ca. 200°C 10 min. einbrennen und einölen
- Temperaturbeständig bis + 400°C

Made of blue steel

- After use clean with kitchen paper, dry well, then wipe with cooking oil inside and outside
- Before first use: bake at approx. 200°C for 10 min. and then oil
- Heat resistant up to + 400°C

**Materialstärke: 0,8 mm**

**Thickness: 0.8 mm**



#997200

**NEW**

#	↑ Ø mm	↓ Ø mm	↑ mm
997140	140	125	25
997160	160	145	25
997180	180	165	25
997200	200	180	25
997220	220	200	25
997240	240	220	25
997260	260	240	25
997280	280	260	25
997300	300	280	25
997320	320	300	25
997340	340	320	25
997360	360	340	25
997400	400	380	25
997450	450	425	35
997500	500	475	35



**GN 1/1**

**Materialstärke: 0,8 mm**

**Thickness: 0.8 mm**

#	→ mm	↗ mm	↑ mm
997900	400	600	25
997901	340	450	25
997902	350	500	25
997903	300	400	25
997904	325	530	25

DE	PIZZABLECHE
EN	PIZZA MOULDS
IT	TEGLIE PER PIZZA IN ALLUMINIO
ES	MOLDES Y BANDEJAS PARA PIZZA DE ALUMINIO

- Lochung: 3 mm
- Perforation: 3 mm

#	↑ Ø mm	↓ Ø mm	↑ mm
997630	180	160	25
997631	200	180	25
997632	220	200	25
997633	240	220	25
997634	260	240	25
997635	280	260	25
997636	300	280	25
997637	320	300	25
997638	340	320	25
997639	360	340	25
997640	400	385	25
997660	380	360	25
997641	420	400	25
997642	520	500	25



DE	PIZZAGITTER / PIZZA-SCREEN
EN	PIZZA SCREENS
IT	RETINE PER PIZZA
ES	REJAS PARA PIZZA

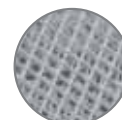

#	Ø mm	⊞ mm
997620	250	6
997621	280	6
997622	300	6
997623	330	6
997624	355	6
997625	405	6



DE	STÄNDER FÜR KUCHEN- UND PIZZABLECHE
EN	SUPPORT FOR CAKE- AND PIZZA MOULDS
IT	SUPPORTO PER TEGLIE PIZZA E TORTIERE
ES	SOPORTE PARA MOLDES DE PIZZA Y PASTELERIA



- 14 Auflagen von Blechen und Pfannen
- Auflage: 210 x 240 mm
- Abstand: 40 mm
- **Auch zur Wandmontage geeignet**
- 14 shelves
- Shelf dimension: 210 x 240 mm
- Distance: 40 mm
- **Also suitable for wall mounting**

#	↔ mm
154813	310 x 330 x 770





#202172

DE	PIZZABALLENBEHÄLTER		
EN	PIZZA DOUGH CONTAINER	HDPE	-40 +75 °C
IT	CONTENITORE PER PASTA PIZZA		
ES	CONTENEDOR PARA BALAS DE PIZZA		

#	→□← mm	↔ mm	↑ mm
202170	600 x 400 x 75	565 x 365 x 70	14,0
202172	600 x 400 x 95	565 x 365 x 90	18,0
202173	600 x 400 x 130	565 x 365 x 120	24,0



DE	DECKEL		
EN	LID	PP	-40 +75 °C
IT	COPERCHIO		
ES	TAPA		

- Passend für alle Pizzaballenbehälter 60x40
- Suitable for all pizza dough containers 60x40

#	↗ mm	→ mm	↑ mm
202171	600	400	40

**i** Deckel ist nicht beidseitig verwendbar / Lid can't be used on both sides

**NEW**



#202175

DE	PIZZABALLENBEHÄLTER		
EN	PIZZA DOUGH CONTAINER	PP	-20 +80 °C
IT	CONTENITORE PER PASTA PIZZA		
ES	CONTENEDOR PARA BALAS DE PIZZA		

#	→□← mm	↔ mm	↑ mm
202174	400 x 300 x 75	360 x 260 x 73	7,0
202175	400 x 300 x 100	360 x 260 x 98	10,0

**NEW**



DE	DECKEL		
EN	LID	PP	-20 +80 °C
IT	COPERCHIO		
ES	TAPA		

- Passend für alle Pizzaballenbehälter 40x30
- Suitable for all pizza dough containers 40x30

#	↗ mm	→ mm	↑ mm
202176	400	300	17

**i** Deckel ist nicht beidseitig verwendbar / Lid can't be used on both sides

DE	PIZZATEIG-DOCKER
EN	PIZZA DOUGH DOCKERS
IT	RULLI BUCASFOGLIA
ES	RODILLOS PARA PINCHAR HOJALDRE

Material: Edelstahl / Aluminium  
 • Mit ergonomischem Kunststoffgriff

Made of stainless steel / aluminium  
 • With ergonomic plastic handle

#	→ mm	
154104	120 mm	



Material: Kunststoff (POM), elfenbein  
 • Mit verstärktem Kunststoffgriff

Made of plastic (POM), ivory  
 • With reinforced plastic handle

#	→ mm	
<input checked="" type="checkbox"/> 200001	65	
<input checked="" type="checkbox"/> 200002	120	



Material: Kunststoff (POM), elfenbein  
 • Ergonomischer Griff  
 • Halterung aus Metall

Made of plastic (POM), ivory  
 • Ergonomic handle  
 • Mounting made of metal

#	→ mm	
200182	270	

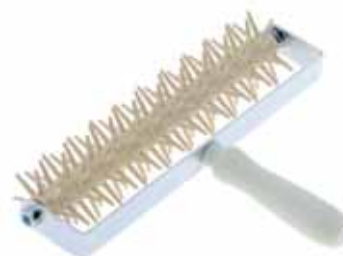

DE	PIZZA-OFENBÜRSTE
EN	PIZZA OVEN BRUSH
IT	SPAZZOLA PER FORNI PER PIZZA
ES	CEPILLO PARA HORNO DE PIZZA

Borsten aus Carbonstahl  
 • Mit Stiel

Bristles made of carbon steel  
 • With handle

#	←→ mm	
200644	1040	Besen mit Stiel / Broom with handle
200648	250	Besen / Broom
200649	1000	Ersatzstiel / Spare handle



#200644



DE	PIZZABLECH-ZANGE	
EN	PIZZASHEET TONG	
IT	PINZA PER TEGLIE	SST
ES	PINZA PARA BANDEJAS DE PIZZA	

#	↗ mm	
200646	200	





©stock.adobe.com

DE	HANDSCHIESSER	 
EN	OVEN PEELS	
IT	PALE PER FORNO	
ES	PALAS PARA HORNEAR	

Material: Buchenholz

Made of beech wood



#	↗ mm	→ mm	
203411	500	120	
203412	500	140	
203413	500	160	
203414	500	180	
203415	950	180	
203416	950	200	
203417*	1150	180	
203418*	1150	200	



DE	AUSKÜHLPLATTEN FÜR PIZZA / FLAMMKUCHEN	SST
EN	COOLING PLATES FOR PIZZA	
IT	PIASTRE DI RAFFREDDAMENTO PER PIZZA	
ES	PLACAS DE ENFRIAMIENTO DE PIZZA	

• Praktisches Display mit Luftlöchern zum Auskühlen

• Practical display with air holes for cooling hot pizza

#	Ø mm	↑ mm	
159700	320	50	
159701	320	100	
159702	320	150	

DE	TEIG- UND PIZZASCHNEIDER	<b>SST</b>
EN	DOUGH AND PIZZA CUTTERS	
IT	ROTELLE TAGLAPASTA E TAGLIAPIZZA	
ES	RULETAS CORTAMASA-CORTAPIZZA	

- Kunststoffgriff
- Handschutz und Aufhängeöse
- Sehr robuste Ausführung
- Plastic handle
- With hand protection
- Very strong quality

#		Ø mm
<input checked="" type="checkbox"/> 200005	einfach, glatt / single, plain	55
<input checked="" type="checkbox"/> 200006	einfach gewellt / single serrated	55
<input checked="" type="checkbox"/> 200007	doppelt glatt und gewellt / double, plain and serrated	55
<input checked="" type="checkbox"/> 200115	einfach, glatt / single, plain	100



# 200005



# 200006



# 200007



# 200115

DE	TEIG- UND PIZZASCHNEIDER	<b>SST</b>
EN	DOUGH AND PIZZA CUTTERS	
IT	ROTELLE TAGLAPASTA E TAGLIAPIZZA	
ES	RULETAS CORTAMASA-CORTAPIZZA	

- Ergonomischem Griff aus schwarzem PP
- Ca. 255 mm lang
- Ergonomic handle made of black PP
- Ca. 255 mm length

#		Ø mm
200116	einfach, glatt / single, plain	125



DE	PIZZA-WIEGEMESSER / PIZZATEILER	<b>SST</b>
EN	PIZZA CHOPPER	
IT	TRONCHI TAGLIAPIZZA	
ES	CORTANTE PARA PIZZA	

- Materialstärke: 1,0 mm
- Runder Griff
- Thickness 1.0 mm
- Round handle

#	→ mm	↑ mm
200625	304	95
200626	348	93
200627	400	97



# 200625

# TOP-BOX PIZZA

- Speziell für heiße Pizzen
- Auch geeignet für frische Lebensmittel, Getränke, Kuchen
- Inklusive Deckel
- Ergonomisches Griffdesign
- Especially for hot pizzas
- Also suitable for fresh food, drinks, cakes
- Including lid
- Ergonomic handle design



\* mit Noppen für bessere Luftzirkulation /  
\* with knobs for improved air circulation



DE	TRANSPORTBOX TOP PIZZA
EN	TRANSPORT BOX TOP PIZZA
IT	TRANSPORTINO TOP PIZZA
ES	CAJA DE TRANSPORTE TOP PIZZA

#	→□← mm	↔ mm	↑↓
650165	410 x 410 x 165	350 x 350 x 100	12,0
650240	410 x 410 x 240	350 x 350 x 175	21,0
650330 *	410 x 410 x 330	350 x 350 x 265	32,0
650395	410 x 410 x 395	350 x 350 x 330	40,0

DE	ERSATZDECKEL	
EN	SPARE LID	EPP PIZZA S
IT	COPERCHIO DI RICAMBIO	
ES	TAPA DE RECAMBIO	

- Passend für alle TOP PIZZA S
- Suitable for all TOP PIZZA S

#	→□← mm
650990	410 x 410 x 35



DE	TRANSPORTBOX TOP PIZZA
EN	TRANSPORT BOX TOP PIZZA
IT	TRANSPORTINO TOP PIZZA
ES	CAJA DE TRANSPORTE TOP PIZZA

#	→□← mm	↔ mm	↑ mm
651165	480 x 480 x 182	420 x 420 x 117	21,0
651260 *	480 x 480 x 265	420 x 420 x 200	35,0



DE	ERSATZDECKEL	EPP	PIZZA	L
EN	SPARE LID			
IT	COPERCHIO DI RICAMBIO			
ES	TAPA DE RECAMBIO			

- Passend für alle TOP PIZZA L
- Suitable for all TOP PIZZA L

#	→□← mm
651990	480 x 480 x 35

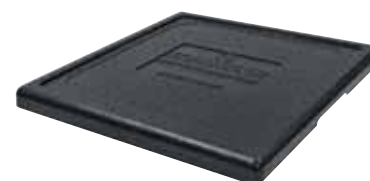

DE	TRANSPORTBOX TOP PIZZA
EN	TRANSPORT BOX TOP PIZZA
IT	TRANSPORTINO TOP PIZZA
ES	CAJA DE TRANSPORTE TOP PIZZA

#	→□← mm	↔ mm	↑ mm
652280	595 x 595 x 182	535 x 535 x 115	33,0



DE	ERSATZDECKEL	EPP	PIZZA	XL
EN	SPARE LID			
IT	COPERCHIO DI RICAMBIO			
ES	TAPA DE RECAMBIO			

- Passend für TOP PIZZA XL
- Suitable for TOP PIZZA XL

#	→□← mm
652990	595 x 595 x 35



DE	TRANSPORTHILFE	ALU	PIZZA	S
EN	TRANSPORT ASSISTANCE			
IT	AIUTO AL TRASPORTO			
ES	AIUTO AL TRASPORTO			

- Passend für # 650240, 650330, 650395
- Geeignet für Pizza & Torte
- Mit Bodenlochung: 3 mm
- Suitable for # 650240, 650330, 650395
- Suitable for pizza & cake
- With perforated base: 3 mm

#	↗ mm	→ mm	↑ mm
690030	340	340	150



- ▶ Klingen aus erstklassigem Chrom-Molybdän-Stahl, Messerhärte 52 HRC.
- ▶ ergonomische Schalen-Griffe (POM) mit 2 oder 3 Edelstahlrieten

- ▶ raw blades made of first class chrome-molybdenum steel, knife hardness 52 HRC.
- ▶ ergonomically shaped handles made of POM with 2 or 3 stainless steel rivets



DE	BÄCKERMESSER
EN	BAKER'S KNIVES
IT	COLTELLI PASTICCERIA
ES	CUCHILLOS PARA PASTELERÍA



#		↗ mm*	→ mm*	
<input checked="" type="checkbox"/> 264036	glatte Schneide / straight edge	360	33	
<input checked="" type="checkbox"/> 264131	feine Säge / fine saw edge	310	33	
<input checked="" type="checkbox"/> 264136	feine Säge / fine saw edge	360	33	
<input checked="" type="checkbox"/> 264226	Welle / wave	260	33	
<input checked="" type="checkbox"/> 264231	Welle / wave	310	33	
<input checked="" type="checkbox"/> 264236	Welle / wave	360	33	

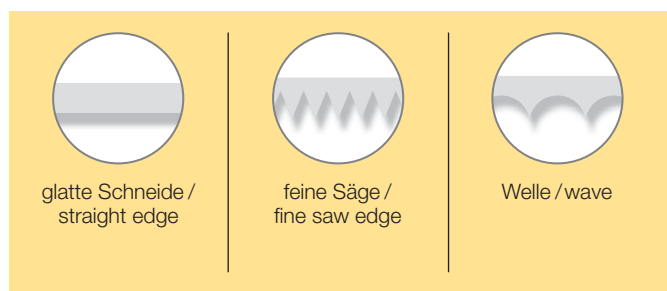

↗ mm\*: Klingenlänge / blade length → mm\*: Klingebreite / blade width

DE	KUCHENBLECHMESSER
EN	CAKE KNIFE
IT	COLTELLI DA TORTA E PASTICCERIA
ES	CUCHILLOS PARA TARTA Y PASTELERÍA

#		↗ mm*	→ mm*	
<input checked="" type="checkbox"/> 264931	Welle / wave	310	33	



DE	UNIVERSALMESSER
EN	UNIVERSAL KNIFE
IT	COLTELLI UNIVERSALE
ES	CUCHILLOS UNIVERSÁL

#			↗ mm*	
<input checked="" type="checkbox"/> 265326	Welle / wave		260	



DE	KONDITIONMESSER
EN	CONFECTIONER'S KNIVES
IT	COLTELLI DA TORTA E PASTICCERIA
ES	CUCHILLOS PARA TARTA Y PASTELERÍA

#		↗ mm*	→ mm*	
<input checked="" type="checkbox"/> 265426	glatte Schneide / straight edge	260	24	
<input checked="" type="checkbox"/> 265431	glatte Schneide / straight edge	310	24	
<input checked="" type="checkbox"/> 265526	feine Säge / fine saw edge	260	24	
<input checked="" type="checkbox"/> 265531	feine Säge / fine saw edge	310	24	
<input checked="" type="checkbox"/> 265536	feine Säge / fine saw edge	360	24	
<input checked="" type="checkbox"/> 265626	Welle / wave	260	24	
<input checked="" type="checkbox"/> 265631	Welle / wave	310	24	
<input checked="" type="checkbox"/> 265636	Welle / wave	360	24	



DE	KÜCHENMESSER
EN	KITCHEN KNIFE
IT	COLTELLO DA CUCINA
ES	CUCHILLO DE COCINA

#			↗ mm*	
<input checked="" type="checkbox"/> 265826	Welle / wave		260	



DE	BROTMESSER
EN	BREAD KNIFE
IT	COLTELLI DA PANE
ES	CUCHILLOS PARA PAN



#		↗ mm*	
<input checked="" type="checkbox"/> 265921	Welle / wave	210	
<input checked="" type="checkbox"/> 265926	Welle / wave	260	

DE	PALETTE MIT WELLENSCHLIFF
EN	PALETTE KNIFE WITH SCALLOPED EDGE
IT	SPATOLA SMUSSATA A LAMA SMERLATA
ES	ESPÁTULA SIN FILO



#		↗ mm*	→ mm*	
<input checked="" type="checkbox"/> 262640	Welle / wave	310	34	

DE	KUCHENBLECHMESSER
EN	CAKE KNIVES
IT	COLTELLI DA TORTA E PASTICCERIA
ES	CUCHILLOS PARA TARTA Y PASTELERÍA



#		↗ mm*	
<input checked="" type="checkbox"/> 262518	Welle / wave	180	
<input checked="" type="checkbox"/> 262522	Welle / wave	220	

DE	TORTENMESSER
EN	PIE KNIVES
IT	COLTELLI DA TORTA
ES	CUCHILLOS PARA TARTA



#		↗ mm*	
<input checked="" type="checkbox"/> 262600	glatte Schneide, feine Säge / straight edge, fine saw edge	160	
<input checked="" type="checkbox"/> 262601	Wellenschliff, glatte Schneide / wavy edge, straight edge	160	
<input checked="" type="checkbox"/> 262602	Wellenschliff, feine Säge / wavy edge, fine saw edge	160	

 glatte Schneide / straight edge	 feine Säge / fine saw edge	 Welle / wave	 feine Säge, glatte Schneide / fine saw edge and straight edge	 Wellenschliff, glatte Schneide / wavy edge and straight edge	 Wellenschliff, feine Säge / wavy edge and fine saw edge
-------------------------------------	--------------------------------	------------------	---	--	---

↗ mm\*: Klingenlänge / blade length → mm\*: Klingenbreite / blade width

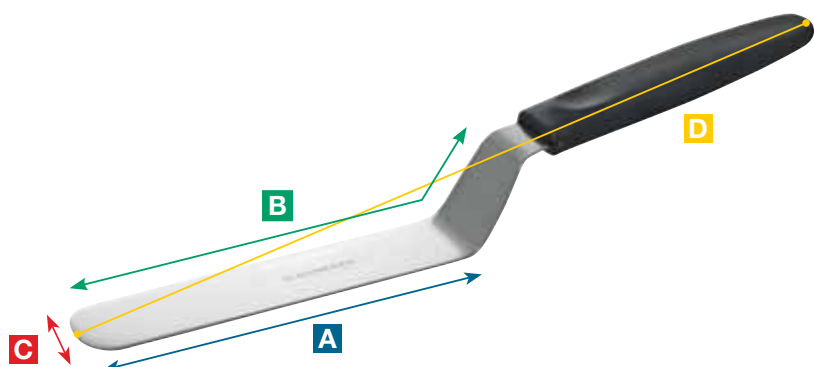

- A** Streichfläche / working surface
- B** Länge der Klinge / length of blade
- C** Breite der Klinge / width of blade
- D** Gesamtlänge / total length

DE	BACK- UND GLASURPALETTEN
EN	PALETTE KNIVES
IT	SPATOLE SMUSSATE
ES	ESPÁTULAS SIN FILO

#	A (mm)	C (mm)	D (mm)
<input checked="" type="checkbox"/> 262612	120	18	230
<input checked="" type="checkbox"/> 262616	160	34	290
<input checked="" type="checkbox"/> 262621	210	34	345
<input checked="" type="checkbox"/> 262626	260	34	385
<input checked="" type="checkbox"/> 262631	310	34	445
<input checked="" type="checkbox"/> 262636	360	34	485



DE	TORTENRINGPALETTE
EN	TARTRING SPATULA
IT	SPATOLA PER ANELLO DA TORTA
ES	ESPÁTULA PARA ARO DE TARTAS

#	A (mm)	B (mm)	C (mm)	D (mm)
<input checked="" type="checkbox"/> 262825	180	250	34	335



DE	WINKELPALETTEN
EN	ANGULAR SPATULAS
IT	SPATOLE ANGOLARI
ES	ESPÁTULAS CURVADAS

#	A (mm)	B (mm)	C (mm)	D (mm)
<input checked="" type="checkbox"/> 262712	90	150	18	230
<input checked="" type="checkbox"/> 262721	180	210	34	345
<input checked="" type="checkbox"/> 262726	230	260	34	405
<input checked="" type="checkbox"/> 262731	280	310	34	455
<input checked="" type="checkbox"/> 262736	325	360	34	500



Aluminium				
227214	175	230	35	310

# 227214

- ▶ Klinsen aus erstklassigem Chrom-Molybdän-Stahl, Vakuum-gehärtet, lange Schnitthaltigkeit.
- ▶ ergonomischer und rutschsicherer Griff aus Kunststoff.

- ▶ raw blades made of first class chrome-molybdenum steel, vacuum hardened, grinding in two steps.
- ▶ ergonomically shaped and slip-proof handle made of plastic.



DE	KONDITIONMESSER
EN	CONFECTIONER'S KNIVES
IT	COLTELLI PER PASTICCIERE
ES	CUCHILLOS PARA PASTELERO



#		↗ mm*	
<input checked="" type="checkbox"/>	260630	glatte Schneide / straight edge	300
<input checked="" type="checkbox"/>	260631	feine Säge / fine saw edge	300
<input checked="" type="checkbox"/>	260632	Wellenschliff / wavy edge	300
<input checked="" type="checkbox"/>	260640	glatte Schneide / straight edge	360
<input checked="" type="checkbox"/>	260641	feine Säge / fine saw edge	360
<input checked="" type="checkbox"/>	260642	Wellenschliff / wavy edge	360

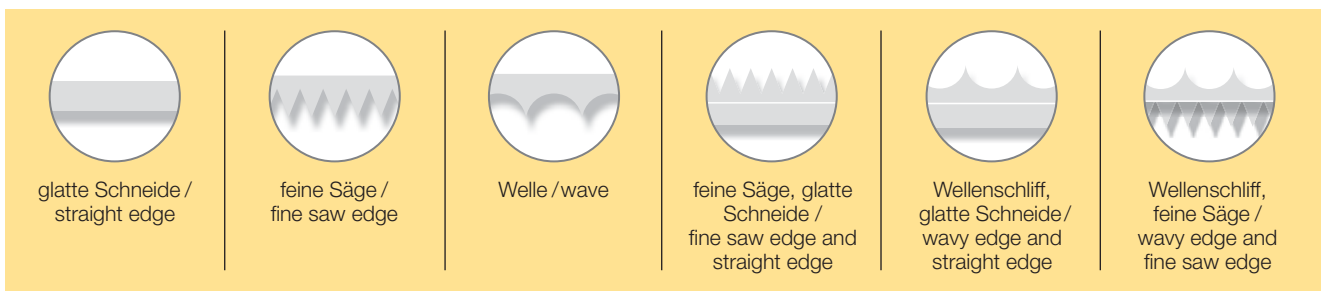

↗ mm\*: Klingenlänge / blade length → mm\*: Klingenbreite / blade width

DE	BÄCKERMESSER
EN	BAKER'S KNIVES
IT	COLTELLI PER PANETTIERE
ES	CUCHILLOS PARA PANADERIA

#		↗ mm*
<input checked="" type="checkbox"/> 260561	Welle / wave	250
<input checked="" type="checkbox"/> 260571	Welle / wave	310



DE	TORTENMESSER
EN	PIE KNIVES
IT	COLTELLI PER TORTE
ES	CUCHILLOS PARA TARTA

#		↗ mm*
<input checked="" type="checkbox"/> 260610	feine Säge, glatte Schneide / fine saw edge, straight edge	160
<input checked="" type="checkbox"/> 260611	glatte Schneide, Wellenschliff / straight edge, wavy edge	160
<input checked="" type="checkbox"/> 260612	feine Säge, Wellenschliff / fine saw edge, wavy edge	160



DE	KUCHEN- UND KÜCHENMESSER
EN	CAKE AND PASTRY KNIVES
IT	COLTELLI PER TORTE E PASTICCERIA
ES	CUCHILLOS PARA TARTA Y PASTERÍA

#		↗ mm*
<input checked="" type="checkbox"/> 260650	glatte Schneide / straight edge	310
<input checked="" type="checkbox"/> 260651	feine Säge / fine saw edge	310
<input checked="" type="checkbox"/> 260652	Welle / wave	310



DE	BACKBLECHMESSER, ABGEWINKELT
EN	ANGULAR KNIVES, WAVY EDGE
IT	COLTELLI ANGOLATI PER TEGLIE
ES	CUCHILLOS ANGULADOS PARA BANDEJA DE HORNO

#		↗ mm*
<input checked="" type="checkbox"/> 260730	Welle / wave	200





DE	BROTMESSER
EN	BREAD KNIVES
IT	COLTELLI DA PANE
ES	CUCHILLOS PARA PAN

#		↗ mm*
<input checked="" type="checkbox"/> 260582	Welle / wave	210
<input checked="" type="checkbox"/> 260592	Welle / wave	240
<input checked="" type="checkbox"/> 260600	Welle – Brotmesser spezial, abgewinkelter Griff / wave – Bread knife special, angled handle	180



DE	BROT- UND AUFSCHNITTMESSER MIT ABSTANDSHALTER
EN	BREAD AND SLICING KNIVES WITH SPACER
IT	COLTELLI DA PANE CON DISTANZIATORE
ES	CUCHILLOS PARA PAN CON GUÍA DE CORTE

#		↗ mm*
<input checked="" type="checkbox"/> 260740	Welle / wave	210
<input checked="" type="checkbox"/> 260742	Welle, abgerundete Klinge / wave, rounded blade	250



↗ mm\*: Klingenlänge / blade length → mm\*: Klingenbreite / blade width

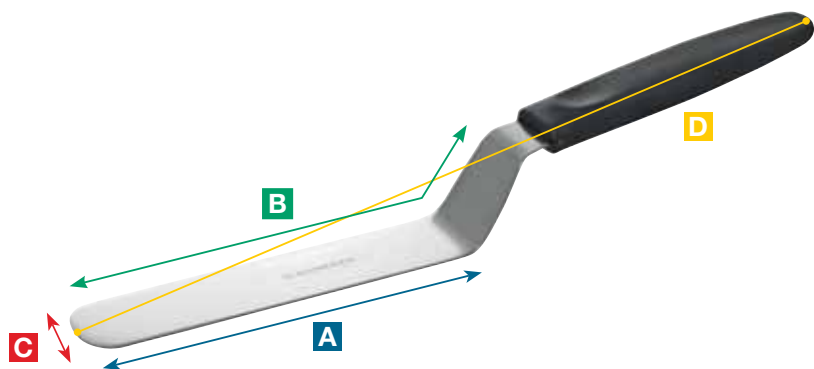

- A** Streichfläche / working surface
- B** Länge der Klinge / length of blade
- C** Breite der Klinge / width of blade
- D** Gesamtlänge / total length

DE	BACK- UND GLASURPALETTEN
EN	PALETTE KNIVES
IT	SPATOLE SMUSSATE
ES	ESPÁTULAS SIN FILO

#	A (mm)	C (mm)	D (mm)
<input checked="" type="checkbox"/> 260035	115 – "MINI"	20	220
<input checked="" type="checkbox"/> 260030	160	34	295
<input checked="" type="checkbox"/> 260031	210	34	350
<input checked="" type="checkbox"/> 260032	260	34	395
<input checked="" type="checkbox"/> 260033	310	34	435
<input checked="" type="checkbox"/> 260034	360	34	495



DE	WINKELPALETTEN – 60°
EN	ANGULAR SPATULAS – 60°
IT	SPATOLE ANGOLARI – 60°
ES	ESPÁTULAS CURVADAS – 60°

#	A (mm)	B (mm)	C (mm)	D (mm)
<input checked="" type="checkbox"/> 260044	90	115	20	220
<input checked="" type="checkbox"/> 260040	110	160	34	280
<input checked="" type="checkbox"/> 260041	160	210	34	330
<input checked="" type="checkbox"/> 260042	210	260	34	375
<input checked="" type="checkbox"/> 260043	250	310	34	415



DE	TORTENRINGPALETTE – 90°
EN	TARTRING SPATULA – 90°
IT	SPATOLA PER ANELLO DA TORTA – 90°
ES	ESPÁTULA PARA ARO DE TARTAS – 90°

#	A (mm)	B (mm)	C (mm)	D (mm)
<input checked="" type="checkbox"/> 260050	185	260	34	350



DE	WINKELPALETTEN
EN	ANGULAR SPATULAS
IT	SPATOLE ANGOLARI
ES	ESPÁTULAS CURVADAS



#	A (mm)	B (mm)	C (mm)	D (mm)
<input checked="" type="checkbox"/> 266055	90	160	34	245



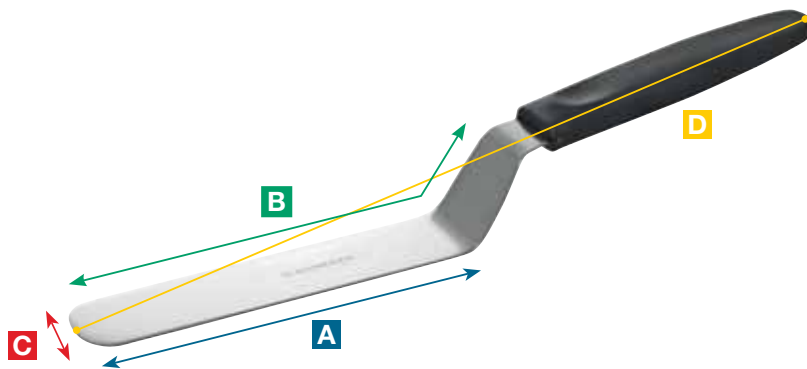

- A** Streichfläche / working surface
- B** Länge der Klinge / length of blade
- C** Breite der Klinge / width of blade
- D** Gesamtlänge / total length



DE	KUCHENPALETTEN – 60°
EN	CAKE SPATULAS – 60°
IT	SPATOLE PER DOLCI – 60°
ES	ESPÁTULAS PARA PASTELES – 60°

#	A (mm)	B (mm)	C (mm)	D (mm)
<input checked="" type="checkbox"/> 260020	100	150	45 – 50	255
<input checked="" type="checkbox"/> 260021	100	150	45 – 50	255

DE	PFANNENWENDER
EN	PAN FLIPPERS
IT	SPATOLE PER HAMBURGER
ES	ESPÁTULAS HAMBURGUESA

#	A (mm)	B (mm)	C (mm)	D (mm)
<input checked="" type="checkbox"/> 260022	200	260	85	375
<input checked="" type="checkbox"/> 260023	200	260	75	380
<input checked="" type="checkbox"/> 260024	120	170	85	290
<input checked="" type="checkbox"/> 260025	230	285	75	400



DE	PIZZAWENDER – 60°
EN	PIZZA FLIPPER – 60°
IT	SPATOLA PER PIZZA – 60°
ES	ESPÁTULA PIZZA – 60°

#	A (mm)	B (mm)	C (mm)	D (mm)
<input checked="" type="checkbox"/> 260000	115	155	90	270



DE	PFANNENWENDER – 60°
EN	PAN FLIPPER – 60°
IT	SPATOLA HAMBURGER – 60°
ES	ESPÁTULA HAMBURGUESA – 60°

#	A (mm)	B (mm)	C (mm)	D (mm)
<input checked="" type="checkbox"/> 260010	185	240	80	355

DE	BRÖTCHENMESSER / KÜCHENMESSER
EN	ROLL KNIVES
IT	COLTELLIINI PER PANINI
ES	CUCHILLOS PARA BOLLITOS DE PAN

- |   |  |
|---|--|
| <ul style="list-style-type: none"> <li>• Klinge: Bandstahl</li> <li>• Wellenschliff</li> <li>• Gesamtlänge: 185 mm</li> <li>• Klingenlänge: 87 mm</li> <li>• Mit Klingenschutz</li> </ul> | <ul style="list-style-type: none"> <li>• Blade: hoop steel</li> <li>• Wave edge</li> <li>• Total length: 185 mm</li> <li>• Blade length: 87 mm</li> <li>• With blade protection</li> </ul> |
|---|--|

#		
260960	● Schwarz / black	
260961	● Orange / orange	
260962	● Rot / red	
260963	● Blau / blue	
260964	● Grün / green	
260965	● Gelb / yellow	



DE	STREICH- UND BUTTERMESSER
EN	SPREADING AND BUTTERING KNIFE
IT	SPALMINI
ES	ESPÁTULAS OVALADAS

#		↗ mm
<input checked="" type="checkbox"/> 260670		90
<input checked="" type="checkbox"/> 260671		120



DE	STREICH- UND BUTTERMESSER MIT WELLENSCHLIFF
EN	SPREADING AND BUTTERING KNIFE WITH WAVY EDGE
IT	SPALMINI
ES	ESPÁTULAS OVALADAS

#		↗ mm
<input checked="" type="checkbox"/> 260672		90
<input checked="" type="checkbox"/> 260673		120



DE	BÄCKER-KLINGE
EN	BAKER BLADE
IT	LAMETTE PER PANETTIERE
ES	CUCHILLAS DEL PANADERO

- |   |  |
|---|--|
| <p>Klinge: Edelstahl</p> <ul style="list-style-type: none"> <li>• Griff und Schutzhülle aus Kunststoff</li> </ul> | <p>Blade made of stainless steel</p> <ul style="list-style-type: none"> <li>• Handle and protection cover made of plastic</li> </ul> |
|---|--|

#		↔ mm
260890		125





DE	BREZEL-SCHNEIDE-SET
EN	PRETZEL CUTTING DEVICE SET INCLUDING KNIFE
IT	SET TAGLIA BREZEL, COLTELLO INCLUSO
ES	DISPOSITIVO DE CORTE CON CUCHILLO PARA PRETZEL

Material: Edelstahl mit Schnittführung  
 • Kunststoffscharnier  
 • Zum praktischen Aufschneiden von Brezeln  
 • Inkl. Messer (200 mm)

Made of stainless steel  
 • Plastic hinge  
 • With guide for quick slicing of pretzels  
 • Including knife (200 mm)

#	↔ mm
154810	195 x 130



DE	THEKEN-DISPLAY „VESPERMESSER“
EN	COUNTER DISPLAY „ALLROUND UTILITY KNIFE“
IT	ESPOSITORE DA BANCO DI COLTELLI
ES	EXPOSITOR DE CUCHILLOS

Vespermesser mit Kunststoffgriff,  
 Micro Schliff  
 • Rostfreier Stahl  
 • 20 Stück pro Display

Allround utility knife with plastic handle,  
 micro ground  
 • Stainless steel  
 • 20 pieces per display



#	Inhalt / content
261800	12 x schwarz , 8 x rot / 12 x black, 8 x red



DE	THEKEN-DISPLAY „FRÜHSTÜCKSMESSER“
EN	COUNTER DISPLAY „BREAKFAST KNIFE“
IT	ESPOSITORE DA BANCO DI COLTELLI DA COLAZIONE
ES	EXPOSITOR DE CUCHILLOS DE DESAYUNO

Frühstücksmesser mit Kunststoffgriff,  
 Micro Schliff  
 • Rostfreier Stahl  
 • 30 Stück pro Display

Allround utility knife with plastic handle,  
 micro ground  
 • Stainless steel  
 • 30 pieces per display



#	Inhalt / content
261810	10 x schwarz , rot, blau / 10 x black, red, blue

**Pflegehinweis:**

Alle Messer und Paletten sind grundsätzlich spülmaschinengeeignet. Die Reinigung in der Spülmaschine ist durch die heute zum Einsatz kommenden Reinigungsmittel jedoch wesentlich aggressiver als die Reinigung von Hand.

Speisemittelreste wie Obstsäuren, hochkonzentriertes Reinigungsmittel oder langes Verbleiben der Messer im heißen Dampf kann auf den Klingen zu Flecken bzw. im schlimmsten Fall zu Rostbildung führen.

Gleichzeitig führen starke chemische Reinigungsmittel zu einem elektrochemischen Abbau der Schneide.

Daher empfehlen wir die Reinigung sofort nach Gebrauch per Hand unter fließendem Wasser mit einem sanften Lappen und einem milden Reinigungsmittel.

Durch ein anschließend sorgfältiges trocken wischen der Messer mit einem weichen Tuch nach dem Reinigen, werden Flecken auf der Klinge vermieden. Außerdem wird die Schneide geschont und bleibt länger scharf.

**Instructions for care**

All knives and cake spatulas are in general dishwasher safe. Cleaning by hand is recommended, thus you prevent that the blade gets in contact with aggressive detergents.

Food remnants such as ascorbic acids, highly concentrated detergents, or prolonged exposure to hot water steam, may cause the blade to stain, or even develop rust, in the worst case.

Strong chemical cleaning agents will at the same time lead to the electrochemical deterioration of the cutting edge.

Right away after each use, we therefore recommend rinsing under running water, using a soft cloth and mild detergent.

Wiping the knife with a soft cloth after cleaning will prevent the blade from developing stains. This will conserve the cutting edge which means it will remain sharper much longer.





**NEW**

DE	KOCHMESSER – SCHMALE KLINGE
EN	CHEF'S KNIVES – NARROW BLADE
IT	COLTELLI DA CUCINA – LAMA STRETTA
ES	CUCHILLOS DE COCINA DE HOJA ESTRECHA



#		↗ mm*
<input checked="" type="checkbox"/> 267000	● Schwarz / black	180

**NEW**

DE	KOCHMESSER – BREITE KLINGE
EN	CHEF'S KNIVES – WIDE BLADE
IT	COLTELLI DA CUCINA – LAMA LARGA
ES	CUCHILLOS DE COCINA DE HOJA ANCHA



#		↗ mm*
<input checked="" type="checkbox"/> 267010	● Schwarz / black	200
<input checked="" type="checkbox"/> 267011	● Schwarz / black	260

**S-GRIP**

- Klingen aus erstklassigem Chrom-Molybdän-Stahl, vakuum-gehärtet, lange Schnitthaltigkeit, Stahlhärte HRC 56°
- Die polierte Klinge sorgt für optimalen Korrosionsschutz, einer hohen Rostbeständigkeit und verhindert Oxidation des Stahls
- Ausbalanciertes Messer für langes und ermüdungsfreies Arbeiten
- Der weiche Griff sorgt für eine rutschfeste Oberfläche und liegt hervorragend in jeder Hand
- Griffkern: PP, Griffmantel aus TPE
- Keine Spaltenbildung zwischen Griff und Klinge
- Perfekt geeignet für Fleisch, Fisch, Obst, Gemüse und Teigwaren

- Blades made of first-class chrome-molybdenum steel, vacuum-hardened, long edge retention, steel hardness HRC 56°
- The polished blade ensures optimum corrosion protection, high rust resistance and prevents oxidation of the steel
- Balanced blade for long and fatigue-free work
- The soft handle provides a non-slip surface and fits perfectly in any hand
- Handle core: PP, outside handle made of TPE
- No gaps between handle and blade
- Perfect for meat, fish, fruit, vegetables and pastry and bakery products



DE	BROTMESSER
EN	BREAD KNIFE
IT	COLTELLI DA PANE
ES	CUCHILLOS PARA PAN

**NEW**

#		↗ mm*
<input checked="" type="checkbox"/> 267020	Welle / wave	200
<input checked="" type="checkbox"/> 267021	Welle / wave	260



DE	SANTOKU
EN	SANTOKU
IT	SANTOKU
ES	SANTOKU

**NEW**

#			↗ mm*
<input checked="" type="checkbox"/> 267030	● Schwarz / black	ohne Kullenschliff / without scalloped edge	180
<input checked="" type="checkbox"/> 267031	● Schwarz / black	mit Kullenschliff / with scalloped edge	180



DE	GEMÜSEMESSER
EN	VEGETABLE KNIVES
IT	COLTELLI PER VERDURE
ES	CUCHILLOS PARA VERDURA

**NEW**

#		↗ mm*
<input checked="" type="checkbox"/> 267040	● Schwarz / black	100



↗ mm\*: Klingenlänge / blade length

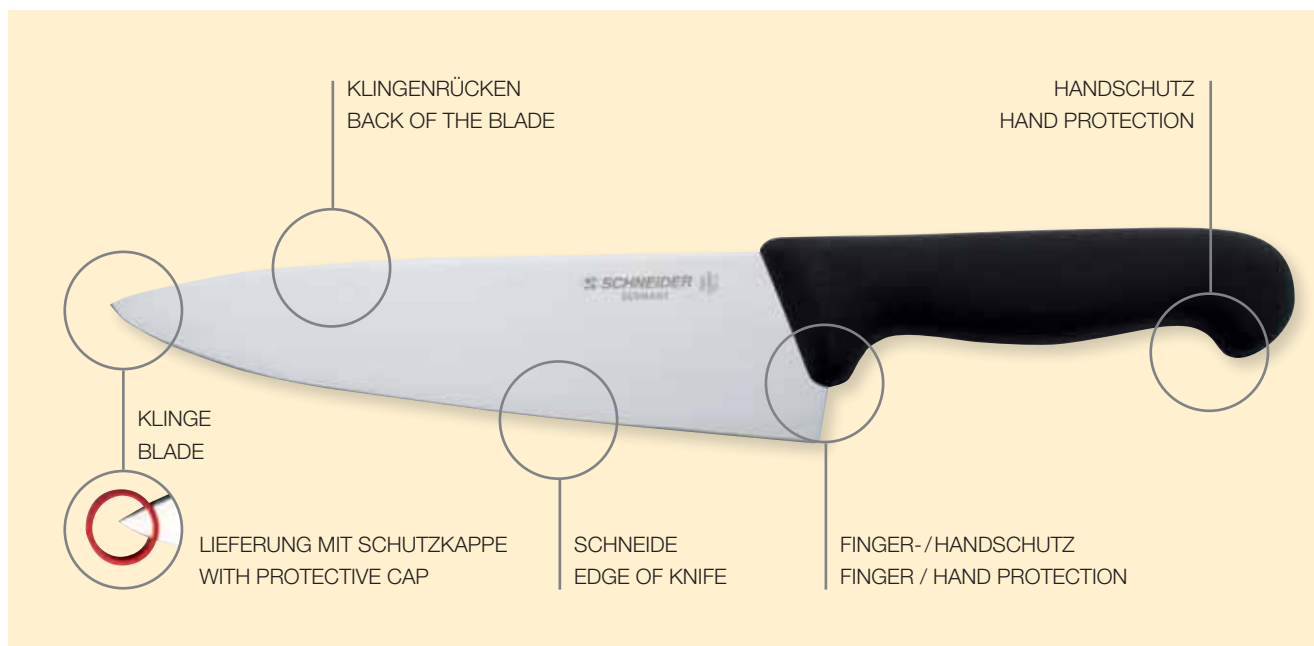

DE	KOCHMESSER – BREITE KLINGE
EN	CHEF'S KNIVES – WIDE BLADE
IT	COLTELLI DA CUCINA – LAMA LARGA
ES	CUCHILLOS DE COCINA DE HOJA ANCHA

	#		↗ mm*	
	<input checked="" type="checkbox"/> 260800	● Schwarz / black	200	
	<input checked="" type="checkbox"/> 260801	● Schwarz / black	260	
	<input checked="" type="checkbox"/> 260802	● Schwarz / black	310	
	<input checked="" type="checkbox"/> 260804	● Rot / red	160	
	<input checked="" type="checkbox"/> 260812	● Rot / red	200	
	<input checked="" type="checkbox"/> 260805	● Blau / blue	160	
	<input checked="" type="checkbox"/> 260813	● Blau / blue	200	
	<input checked="" type="checkbox"/> 260806	● Grün / green	160	
	<input checked="" type="checkbox"/> 260814	● Grün / green	200	
	<input checked="" type="checkbox"/> 260803	● Gelb / yellow	160	
	<input checked="" type="checkbox"/> 260811	● Gelb / yellow	200	
	<input checked="" type="checkbox"/> 260807	● Braun / brown	160	
	<input checked="" type="checkbox"/> 260815	● Braun / brown	200	

**HACCP-KENNZEICHNUNG Verwendungsgebiet / HACCP-MARKING Area of use:**

- |                   |                          |                 |   |
|-------------------|--------------------------|-----------------|---|
| ● Schwarz / black | allgemein / general      | ● Grün / green  | Obst und Gemüse / fruits and vegetables |
| ● Rot / red       | Rohes Fleisch / raw meat | ● Gelb / yellow | Geflügel / poultry meat                 |
| ● Blau / blue     | Fisch / fish             | ● Braun / brown | gekochte Lebensmittel / cooked food     |

↗ mm\*: Klingenlänge / blade length → mm\*: Klingenbreite / blade width

DE	KOCHMESSER – SCHMALE KLINGE
EN	CHEF'S KNIVES – NARROW BLADE
IT	COLTELLI DA CUCINA – LAMA STRETTA
ES	CUCHILLOS DE COCINA DE HOJA ESTRECHA

#		↗ mm*	
<input checked="" type="checkbox"/> 260830	● Schwarz / black	160	
<input checked="" type="checkbox"/> 260831	● Schwarz / black	180	
<input checked="" type="checkbox"/> 260832	● Schwarz / black	200	
<input checked="" type="checkbox"/> 260833	● Rot / red	160	
<input checked="" type="checkbox"/> 260834	● Rot / red	180	
<input checked="" type="checkbox"/> 260835	● Rot / red	200	
<input checked="" type="checkbox"/> 260836	● Blau / blue	160	
<input checked="" type="checkbox"/> 260837	● Blau / blue	180	
<input checked="" type="checkbox"/> 260838	● Blau / blue	200	
<input checked="" type="checkbox"/> 260839	● Grün / green	160	
<input checked="" type="checkbox"/> 260840	● Grün / green	180	
<input checked="" type="checkbox"/> 260841	● Grün / green	200	



DE	SANTOKU
EN	SANTOKU
IT	SANTOKU
ES	SANTOKU

#			↗ mm*	
<input checked="" type="checkbox"/> 260660	● Schwarz / black	ohne Kulle / without scalloped edge	180	
<input checked="" type="checkbox"/> 260661	● Schwarz / black	mit Kullenschliff / with scalloped edge	180	



DE	KEBAB-MESSER
EN	KEBAB KNIVES
IT	COLTELLI KEBAB
ES	CUCHILLOS PARA KEBAB

#		↗ mm*	→ mm*	
<input checked="" type="checkbox"/> 260350	glatte Schneide, harte Klinge/ straight edge, hard blade	500	33	
<input checked="" type="checkbox"/> 260360	glatte Schneide, flexible Klinge/ straight edge, flexible blade	550	33	



DE	GYROS-MESSER
EN	GYROS KNIFE
IT	COLTELLI GYROS
ES	CUCHILLOS PARA GYROS

#		↗ mm*	→ mm*	
<input checked="" type="checkbox"/> 260370	Welle / wave	360	33	



**GLATTER SCHLIFF:** Schneider bietet Ihnen den perfekten Klingenschliff für jeden Einsatzbereich und jede Anforderung. Wählen Sie aus einer Vielzahl von Klingenformen- und -längen.

**PLAIN EDGE:** Schneider provides perfect blades for all types of applications and requirements. Take your pick from a variety of blade shapes and lengths.



**GEZAHNTER SCHLIFF:** Zum Schneiden von Obst und Gemüse mit Haut oder härterer Schale. Die Klinge gleitet mühelos durch die Schale, ohne das Schneidgut zu quetschen.

**SERRATED EDGE:** Suited for the cutting of fruit and vegetables with hard skin. The blade slides effortlessly through the skin without damaging the flesh.



**WELLENSCHLIFF:** Durch regelmäßige Wellen entlang der Klinge gleitet das Messer sicher und ohne abzurutschen durch Schneidgut mit harten Schalen oder Krusten.

**WAVY EDGE:** The regularly grinded waves along the cutting edge enable the knife to slide securely and without slipping through hard peels, rinds and crusts.



DE	GEMÜSEMESSER
EN	VEGETABLE KNIVES
IT	COLTELLI PER VERDURE
ES	CUCHILLOS PARA VERDURA



#		↗ mm*
<input checked="" type="checkbox"/> 260860	● Schwarz / black	100
<input checked="" type="checkbox"/> 260861	● Rot / red	100
<input checked="" type="checkbox"/> 260862	● Blau / blue	100
<input checked="" type="checkbox"/> 260863	● Grün / green	100
<input checked="" type="checkbox"/> 260864	● Gelb / yellow	100
<input checked="" type="checkbox"/> 260865	○ Weiß / white	100

DE	AUSBEINMESSER
EN	BONING KNIFE
IT	COLTELLI PER DISOSSO
ES	CUCHILLOS PARA DESHUESAR



#		↗ mm*
<input checked="" type="checkbox"/> 260876	● Rot / red	150
<input checked="" type="checkbox"/> 260877	● Blau / blue	150

DE	TOURNIERMESSER
EN	BIRD'S BEAK PEELING KNIFE
IT	COLTELLO SPELUCCHINO
ES	CUCHILLO DE PELAR



#		↗ mm*
<input checked="" type="checkbox"/> 260878	● Grün / green	60

↗ mm\*: Klingenlänge / blade length

DE	UNIVERSALMESSER – WELLENSCHLIFF
EN	UNIVERSAL KNIVES – WAVY EDGE
IT	COLTELLI UNIVERSALI
ES	CUCHILLOS UNIVERSALES

#		↗ mm*	
<input checked="" type="checkbox"/> 260700	● Schwarz / black	250	
<input checked="" type="checkbox"/> 260701	● Rot / red	250	
<input checked="" type="checkbox"/> 260702	● Blau / blue	250	
<input checked="" type="checkbox"/> 260703	● Grün / green	250	



DE	UNIVERSALMESSER / TOMATENMESSER – WELLE
EN	UNIVERSAL KNIVES – WAVE
IT	COLTELLI UNIVERSALI DENTATI
ES	CUCHILLOS UNIVERSALES DENTADOS

#		↗ mm*	
<input checked="" type="checkbox"/> 260820	● Schwarz / black	110	
<input checked="" type="checkbox"/> 260819	● Rot / red	110	
<input checked="" type="checkbox"/> 260818	● Blau / blue	110	
<input checked="" type="checkbox"/> 260817	● Grün / green	110	
<input checked="" type="checkbox"/> 260816	● Gelb / yellow	110	



DE	UNIVERSALMESSER
EN	UNIVERSAL KNIVES
IT	COLTELLI UNIVERSALI
ES	CUCHILLOS UNIVERSALES

Speziell für harte Lebensmittel, Hartkäse, Bruchschokolade

Especially for hard foods, hard cheese, broken chocolate

**NEW**

#		↗ mm*	
<input checked="" type="checkbox"/> 260851	Schneide / plain	260	
<input checked="" type="checkbox"/> 260852	Schneide / plain	340	



DE	FILIERMESSER
EN	FILLETING KNIFE
IT	COLTELLI PER SFILETTARE
ES	CUCHILLOS PARA FILETEAR

#		↗ mm*	
<input checked="" type="checkbox"/> 260850	Schneide / plain	160	



16

DE	KÜCHENMESSER
EN	KITCHEN KNIFE
IT	COLTELLI DA CUCINA
ES	CUCHILLO DE COCINA

#		↗ mm*	
<input checked="" type="checkbox"/> 260810	Schneide / plain	130	



DE	AUSBEINMESSER, GERADE KLINGE
EN	BONING KNIVES, STRAIGHT BLADE
IT	COTELLO DISOSSO, LAMA DIRITTA
ES	DESHUESADOR, HOJA RECTA



#		↗ mm*
<input checked="" type="checkbox"/> 268013	● Gelb / yellow	130
<input checked="" type="checkbox"/> 268015	● Gelb / yellow	150

DE	AUSBEINMESSER, HALBFLEXIBLE KLINGE
EN	BONING KNIVES, SEMI-FLEXIBLE BLADE
IT	COTELLO DISOSSO, SEMI FLEX
ES	DESHUESADOR, SEMI FLEX



#		↗ mm*
<input checked="" type="checkbox"/> 268113	● Gelb / yellow	130
<input checked="" type="checkbox"/> 268115	● Gelb / yellow	150

DE	STECHMESSER
EN	STICKING KNIVES
IT	COLTELLO AFFETTARE
ES	CUCHILLO SANGRADO



#		↗ mm*
<input checked="" type="checkbox"/> 268213	● Gelb / yellow	130
<input checked="" type="checkbox"/> 268216	● Gelb / yellow	160
<input checked="" type="checkbox"/> 268218	● Gelb / yellow	180

DE	ZUSCHNEIDEMESSER
EN	BREAKING KNIVES
IT	COLTELLO PER TAGLIARE
ES	CUCHILLO PARA DESPIECE



#		↗ mm*
<input checked="" type="checkbox"/> 268320	● Gelb / yellow	200
<input checked="" type="checkbox"/> 268325	● Gelb / yellow	250

DE	SCHLACHTMESSER
EN	BUTCHER KNIVES
IT	COLTELLO SCIMITARRA
ES	CUCHILLO DE CARNICERO



#		↗ mm*
<input checked="" type="checkbox"/> 268421	● Gelb / yellow	210
<input checked="" type="checkbox"/> 268424	● Gelb / yellow	240

↗ mm\*: Klingenlänge / blade length

**NEW**

DE	UNIVERSALSCHERE
EN	KITCHEN SCISSORS
IT	FORBICI DA CUCINA
ES	TIJERAS DE COCINA

- Zweiflächiger Spezialschliff, ausdauernd scharf
- Bruchfeste, ergonomische Griffe
- Flexibel justierbare Schraubverbindung
- Rostfrei, hygienisch, säurebeständig, anti-allergen
- Inklusive Drehverschlussöffner
- Special two-surface sharpening, long-lasting sharpness
- Break-resistant, ergonomic handles
- Adjustable screw connection
- Stainless, hygienic, acid-resistant, anti-allergenic steel
- With screw cap opener



#	→ mm	↗ mm*
<input checked="" type="checkbox"/> 260908	203	71

DE	ABZIEHSTAHL/WETZSTAHL
EN	SHARPENING STEELS
IT	AFFILATORI
ES	AFILADORES

#		↔ mm
<input checked="" type="checkbox"/> 260900	rund / round	250
<input checked="" type="checkbox"/> 260901	rund / round	310
<input checked="" type="checkbox"/> 260902	oval / oval	250
<input checked="" type="checkbox"/> 260903	oval / oval	310



DE	MESSER-STERILISIERUNGSGERÄT
EN	KNIFE-STERILIZER
IT	STERILIZZATORE PER COLTELLI
ES	ESTERILIZADOR DE CUCHILLOS

- Gehäuse aus Edelstahl, Türe aus Methacrylat. Anti-UV-Dispersion mit Magnetverschluss.
- Sicherheitsschalter für automatisches Ausschalten der Lampe beim Öffnen der Türe
  - Zeiteinstellung 0–60 min.
  - Für ca. 20 Messer
  - Leistung: 16 W
  - Spannung: 230 V / 50 Hz
- Stainless steel housing, methacrylate door. Anti-UV dispersion with magnetic closure.
- Safety switch for automatic switch off the lamp when opening the door
  - Timer 0–60 min.
  - For approx. 20 knives
  - Power: 16 W
  - Voltage: 230 V / 50 Hz



#	↔ mm	⚖ kg
260099	670 x 510 x 130	9

DE	MAGNETLEISTE / MESSERLEISTE
EN	MAGNET BAR
IT	BARRA MAGNETICA
ES	BARRA MAGNÉTICA

- Inklusive Befestigungsmaterial
- Including fittings



#	↔ mm
260910	500



DE	MESSER-ABSTREIFBEHÄLTER – EINBAUGERÄT
EN	KNIFE CLEANER – FOR HANGING INTO COUNTERS
IT	PULISCI COLTELLI – DA INCASSO
ES	CONTENEDOR DE LIMPIEZA CUCHILLOSS – EMPOTRABLE

- |   |   |
|---|---|
| Material: Edelstahl   | Made of stainless steel   |
| <ul style="list-style-type: none"> <li>• Mit Außen- und Innenbehälter</li> <li>• Der Innenbehälter wird zum Wasserwechsel herausgenommen</li> <li>• Mit Schlitzdeckel</li> <li>• Umlaufender Rand 10 mm</li> <li>• Unbeheizt</li> </ul> | <ul style="list-style-type: none"> <li>• With outer and inner container</li> <li>• The inner container can be removed for water exchange</li> <li>• With slot cover</li> <li>• Circulatory edge 10 mm</li> <li>• Without heating</li> </ul> |

#	↑ mm	Ø ↔ mm	↔ mm
270003	180	100	125



DE	MESSER-ABSTREIFBEHÄLTER – STANDGERÄT
EN	STANDING KNIFE CLEANER – WITH SOCKET
IT	PULISCI COLTELLI – DA BANCO
ES	CONTENEDOR DE LIMPIEZA CUCHILLOSS – PARA MESA

- |  |  |
|--|--|
| Material: Edelstahl  | Made of stainless steel  |
| <ul style="list-style-type: none"> <li>• Mit Schlitzdeckel</li> <li>• Unbeheizt</li> </ul> | <ul style="list-style-type: none"> <li>• With slot cover</li> <li>• Without heating</li> </ul> |

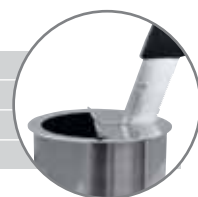

#	↑ mm	Ø ↔ mm	↔ mm
270000	180	100	130



DE	MESSER-ABSTREIFBEHÄLTER – WANDGERÄT
EN	KNIFE CLEANER – FOR WALL-MOUNTING
IT	PULISCI COLTELLI – DA MURO
ES	CONTENEDOR DE LIMPIEZA CUCHILLOSS – PARA MURO

- |   |   |
|---|---|
| Material: Edelstahl   | Made of stainless steel   |
| <ul style="list-style-type: none"> <li>• Mit Außen- und Innenbehälter</li> <li>• Der Innenbehälter wird zum Wasserwechsel herausgenommen</li> <li>• Mit Schlitzdeckel</li> <li>• Umlaufender Rand 10 mm</li> <li>• Inklusive Wandhalterung</li> </ul> | <ul style="list-style-type: none"> <li>• With outer and inner container</li> <li>• The inner container can be removed for water exchange</li> <li>• With slot cover</li> <li>• Circulatory edge 10 mm</li> <li>• Including wall mounting bracket</li> </ul> |

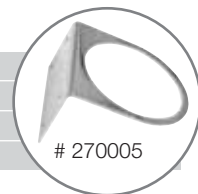

#	↑ mm	Ø ↔ mm	↔ mm
270004	180	100	135
270005	nur Halter passend für / bracket for		# 270003

# 270001

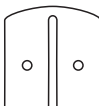

# 270006



#	Ersatzteile / replacement parts
270001	Abstreifgummi/Spare rubber
270002	Bodengummi/round rubber base
270006	Deckel/Lid

DE	SCHNEIDBRETTER	
EN	CUTTING BOARDS	
IT	TAGLIERI	
ES	TABLAS DE CORTAR	

Material: PP

- Ohne FüÙe
- Spülmaschinengeeignet
- Geruchs- und geschmacksneutral
- Schont die Messerklingen
- **Materialstärke: 1,0 cm**

Made of PP

- Without feet
- Dishwasher safe
- Neutral smell and taste
- Protects the knife blades
- **Thickness: 1.0 cm**

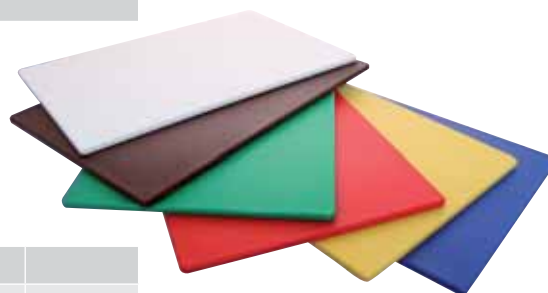

#		↔ mm
228300	○ Weiß / white	450 x 300
228301	● Braun / brown	450 x 300
228302	● Grün / green	450 x 300
228303	● Rot / red	450 x 300
228304	● Gelb / yellow	450 x 300
228305	● Blau / blue	450 x 300

DE	SCHNEIDBRETTER GN 1/1	
EN	CUTTING BOARDS GN 1/1	
IT	TAGLIERI GN 1/1	
ES	TABLAS DE CORTAR GN 1/1	

Material: HD-PE 500

- Mit FüÙen
- Spülmaschinengeeignet
- Schwere Qualität
- Geruchs- und geschmacksneutral
- Schont die Messerklingen
- **Materialstärke: 2,0 cm**

Made of HD-PE 500

- With feet
- Dishwasher safe
- Heavy quality
- Neutral in taste and smell
- Protects the knife blades
- **Thickness: 2.0 cm**

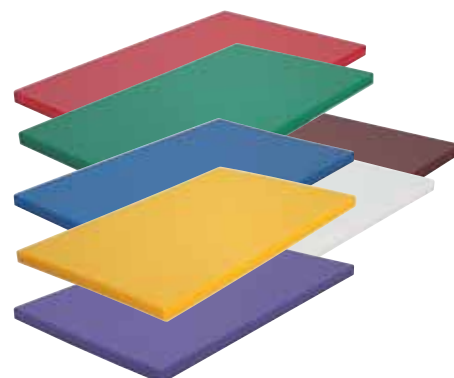

#		↔ mm
228310	○ Weiß / white	530 x 325
228311	● Braun / brown	530 x 325
228312	● Grün / green	530 x 325
228313	● Rot / red	530 x 325
228314	● Gelb / yellow	530 x 325
228315	● Blau / blue	530 x 325
228316	● Lila / purple	530 x 325

DE	SCHNEIDBRETTER	
EN	CUTTING BOARDS	
IT	TAGLIERI	
ES	TABLAS DE CORTAR	

Material: HD-PE 500, weiß

- Mit FüÙen
- Umlaufender Safrinne
- Spülmaschinengeeignet
- Schwere Qualität
- Geruchs- und geschmacksneutral
- Schont die Messerklingen
- **Materialstärke: 2,0 cm**

Made of HD-PE 500, white

- With feet
- Surrounding groove
- Dishwasher safe
- Heavy quality
- Neutral in taste and smell
- Protects the knife blades
- **Thickness: 2.0 cm**



#	↔ mm
228390	400 x 250
228391	500 x 300



GN 1/1

DE	SCHNEIDEBRETT-SET HACCP	
EN	CUTTING BOARD SET HACCP	
IT	SET DI TAGLIERI HACCP	
ES	JUEGO DE TABLAS DE CORTAR HACCP	

Material: HD-PE

- Die stabile Bodenplatte hält die farbigen Schneideunterlagen immer fixiert
- Austauschbar
- Schont die Messerklingen
- Schneideunterlagen: je 3 mm Stärke
- Farben: rot, gelb, grün, blau, weiß, braun

Material: HD-PE

- The stable base plate keeps the colored cutting pads always fixed
- Exchangeable
- Protects the knife blades
- Cutting pads: each 3 mm thick
- Colours: red, yellow, green, blue, white, brown

#	↔ mm	↑ mm
228330	400 x 300	38
228332	400 x 600	38
228333	GN 1/1 – 530 x 325	38

DE	ERSATZ-SCHNEIDEBRETT	
EN	REPLACEMENT CUTTING BOARD	
IT	TAGLIERE DI RISERVA	
ES	TABLAS DE CORTAR DE REPUESTO	

Set á 6 Stk. je Farbe

Set of 6 pcs. per color

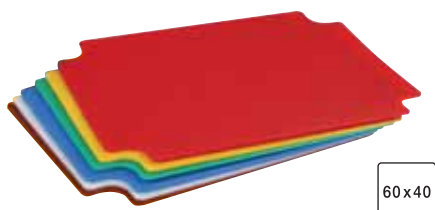

60 x 40

GN 1/1

#		↔ mm
228350	○ Weiß / white	400 x 300
228351	● Braun / brown	400 x 300
228352	● Grün / green	400 x 300
228353	● Rot / red	400 x 300
228354	● Gelb / yellow	400 x 300
228355	● Blau / blue	400 x 300
228360	○ Weiß / white	400 x 600
228361	● Braun / brown	400 x 600
228362	● Grün / green	400 x 600
228363	● Rot / red	400 x 600
228364	● Gelb / yellow	400 x 600
228365	● Blau / blue	400 x 600
228370	○ Weiß / white	GN 1/1 – 530 x 325
228371	● Braun / brown	GN 1/1 – 530 x 325
228372	● Grün / green	GN 1/1 – 530 x 325
228373	● Rot / red	GN 1/1 – 530 x 325
228374	● Gelb / yellow	GN 1/1 – 530 x 325
228375	● Blau / blue	GN 1/1 – 530 x 325

DE	SCHNEIDEBRETT MIT SAFTSCHALE – SET	
EN	CUTTING BOARD WITH DRIPPING TRAY – SET	GN 1/1
IT	TAGLIERE CON VASSOIO DI SGOCCIOLAMENTO	
ES	TABLA DE CORTAR CON BANDEJA DE GOTEO	



Material: HD-PE 500, schwarz

- Auffangschale für Fleischsaft, aus Edelstahl, gezogene Ecken, 325 x 530 x 20 mm
- Mit Füßen
- Abmessungen: 295 x 495 x 20 mm

Made of HD-PE 500, black

- Collecting tray for meat juice, made of stainless steel, drawn corners, 325 x 530 x 20 mm
- With feet
- Dimension: 295 x 495 x 20 mm

#	
228395	1 Set

DE	MULTISTOPPER
EN	MULTISTOPPER
IT	MULTISTOPPER
ES	MULTISTOPPER



- Rutschfeste und elastische Unterlagen aus hochwertigem Silikon
- Sichert jedes Schneidebrett gegen Verrutschen
- Stapelbar und somit individuelle Arbeitshöhen möglich
- Für das Abstellen von heißen Töpfen und Pfannen geeignet
- Wasser- und Schmutzabweisend
- Gleicht Unebenheiten aus
- Spülmaschinenfest bei 80 °C (bis zu 5000 Spülvorgänge)
- Non-slip and elastic underlays made from high-quality silicone
- Secures every cutting board against slipping
- Stackable and therefore individual working heights possible
- Suitable for placing hot pots and pans on
- Water and dirt repellent
- Compensates for unevenness
- Dishwasher-safe at 80 °C (up to 5000 washes)



#		↔ mm
228400	○ Weiß / white	270 x 40
228401	● Schwarz / black	270 x 40
228402	● Rot / red	270 x 40
228403	● Gelb / yellow	270 x 40
228404	● Blau / blue	270 x 40
228405	● Grün / green	270 x 40
228406	● Braun / brown	270 x 40



DE	SCHNEIDEBRETTHOBEL
EN	BOARD SCRAPER
IT	RASCHIETTO
ES	RASCADOR

Material: HD-PE, weiß

Made of HD-PE, white



#	↔ mm
228130	160 x 60
228131	Ersatzklinge / Spare blade

DE	ABTROPFSTÄNDER FÜR 6 SCHNEIDEBRETTER
EN	DRAINING RACK FOR 6 CUTTING BOARDS
IT	SCOLAPIATTI PER 6 TAGLIERI
ES	ESCURREPLATOS PARA 6 TABLAS DE CORTAR

Material: Chromnickelstahl, rostfrei

Made of stainless chrome-nickel steel

#	↔ mm
228340	270 x 270 x 270





Gut präsentiert und gut sortiert – so verkauft es sich am besten!  
 Excellent presentation, Great assortment – Great Sales!

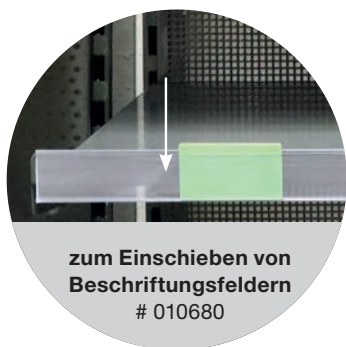



DE	SCANNERSCHIENE / PREISSCHIENE
EN	SCANNER BAR

- Material: PVC, transparent
- Selbstklebend
  - Optimal für Preisschilder oder Produktbeschreibungen
  - Stärke: 2 mm
  - 39 x 1000 mm

- Material: PVC, transparent
- Self-adhesive
  - Optimal for price tags or product descriptions
  - Thickness: 2 mm
  - 39 x 1000 mm



DE	PIZZASCHAUFELTROLLEY	 
EN	PIZZA PEEL DOLLY	
IT	CARRELLO PALA PER PIZZA	
ES	CARRO ESPÁTULA PARA PIZZA	

- Selbstmontage
- Inklusive 16 Schrauben
- Mit Ziehgriff
- 2/4 Lenkrollen feststellbar

- Self-assembly
- Including 16 screws
- With pull handle
- 2/4 swivel castors lockable

#	↗ mm	→ mm	↑ mm	⚖ kg
200680	440	440	483	7,94

SB #	Bezeichnung	Description
410300	Grundregal ohne Fachboden und ohne Haken /	Basic shelf without shelf and without hooks
410310	1x Fachboden 1000 mm x 330 mm	1x Shelf 1000 mm x 330 mm
010626	Schlaufen-Haken, Länge 180 mm, 50 Stück = 1 VE	Loop hook, length 180 mm – 50 pieces = 1 Set
010628	Einfach-Haken, Länge 180 mm, 50 Stück = 1 VE	Single hook, length 180 mm – 50 pieces = 1 Set
410306	Doppel-Schlaufen-Haken 200 mm extra stabil	Loop hook, length 200 mm very stable
410308	Einfach-Haken 200 mm extra stabil	Single hook, length 200 mm very stable
410311	Rollen für SB-Regal	Wheels for basic shelf
010680	Scannerschiene / Preisschiene 39 x 1000 mm	Scanner Bar 39 x 1000 mm

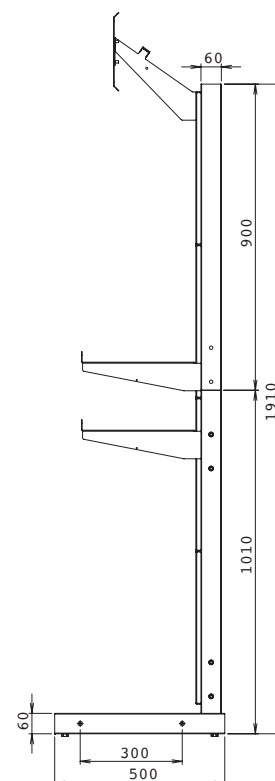
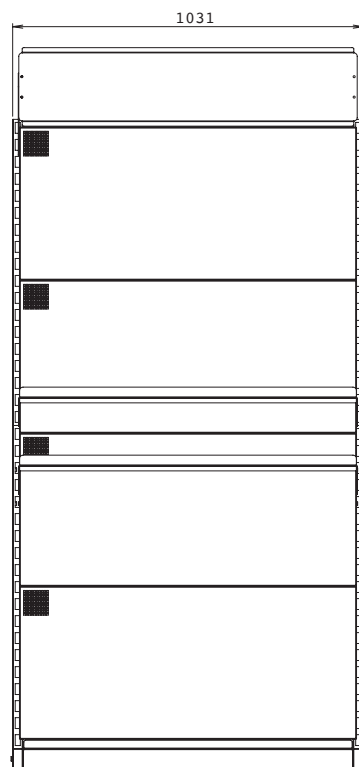
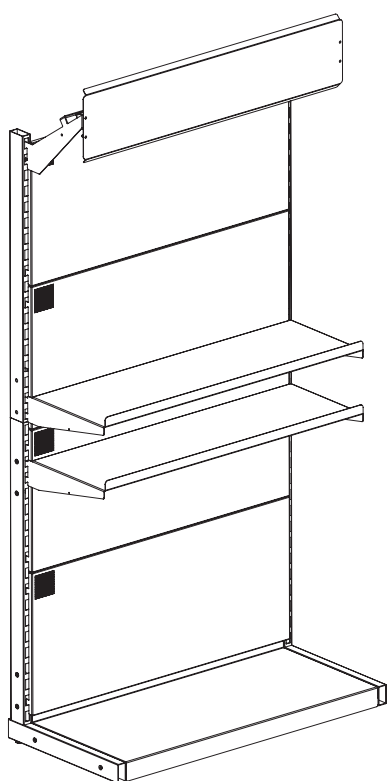

SB #	Bezeichnung	Description	Größe / Size	#
460001	Spritzbeutel	Pastry bag	1 – 28 cm	(350171)
460002	Spritzbeutel	Pastry bag	2 – 34 cm	(350172)
460003	Spritzbeutel	Pastry bag	3 – 40 cm	(350173)
460004	Spritzbeutel	Pastry bag	4 – 46 cm	(350174)
460005	Spritzbeutel	Pastry bag	5 – 50 cm	(350175)
460006	Spritzbeutel-Garnitur 9-tlg.	Pastry bag set 9-pcs.	1a – 31 cm	(350147)
460007	Tüllen-Set Kunststoff, Stern	Star tube set, plastic	3, 5, 7, 9, 11, 13 mm	(196530)
460008	Tüllen-Set Kunststoff, Loch	Plain tube set, plastic	3, 5, 7, 9, 11, 13 mm	(196540)
460009	Tüllen-Set Edelstahl, Stern	Star tube set, stainless steel	4, 6, 8, 10, 13, 15 mm (197552, 197554, 197556, 197558, 197561, 197563)	
460010	Tüllen-Set Edelstahl, Loch	Plain tube set, stainless steel	4, 6, 8, 10, 13, 15 mm (197502, 197504, 197506, 197508, 197511, 197513)	
460029	Abstecher, Edelstahl	Spatula, made of stainless steel	11 x 12 cm	(200600)
460030	Abstecher, Edelstahl	Spatula, made of stainless steel	1 x 12 cm	(200601)
460031	Abstecher, Edelstahl	Spatula, made of stainless steel	13,5 x 13,5 cm	(200602)
460038	Pinsel Holzgriff, 2-er Set	Brush wooden handle, set of 2	3 + 4 cm (200204, 200206)	
460051	Brötchen-Messer, 2-tlg. Set	Roll knives, set 2-pcs.	18 cm	(260961)
460052	Teigschaber-Set	Dough scraper set	4-teilig / 4 pcs. (227364, 227360, 227352, 227365)	
460069	Teig- und Pizzaschneider	Dough and Pizza Cutter	Ø 12,5 cm	(200116)

DE	ARTIKELNUMMERN-INDEX
EN	ITEM NUMBER INDEX
IT	INDICE PER CODICE ARTICOLO
ES	ÍNDICE POR CÓDIGO DEL ARTÍCULO

Art.-Nr. / code	S. / p.	Art.-Nr. / code	S. / p.	Art.-Nr. / code	S. / p.	Art.-Nr. / code	S. / p.	Art.-Nr. / code	S. / p.
<b>01</b>		110550	53	115090	72	116018	186	122024	56
010626	381	110562	53	115091	72	116022	186	122035	56
010628	381	110700	53	115092	73	116026	186	122040	56
010680	380	110720	53	115093	73	116028	186	122045	56
<b>10</b>		110740	53	115094	73	116030	186	122050	56
101000	49	110940	53	115095	81	116033	186	122055	56
101001	49	110957	53	115096	81	116034	186	122060	56
101002	49	111300	49	115097	81	116036	186	122065	56
101003	49	111400	49	115098	73	116038	186	122070	56
101004	49	111410	49	115099	73	116040	186	122075	56
101005	49	111420	49	115131	73	116046	186	122080	56
101006	49	111430	49	115165	54	116100	186	122100	57
101007	49	111440	49	115184	81	116110	186	122105	57
101011	49	111441	49	115211	73	116130	186	122110	57
101040	50	111442	49	115212	73	116210	186	122250	56
101043	50	111443	49	115213	73	116333	186	122260	55
101045	50	113040	184	115215	74	116410	186	122270	56
101050	50	113041	184	115220	74	116430	186	122271	56
101057	50	113042	184	115221	74	116440	186	122272	56
101100	50	113500	185	115223	74	116444	186	122273	56
101120	50	114001	184	115225	74	116450	186	122274	56
101140	50	114002	184	115226	74	116480	186	122275	56
103001	51	114003	184	115227	74	<b>12</b>		122276	56
103032	51, 301	114021	185	115228	74	120100	167	122277	56
103040	51	114022	185	115229	74	120108	148	122400	57
103043	51	114023	185	115230	75	120110	148	122410	57
103045	51	114024	185	115231	75	120112	148	122420	57
103050	51	114026	185	115232	75	120114	148	122430	57
103057	51	114030	185	115233	75	120116	148	122700	57
103078	51, 301	114050	185	115234	75	120118	148	122720	57
103079	51	114051	185	115235	75	120190	148	122740	57
103100	51	114052	185	115254	75	120191	148	122780	57
103140	51	114053	185	115300	77	120192	148	<b>13</b>	
103141	51	114054	185	115302	77	120193	148	131030	338
103150	51	114055	185	115303	77	120194	148	131040	338
104032	51, 301	114056	185	115304	77	120195	148	131050	338
104057	51	114057	185	115307	77	120200	167	131060	338
104100	51	114060	185	115308	77	120400	167	131070	338
104140	51	114061	185	115309	77	120450	167	131080	338
106140	51	115003	71	115310	77	120550	166	131800	338
106152	51	115005	71	115311	77	120551	166	131801	338
107782	54	115007	71	115312	78	120553	166	131802	338
107783	54	115011	71	115313	78	120554	166	132040	338
107784	54	115012	71	115315	78	120555	166	132070	338
107785	54	115014	71	115336	78	120556	166	132090	338
107790	54	115016	71	115338	78	120557	166	<b>14</b>	
107791	54	115017	71	115340	78	120641	192	146003	187
109100	50	115028	71	115341	78	120650	113	146004	187
109140	50	115030	72	115343	78	120651	113	146005	187
<b>11</b>		115036	72	115344	78	120653	113	146006	187
110100	53	115037	72	115345	79	120655	228	146007	187
110108	53	115039	72	115347	79	120800	113	146008	187
110110	53	115043	81	115349	79	120801	113	146040	189
110116	53	115044	81	115350	79	120802	113	147200	302
110140	53	115046	81	115548	260	120810	112	148001	187
110150	53	115050	81	116010	186	120811	112	148002	187
110500	53	115069	72	116013	186	120812	112	148003	187
110520	53	115071	72	116014	186	120950	113, 333	148004	187
110540	53	115072	72	116017	186	120960	113, 333	148005	187

DE	ARTIKELNUMMERN-INDEX
EN	ITEM NUMBER INDEX
IT	INDICE PER CODICE ARTICOLO
ES	ÍNDICE POR CÓDIGO DEL ARTÍCULO

Art.-Nr. / code	S. / p.	Art.-Nr. / code	S. / p.	Art.-Nr. / code	S. / p.	Art.-Nr. / code	S. / p.	Art.-Nr. / code	S. / p.
148006	187	152411	278	152643	269	152971	277	154019	176
148007	187	152412	278	152644	269	152972	277	154020	182
148008	187	152413	281	152645	269	152975	336	154021	174
148016	187	152414	281	152646	269	152990	283	154024	174
148020	187	152416	281	152647	269	152991	283	154025	174
148026	187	152417	281	152648	269	153000	273	154026	174
148032	187	152418	281	152652	268	153001	273	154028	174
148040	187	152419	281	152653	268	153090	325	154030	174
148045	187	152420	279	152654	269	153091	325	154031	174
148050	187	152421	279	152655	270	153092	325	154032	174
148051	187	152422	279	152656	270	153093	324	154033	174
149007	189	152430	279	152657	268	153100	110	154034	174
149008	189	152431	279	152658	270	153110	110	154037	179
149009	189	152432	279	152659	268	153200	110	154040	174
149010	189	152441	278	152660	270	153204	110	154041	174
149900	190	152442	278	152661	268	153210	110	154042	174
<b>15</b>		152450	280	152662	270	153300	110	154043	174
150000	155	152452	280	152663	270	153351	147	154050	177
150590	297	152453	280	152664	270	153352	147	154051	177
150600	337	152454	280	152665	270	153400	110	154052	177
150610	337	152455	280	152666	268	153450	111	154053	177
150620	276	152456	284	152669	272	153451	111	154054	177
150621	277	152460	285	152670	272	153452	111	154055	177
150625	277	152470	284	152671	272	153500	147	154056	177
150630	276	152475	336	152672	272	153510	147	154059	177
150635	276	152480	285	152673	272	153550	147	154060	176
150700	335	152481	285	152674	272	153560	147	154061	176
150710	334	152482	284	152675	272	153600	295	154065	179
150715	334	152490	282	152676	272	153601	295	154066	179
150720	335	152491	282	152677	271	153602	295	154070	177
150730	334	152492	282	152679	267	153603	295	154071	177
150790	335	152493	285	152699	267	153604	295	154072	177
150900	333	152495	282	152700	273	153610	295	154073	177
150910	333	152496	282	152710	267	153620	295	154074	177
150920	333	152497	282	152711	267	153900	298	154080	177
150930	333	152541	278	152712	267	153901	298	154081	177
151065	331	152542	278	152840	264	153902	298	154082	177
151066	331	152543	279	152845	264	153903	298	154083	177
151145	314	152544	279	152851	266	153904	298	154084	177
151170	330	152545	279	152856	266	153905	298	154089	177
151171	330	152547	279	152860	266	153906	298	154090	179
151172	330	152600	264	152861	266	153908	298	154091	179
151175	330	152609	264	152862	266	153909	298	154093	179
151190	330	152610	265	152865	266	153935	298	154094	179
151300	155	152611	265	152880	269	153950	129, 299	154095	176
151301	155	152612	265	152898	271	153952	129, 299	154096	176
152200	274	152613	265	152915	125	153961	298	154098	176
152210	274	152630	268	152916	125	153971	233	154099	176
152230	274	152631	268	152917	125	153975	233	154104	108, 345
152235	274	152632	268	152918	125	153989	233	154203	109
152260	275	152633	269	152919	125	154001	182	154300	108
152280	275	152635	269	152920	125	154002	182	154420	109
152305	285	152636	269	152922	283	154003	182	154421	109
152395	282	152637	272	152923	283	154004	182	154422	109
152400	280	152638	269	152924	283	154010	182	154424	109
152401	280	152639	269	152932	283	154011	179	154427	109
152402	280	152640	269	152933	283	154012	179	154429	109
152403	280	152641	269	152934	283	154018	181	154430	109
152410	278	152642	269	152970	277	154019	176	154499	109

DE	ARTIKELNUMMERN-INDEX
EN	ITEM NUMBER INDEX
IT	INDICE PER CODICE ARTICOLO
ES	ÍNDICE POR CÓDIGO DEL ARTÍCULO

Art.-Nr. / code	S. / p.	Art.-Nr. / code	S. / p.	Art.-Nr. / code	S. / p.	Art.-Nr. / code	S. / p.	Art.-Nr. / code	S. / p.
154702	282	155379	145	156208	141	159260	52	163260	140
154710	283	155380	145	156225	141	159350	52	163280	140
154711	283	155381	145	156226	141	159360	52	163300	140
154712	283	155382	145	156227	141	159450	52	164120	140
154720	283	155383	145	156241	142	159460	52	164140	140
154721	283	155384	145	156245	141	159700	346	164160	140
154722	283	155385	145	156246	141	159701	346	164180	140
154810	360	155386	145	156247	141	159702	346	164200	140
154812	192	155387	145	156261	142	159900	297	164220	140
154813	343	155388	145	156265	141	159902	297	164240	140
154840	103, 225	155389	145	156266	141	<b>16</b>		164260	140
154841	103, 225	155390	145	156267	141	160001	158	164280	140
154842	103, 225	155391	145	156268	141	160002	158	164300	140
154900	67	155399	145	156281	142	160003	158	164400	141
154901	67	155400	145	156282	142	160004	158	164401	141
154903	67	155410	145	156284	141	160005	158	164402	141
155009	87	155420	145	156285	141	160006	160	164900	143
155010	87	155430	145	156286	141	160012	158	166001	92
155011	87	155450	146, 327	156287	141	160014	157	166002	92
155040	174, 225	155451	146, 327	156288	141	160015	105, 158	166003	92
155041	174, 225	155452	146, 327	156301	142	160018	161	166004	92
155042	174, 225	155453	146, 327	156302	142	160019	157	166005	92
155043	174, 225	155454	146, 327	156321	142	160026	159	166006	92
155050	143	155455	146, 327	156322	142	160028	159	166007	92
155051	143	155456	146, 327	156327	141	160029	160	166008	92
155060	144, 326	155500	138	156387	141	160034	159	166009	92
155070	143	156008	56	156465	141	160035	159	166010	92
155071	143	156013	142	156753	141	160036	159	166022	92
155072	143	156014	142	156754	141	160050	156	166023	92
155073	143	156015	142	156853	141	160051	157	166024	92
155074	143	156017	142	156953	141	160052	160	166025	92
155100	144, 326	156075	146, 327	156980	142	160054	161	166026	92
155110	144, 326	156076	146, 327	156981	142	160056	161	166027	92
155120	144, 326	156077	141	157000	203	160100	157	166028	92
155200	144, 326	156078	141	157001	203	161020	159	166029	92
155210	144, 326	156079	141	157002	203	161030	159	166030	92
155220	144, 326	156083	141	157010	142	162080	140	166032	92
155300	144, 326	156110	45, 151, 301	157745	334	162100	140	166034	92
155310	144, 326	156111	45, 151, 301	157760	337	162120	140	166035	92
155320	144, 326	156112	45, 151, 301	157770	337	162140	140	166037	92
155330	144, 327	156113	45, 151, 301	158006	147	162160	140	166080	119
155331	144, 327	156115	150	158010	339	162180	140	166081	119
155332	144, 327	156116	150	158020	339	162200	140	166082	119
155340	144, 327	156124	150	158110	339	162220	140	166083	119
155341	144, 327	156125	151	158120	339	162240	140	166100	82
155342	144, 327	156126	151	158130	339	162260	140	166101	82
155350	144, 327	156128	150	158140	339	162280	140	166102	82
155351	144, 327	156129	150	158150	339	162300	140	166103	82
155352	144, 327	156130	150	158210	339	162320	140	166104	82
155357	145	156131	150	158220	339	162340	140	166105	82
155361	145	156161	141	158310	338	163075	140	166106	82
155363	145	156165	141	158320	338	163080	140	166107	82
155365	145	156166	141	158330	338	163120	140	166108	82
155367	145	156185	141	158410	339	163140	140	166109	82
155369	145	156186	141	158420	339	163160	140	166110	82
155371	145	156187	141	159150	52	163180	140	166120	82
155373	145	156205	141	159160	52	163200	140	166121	82
155375	145	156206	141	159240	52	163220	140	166130	153
155377	145	156207	141	159250	52	163240	140	166140	153

DE	ARTIKELNUMMERN-INDEX
EN	ITEM NUMBER INDEX
IT	INDICE PER CODICE ARTICOLO
ES	ÍNDICE POR CÓDIGO DEL ARTÍCULO

Art.-Nr. / code	S. / p.	Art.-Nr. / code	S. / p.	Art.-Nr. / code	S. / p.	Art.-Nr. / code	S. / p.	Art.-Nr. / code	S. / p.
<b>17</b>		171020	194	175004	307	180310	133	195190	222
170010	121, 321	171030	194	175005	307	180320	133	195210	222
170011	121, 321	171040	193	175006	307	180330	133	195220	222
170012	121, 321	171041	193	175007	307	180340	133	195230	222
170013	121, 321	171042	193	175030	308	180350	133	195250	222
170014	121, 321	171050	193	175032	308	180360	133	195260	222
170015	121, 321	171051	193	175033	308	180370	133	195290	222
170016	120, 320	171052	193	175037	308	180380	133	195400	223
170040	120, 320	171061	193	175040	308	180400	133	195405	223
170041	120, 320	171062	193	175043	308	180410	133	195410	223
170042	120, 320	171063	193	175044	308	180420	133	195415	223
170043	120, 320	171064	193	175047	308	180430	133	195420	223
170044	120, 320	171100	191	176080	308	180440	133	195425	223
170050	121, 321	171101	191	176100	308	180450	133	195430	223
170051	121, 321	171103	191	176120	308	180460	133	195435	223
170052	121, 321	171104	191	176140	308	181014	154	195440	223
170053	121, 321	171105	191	176160	308	181100	154	195450	223
170054	121, 321	171106	191	176180	308	181160	154	195700	225
170070	121, 321	172000	184	177002	310	181170	154	196015	332
170071	121, 321	172001	184	177003	310	181200	154	196020	332
170072	121, 321	172002	184	177004	173	182000	154	196030	332
170073	121, 321	172003	184	177005	173	182005	154	196050	332
170074	121, 321	172100	227	177006	173	182010	154	196060	332
170075	121, 321	172101	227	177007	173	182020	154	196500	220
170079	120, 320	172200	226	177008	173	182030	154	196501	220
170080	120, 320	172201	226	177009	173	182040	154	196502	220
170081	120, 320	172202	226	177010	309	182045	154	196503	220
170082	120, 320	172203	226	177011	309	<b>19</b>		196504	220
170083	120, 320	172204	226	177020	310	190210	223	196505	220
170084	120, 320	172300	225	177021	310	190220	223	196506	220
170085	120, 320	172370	194, 306	177022	310	190230	223	196507	220
170101	131	172401	192	177030	309	190240	223	196520	220
170107	131	172413	194	177031	309	190300	227	196521	220
170108	131	172414	194	177032	309	190305	227	196522	220
170109	131	172415	193	177040	309	190308	227	196523	220
170110	131	172416	193	177041	309	190310	227	196524	220
170111	131	172430	195	177042	309	191095	119	196525	220
170112	131	172431	195	177050	309	193030	326	196526	220
170113	131	172432	195	177060	310	193031	326	196527	220
170114	131	172460	306	178000	308	193032	326	196528	220
170115	131	172461	306	178001	308	193033	326	196530	220
170116	131	172462	306	178002	308	195010	223	196540	220
170117	131	172463	306	178003	308	195015	223	196550	221
170118	131	172464	306	178004	308	195020	223	196560	221
170120	130	172465	306	178005	308	195025	223	196570	221
170121	130	172500	178	178010	312	195030	223	196580	221
170135	130	172510	178	178011	312	195035	223	196600	218
170136	130	172520	179	178012	312	195040	223	196610	218
170137	130	172530	179	<b>18</b>		195045	223	196620	218
170138	130	172600	195	180202	133	195050	223	196630	218
170139	130	172610	195	180210	133	195055	223	196660	218
170140	130	172630	195	180220	133	195060	223	197032	217
170145	130	172670	194	180230	133	195100	222	197033	217
171000	190	172700	176	180240	133	195110	222	197060	217
171001	190	172710	176	180250	133	195120	222	197136	208
171002	190	175000	307	180260	133	195130	222	197180	209
171003	190	175001	307	180270	133	195140	222	197300	211
171004	190	175002	307	180280	133	195150	222	197301	211
171005	190	175003	307	180300	133	195180	222	197302	211

DE	ARTIKELNUMMERN-INDEX
EN	ITEM NUMBER INDEX
IT	INDICE PER CODICE ARTICOLO
ES	ÍNDICE POR CÓDIGO DEL ARTÍCULO

Art.-Nr. / code	S. / p.	Art.-Nr. / code	S. / p.	Art.-Nr. / code	S. / p.	Art.-Nr. / code	S. / p.	Art.-Nr. / code	S. / p.
197303	215	197502	209	198008	152	199030	190	199179	90
197310	210	197503	209	198009	152	199031	329	199180	90
197311	210	197504	209	198010	152	199032	329	199181	90
197312	210	197505	209	198012	152	199033	232	199182	90
197313	210	197506	209	198013	152	199034	232	199183	90
197314	210	197507	209	198014	152	199035	190	199184	90
197315	210	197508	209	198015	152	199036	190	199210	136
197316	210	197509	209	198017	152	199038	190	199211	136
197317	210	197510	209	198840	311	199039	190	199212	136
197318	210	197511	209	198841	311	199052	136	199220	136
197319	210	197512	209	198870	312	199053	136	199221	136
197320	210	197513	209	198871	312	199054	136	199222	136
197321	210	197514	209	198872	312	199055	136	199223	136
197322	210	197515	209	198873	312	199056	136	199328	311
197323	210	197516	209	198874	312	199057	136	199331	311
197324	210	197517	209	198875	312	199058	136	199361	328
197325	210	197518	209	198890	313	199059	322	199362	328
197326	210	197519	209	198891	313	199060	322	199364	329
197327	210	197550	208	198892	313	199061	322	199365	329
197328	210	197551	208	198900	197	199063	322	199370	311
197329	210	197552	208	198901	197	199064	322	199371	311
197330	211	197553	208	198902	197	199065	322	199372	311
197331	211	197554	208	198903	197	199069	135	199373	311
197332	211	197555	208	198904	197	199070	103	199374	311
197333	210	197556	208	198905	197	199075	103	199375	311
197334	210	197557	208	198910	197	199095	312	199400	127
197335	210	197558	208	198911	197	199096	312	199401	127
197336	210	197559	208	198912	197	199097	312	199402	127
197337	210	197560	208	198913	197	199098	312	199403	127
197340	211	197561	208	198914	197	199120	232	199404	127
197400	212	197562	208	198915	197	199121	232	199405	127
197401	212	197563	208	198920	197	199122	232	199406	127
197402	212	197564	208	198950	196	199123	232	199409	326
197403	214	197565	208	198951	196	199124	232	199410	326
197405	212	197566	208	198952	196	199125	232	199411	326
197406	212	197570	215	198960	196	199126	232	199412	326
197407	212	197571	215	198961	196	199128	232	199420	127
197408	212	197572	215	198962	196	199129	232	199421	127
197410	212	197573	215	199000	126, 318	199130	232	199422	127
197411	212	197574	215	199002	126, 318	199150	94	199423	127
197412	213	197575	215	199003	126, 318	199160	143	199424	127
197413	213	197576	216	199004	126, 318	199161	143	199425	127
197414	213	197577	216	199005	126, 318	199162	143	199500	84
197415	213	197578	216	199006	126, 318	199163	96	199501	84
197417	213	197579	216	199007	126, 318	199164	96	199502	84
197418	213	197580	216	199008	126, 318	199165	96	199503	84
197420	213	197581	216	199009	126, 318	199166	96	199504	84
197421	213	197582	216	199010	126, 318	199167	96	199505	84
197422	213	197583	216	199011	126, 318	199168	96	199506	84
197423	214	197584	216	199012	126, 318	199169	96	199507	84
197424	214	197595	217	199013	126, 318	199170	96	199508	84
197425	214	198000	152	199014	126, 318	199171	98	199510	84
197426	214	198001	152	199015	126, 318	199172	98	199511	84
197427	214	198002	152	199017	126, 318	199173	90	199513	86
197428	214	198003	152	199018	126, 318	199174	90	199520	86
197429	214	198004	152	199019	126, 318	199175	90	199530	87
197430	214	198005	152	199026	322	199176	90	199570	98
197500	209	198006	152	199027	322	199177	90	199571	98
197501	209	198007	152	199028	322	199178	90	199580	119

DE	ARTIKELNUMMERN-INDEX
EN	ITEM NUMBER INDEX
IT	INDICE PER CODICE ARTICOLO
ES	ÍNDICE POR CÓDIGO DEL ARTÍCULO

Art.-Nr. / code	S. / p.	Art.-Nr. / code	S. / p.	Art.-Nr. / code	S. / p.	Art.-Nr. / code	S. / p.	Art.-Nr. / code	S. / p.
199581	119	199860	98	200162	112	200312	114	200653	340
199582	119	199870	98	200163	112	200313	114	200660	340
199584	87	199886	96	200164	112	200346	132	200661	340
199585	119	199887	94	200170	135, 319	200347	132	200662	340
199586	119	199888	94	200179	135, 319	200348	132	200663	340
199590	149	199890	94	200182	108, 345	200349	132	200670	340
199591	149	199891	94	200192	128	200350	132	200680	380
199610	224	199892	322	200194	128	200351	132	200700	104, 233
199611	224	199893	322	200195	128	200352	132	200701	104, 233
199612	224	199894	322	200196	128	200353	132	200702	103
199613	224	199895	322	200197	128	200354	132	200703	103
199614	224	199940	296	200200	114	200355	132	200710	104, 233
199615	224	199950	296	200201	114	200408	134, 319	200750	105
199616	224	199960	135	200202	114	200409	134, 319	200751	105
199617	224	199986	143	200203	114	200420	106	200752	105
199618	224	199987	143	200204	114	200423	106	200760	105
199619	224	199988	143	200205	114	200424	106	200761	105
199620	224	199999	296	200206	114	200490	277	200762	105
199621	224	<b>20</b>		200207	114	200491	277	200770	106
199622	224	200001	108, 345	200208	114	200492	277	200771	106
199623	224	200002	108, 345	200209	114	200493	277	200772	106
199624	224	200003	108	200210	114	200494	277	200773	106
199625	224	200004	109	200212	114	200495	277	200802	132
199626	224	200005	111, 347	200213	114	200496	277	200830	31
199629	224	200006	111, 347	200214	114	200499	129	200840	31
199630	224	200007	111, 347	200215	114	200500	104, 306	200850	31
199641	86	200010	134, 319	200216	114	200501	104, 306	200855	31
199642	86	200011	134, 319	200217	114	200502	104, 306	200860	31
199643	86	200012	134, 319	200218	114	200503	104, 306	200865	31
199650	88	200013	134, 319	200219	114	200504	104, 306	200870	31
199651	88	200014	134, 319	200234	112	200600	103	200875	31
199652	88	200015	134, 319	200235	112	200601	103	200880	31
199653	88	200022	122, 124, 317	200236	112	200602	103	200881	31
199654	88	200023	132	200237	112	200610	104, 233	200882	31
199655	88	200024	132	200238	113	200611	104, 233	200890	30
199656	86	200025	132	200239	113	200620	104	200894	30
199657	86	200026	132	200240	137	200621	104	200899	149
199658	86	200027	132	200241	137	200622	104	200900	149
199659	88	200096	112	200245	217	200625	347	200915	149
199660	88	200097	112	200260	113	200626	347	200925	105
199661	88	200102	188	200261	113	200627	347	200926	105
199662	88	200103	188	200271	114	200630	137	200927	105
199663	88	200104	188	200272	114	200631	137	200928	105
199700	94	200105	188	200273	114	200632	137	200929	105
199710	94	200106	188	200274	114	200633	137	200940	107
199720	94	200108	188	200275	114	200634	137	200941	107
199730	94	200109	188	200276	114	200635	137	200942	107
199740	94	200114	109	200280	114	200640	341	200943	107
199750	94	200115	111, 347	200285	115	200641	341	200944	107
199760	96	200116	111, 347	200286	115	200642	341	200945	107
199761	96	200123	112	200287	115	200643	341	200950	146, 327
199770	96	200126	112	200288	115	200644	345	200960	33, 123
199780	98	200127	112	200290	115	200646	345	200962	33, 123
199790	98	200128	112	200291	115	200647	341	200963	33, 39, 123
199800	98	200129	112	200292	115	200648	345	200970	32, 123
199820	98	200149	135, 319	200293	115	200649	345	200971	32, 123
199830	98	200150	135, 319	200299	114	200650	340	201000	118
199840	98	200160	112	200300	137	200651	340	201010	118
199850	98	200161	112	200301	137	200652	340	201020	118

DE	ARTIKELNUMMERN-INDEX
EN	ITEM NUMBER INDEX
IT	INDICE PER CODICE ARTICOLO
ES	ÍNDICE POR CÓDIGO DEL ARTÍCULO

Art.-Nr. / code	S. / p.	Art.-Nr. / code	S. / p.	Art.-Nr. / code	S. / p.	Art.-Nr. / code	S. / p.	Art.-Nr. / code	S. / p.
201030	118	202092	17	203416	139, 346	225290	169	227128	181
201040	118	202094	18	203417	139, 346	226350	170	227129	180
201050	118	202095	39	203418	139, 346	226360	170	227130	173
201200	116	202096	17	203419	139	226370	170	227131	173
201205	116	202097	22	203420	139	226380	170	227132	173
201210	116	202098	32	203421	138	226390	170	227133	173
201220	116	202099	17	203422	138	226420	170	227134	173
201230	116	202170	344	203429	107	226430	170	227135	173
201300	116	202171	344	203430	107	226440	170	227136	173
201302	116	202172	344	203431	107	226450	170	227137	173
201305	116	202173	344	203432	107	226550	170	227138	173
201310	116	202174	344	203433	107	226560	170	227139	173
201320	116	202175	344	203434	107	226570	170	227140	173
201330	116	202176	344	203435	107	226580	170	227141	173
201400	116	202180	33, 123	203436	107	226590	170	227142	168, 173
201410	116	202181	33, 123	203437	107	226650	171	227144	168
201420	116	202200	33	206010	134, 319	226660	171	227150	183
201430	116	202205	33	206011	134, 319	226670	171	227160	183
201440	116	202210	33	206012	134, 319	226680	171	227170	183
201450	116	202215	33	206013	134, 319	226690	171	227180	183
201451	116	202220	33	206014	134, 319	226720	171	227200	153
201500	116	202225	33	206015	134, 319	226730	171	227214	194, 353
201510	116	202294	115	206112	134, 319	226740	171	227220	181
201520	116	202295	115	206113	134, 319	226750	171	227225	180
201600	116	202296	115	206114	134, 319	226850	171	227227	180
201610	116	202297	115	206115	134, 319	226860	171	227229	180
201620	116	202400	188	<b>22</b>		226870	171	227230	101
201630	116	202401	188	220108	148	226880	171	227231	102
201700	116	202402	188	220110	148	226890	171	227232	102
201710	116	202403	188	220112	148	227002	106	227233	102
201720	116	202404	188	220114	148	227003	172	227235	100
201730	116	202405	188	220116	148	227004	172	227240	100
201800	116	202406	188	220118	148	227007	172	227241	100
201810	116	202407	188	220119	148	227008	172	227242	100
201820	116	202408	188	220120	148	227009	172	227243	100
201830	116	202409	188	220122	148	227010	172	227244	100
201850	116	202410	188	220124	148	227011	172	227246	100
201851	116	202411	188	220126	148	227012	172	227247	100
201852	116	202412	188	220128	148	227013	172	227350	101
201901	118	202413	188	221020	124	227014	172	227351	101
201902	118	202414	188	221021	124	227015	172	227352	102
201903	118	203300	112	221022	124	227016	172	227355	102
201904	118	203310	112	221023	124	227023	175	227356	102
201905	118	203400	139	221024	124	227025	180	227360	102
201906	118	203401	139	221025	124	227026	180	227363	102
201907	118	203402	139	221026	124	227027	180	227364	101
202000	32	203403	139	225050	169	227028	181	227365	102
202005	32	203404	139	225060	169	227029	180	227550	178
202010	32	203405	139	225070	169	227031	183	227551	178
202015	32	203406	139	225080	169	227037	183	227552	178
202020	32	203407	139	225090	169	227094	172	227575	48, 184
202025	32	203408	139	225120	169	227095	172	227576	48, 184
202030	32	203409	139	225130	169	227096	172	227577	48, 185
202035	32	203410	139	225140	169	227097	172	227578	48, 185
202085	17	203411	139, 346	225150	169	227098	175	227601	175
202086	21	203412	139, 346	225250	169	227099	60, 106	227611	175
202089	39	203413	139, 346	225260	169	227125	180	227621	175
202090	52	203414	139, 346	225270	169	227126	180	227622	175
202091	52	203415	139, 346	225280	169	227127	180	227640	175

DE	ARTIKELNUMMERN-INDEX
EN	ITEM NUMBER INDEX
IT	INDICE PER CODICE ARTICOLO
ES	ÍNDICE POR CÓDIGO DEL ARTÍCULO

Art.-Nr. / code	S. / p.	Art.-Nr. / code	S. / p.	Art.-Nr. / code	S. / p.	Art.-Nr. / code	S. / p.	Art.-Nr. / code	S. / p.
227650	178	228402	373	260582	356	260850	367	265536	351
227651	178	228403	373	260592	356	260851	367	265626	351
227670	175	228404	373	260600	356	260852	367	265631	351
227671	175	228405	373	260610	355	260860	366	265636	351
227672	175	228406	373	260611	355	260861	366	265826	351
227750	101	<b>23</b>		260612	355	260862	366	265921	352
227752	102	230030	232	260630	354	260863	366	265926	352
227756	102	230102	125	260631	354	260864	366	266055	357
227757	100	230112	125	260632	354	260865	366	266960	54, 296
227763	102	230122	125	260640	354	260868	328	267000	362
227850	101	230129	125	260641	354	260869	328	267010	362
227852	102	230130	124	260642	354	260876	366	267011	362
227856	102	230150	317	260650	355	260877	366	267020	363
227857	100	230160	317	260651	355	260878	366	267021	363
227863	102	<b>25</b>		260652	355	260890	359	267030	363
228128	313	250001	128	260660	365	260900	369	267031	363
228129	313	250002	128	260661	365	260901	369	267040	363
228130	373	250003	128	260670	359	260902	369	268013	368
228131	373	250004	128	260671	359	260903	369	268015	368
228300	371	250005	128	260672	359	260908	369	268113	368
228301	371	250006	128	260673	359	260910	369	268115	368
228302	371	250007	128	260700	367	260960	359	268213	368
228303	371	250008	128	260701	367	260961	359	268216	368
228304	371	250009	128	260702	367	260962	359	268218	368
228305	371	255000	230	260703	367	260963	359	268320	368
228310	371	255010	230	260730	355	260964	359	268325	368
228311	371	255320	228	260740	356	260965	359	268421	368
228312	371	255350	228	260742	356	261800	360	268424	368
228313	371	255800	231	260800	364	261810	360	<b>27</b>	
228314	371	255850	231	260801	364	262518	352	270000	370
228315	371	255860	231	260802	364	262522	352	270001	370
228316	371	255880	231	260803	364	262600	352	270002	370
228330	372	<b>26</b>		260804	364	262601	352	270003	370
228332	372	260000	358	260805	364	262602	352	270004	370
228333	372	260010	358	260806	364	262612	353	270005	370
228340	373	260020	358	260807	364	262616	353	270006	370
228350	372	260021	358	260810	367	262621	353	<b>28</b>	
228351	372	260022	358	260811	364	262626	353	281001	29, 281, 278
228352	372	260023	358	260812	364	262631	353	281002	29
228353	372	260024	358	260813	364	262636	337, 353	281003	29
228354	372	260025	358	260814	364	262640	352	281004	29
228355	372	260030	357	260815	364	262712	353	281005	29
228360	372	260031	357	260816	367	262721	353	281006	29, 281, 278
228361	372	260032	357	260817	367	262726	353	281007	29
228362	372	260033	357	260818	367	262731	353	281008	29
228363	372	260034	357	260819	367	262736	353	281009	29
228364	372	260035	357	260820	367	262825	353	281010	29
228365	372	260040	357	260830	365	264036	350	281011	29, 281, 278
228370	372	260041	357	260831	365	264131	350	281012	29
228371	372	260042	357	260832	365	264136	350	281013	29
228372	372	260043	357	260833	365	264226	350	281014	29
228373	372	260044	357	260834	365	264231	350	281015	29
228374	372	260050	357	260835	365	264236	350	281016	29
228375	372	260099	369	260836	365	264931	351	281017	29
228390	371	260350	365	260837	365	265326	351	281018	29
228391	371	260360	365	260838	365	265426	351	281020	28, 196
228395	372	260370	365	260839	365	265431	351	281021	28, 196
228400	373	260561	355	260840	365	265526	351	281030	28
228401	373	260571	355	260841	365	265531	351	281031	28

DE	ARTIKELNUMMERN-INDEX
EN	ITEM NUMBER INDEX
IT	INDICE PER CODICE ARTICOLO
ES	ÍNDICE POR CÓDIGO DEL ARTÍCULO

Art.-Nr. / code	S. / p.	Art.-Nr. / code	S. / p.	Art.-Nr. / code	S. / p.	Art.-Nr. / code	S. / p.	Art.-Nr. / code	S. / p.
281032	28	350083	200	381109	42	391210	204	421078	240
281033	28	350084	200	381110	42	391220	204	421079	240
281040	23, 29	350085	200	381127	43	391230	204	421081	248
281041	29	350086	200	381150	55	391240	204	421082	248
281042	29	350087	200	381151	55	391320	205	421084	260
<b>29</b>		350088	200	381200	43	391330	205	421089	243
290000	122, 316	350089	200	381201	43	391400	206	421092	250
290010	122, 316	350090	200	381430	48	391410	206	421093	243
290020	122, 316	350144	202	381432	48	391530	166	421094	248
290030	122, 316	350145	202	382000	41	391535	166	421095	243
290040	122, 316, 317	350147	202	382010	41	391550	166	421104	243
290050	122, 316	350170	200	382020	41	391800	204	421129	245
290070	122, 316	350171	200	382030	41	391810	204	421132	258
290071	122, 316	350172	200	382040	41	391820	204	421134	241
290072	122, 316	350173	200	382100	42	391850	206	421145	235
290073	122, 316	350174	200	382110	42	391900	203	421146	235
290074	122, 316	350175	200	382325	48	391901	203	421147	236
290075	122, 316	350176	200	382500	44, 300	391902	203	421148	236
290160	331	350177	200	382501	44, 300	391920	205	421156	251
290170	331	350178	200	382502	44, 300	391950	36	421157	256
290200	124, 233, 316	350179	200	382510	44, 300	391951	36	421158	255
290300	317	350180	200	382511	44, 300	391952	36	421170	260
292000	315	350199	207	382512	44, 300	391953	36	421173	251
292001	315	350250	201	382520	44, 300	391954	36	421189	248
292002	315	350251	201	382521	44, 300	391960	36	421191	243
292003	315	350252	201	382522	44, 300	391961	36	421197	241
292004	315	350253	201	382530	45, 301	391970	36	421209	239
292005	315	350254	201	382531	45, 301	391971	36	421214	235
292006	315	350255	201	382532	45, 301	391972	36	421217	255
292007	315	350256	201	382533	45, 301	391980	36, 53	421218	236
292008	315	350257	201	382534	45, 301	399000	207	421219	242
<b>31</b>		350258	201	382535	45, 301	<b>41</b>		421224	246
310001	162	350259	201	382536	45, 301	410300	381	421226	243
310002	162	350260	201	382562	44, 300	410306	381	421251	237
310003	162	350600	202	383052	41	410308	381	421252	237
310004	165	350601	202	383110	42	410310	381	421253	237
310009	165	350650	202	383200	43	410311	381	421254	237
310019	163	<b>38</b>		385000	34	<b>42</b>		421255	238
310023	164	381000	43	385009	37	421002	255	421256	258
310024	164	381005	43	385010	34	421003	255	421258	255
310027	165	381006	43	385015	35	421006	245	421263	248
310031	163, 323	381007	43	385029	37	421012	235	421266	237
310032	163, 323	381020	43	385030	34	421015	243	421280	235
310085	163, 323	381021	43	385035	35	421019	244	421290	242
310090	165	381022	43	385040	34	421023	235	421291	256
310099	163, 323	381050	41	385050	34	421024	248	421292	256
310103	162	381051	41	385099	37	421025	248	421294	260
310111	164	381052	41	385100	35	421027	243	421296	235
310115	164	381054	41	385120	35	421028	250	421300	242
<b>33</b>		381057	41	385180	34	421031	248	421301	248
330002	201	381058	41	385200	35	421033	241	421302	240
330003	201	381060	41	385205	35	421036	248	421317	237
330004	201	381061	42	385500	38	421037	242	421321	247
330005	201	381063	41	385510	38	421045	248	421327	244
330007	201	381100	42	385550	38	421046	243	421330	251
<b>35</b>		381101	42	385551	38	421048	241	421333	240
350080	200	381102	42	<b>39</b>		421048	241	421333	240
350081	200	381106	42	391050	206	421050	237	421342	255
350082	200	381108	42	391200	204	421053	237	421354	260
						421058	241	421357	247

DE	ARTIKELNUMMERN-INDEX
EN	ITEM NUMBER INDEX
IT	INDICE PER CODICE ARTICOLO
ES	ÍNDICE POR CÓDIGO DEL ARTÍCULO

Art.-Nr. / code	S. / p.	Art.-Nr. / code	S. / p.	Art.-Nr. / code	S. / p.	Art.-Nr. / code	S. / p.	Art.-Nr. / code	S. / p.
421362	237	421643	246	421885	250	422371	254	530023	288
421367	257	421646	252	421887	247	422395	239	530025	289
421383	237	421647	249	421888	238	422431	244	530030	288
421384	242	421648	256	421889	238	422432	242	530031	288
421387	255	421655	240	421891	238	422436	259	530032	288
421393	242	421656	238	421892	236	422437	259	530033	288
421397	248	421664	238	421893	236	422438	259	530035	289
421406	240	421665	258	421898	258	429990	234	530040	288
421411	245	421666	245	421899	258	429991	234	530041	288
421417	235	421667	258	421901	244	429992	234	530042	288
421419	251	421669	241	421903	250	429993	234	530043	288
421421	257	421673	249	421904	250	429994	234	530045	289
421423	246	421674	246	421905	252	429995	234	530050	288
421428	246	421676	249	421906	252	429996	234	530051	288
421431	257	421685	259	421907	239	429997	234	530055	289
421439	240	421726	235	421908	252	429998	234	530060	289
421443	246	421727	245	421909	257	429999	234	530061	289
421456	247	421739	238	421910	239	<b>43</b>		530062	289
421479	251	421744	236	421911	252	430000	261	530063	289
421480	260	421745	258	421912	253	430001	261	530064	289
421483	243	421746	245	421915	253	430007	261	530070	289
421495	256	421753	252	421916	253	430008	261	530071	289
421513	235	421754	252	421917	241	<b>45</b>		530072	289
421516	237	421760	249	421919	244	450500	229	530073	289
421519	241	421764	252	421921	253	450510	229	530074	289
421521	251	421769	259	421922	253	450520	229	530100	290
421526	235	421779	249	421923	253	450900	260	530101	290
421529	244	421780	252	421924	253	<b>46</b>		530102	290
421533	249	421781	249	421929	253	460001	381	530103	290
421537	237	421782	252	421930	253	460002	381	530105	291
421540	244	421784	249	421931	245	460003	381	530110	290
421544	251	421786	238	421932	253	460004	381	530111	290
421545	251	421794	249	421933	245	460005	381	530112	290
421555	251	421795	247	421934	245	460006	381	530113	290
421558	244	421796	258	421935	253	460007	381	530115	291
421559	251	421797	256	421936	253	460008	381	530120	290
421561	242	421799	249	421937	235	460009	381	530121	290
421564	251	421826	241	421938	245	460010	381	530122	290
421568	241	421830	241	421939	254	460029	381	530123	290
421575	251	421840	250	422022	256	460030	381	530125	291
421576	236	421847	247	422037	239	460031	381	530130	290
421582	238	421848	250	422038	240	460038	381	530131	290
421585	255	421853	247	422054	247	460051	381	530132	290
421586	260	421854	258	422110	259	460052	381	530133	290
421588	258	421858	250	422116	256	460069	381	530135	291
421597	247	421859	250	422121	236	<b>53</b>		530140	290
421611	258	421865	247	422122	236	530000	288	530141	290
421612	259	421866	250	422162	259	530001	288	530142	290
421617	252	421867	257	422169	249	530002	288	530143	290
421622	250	421868	240	422251	256	530003	288	530145	291
421623	260	421869	240	422252	256	530005	289	530150	290
421628	246	421870	240	422253	257	530010	288	530151	290
421630	252	421872	258	422254	257	530011	288	530155	291
421635	239	421873	238	422276	259	530012	288	530195	289, 291
421637	241	421874	245	422295	257	530013	288	530196	289, 291
421638	249	421877	244	422343	243	530015	289	530197	289, 291
421640	238	421878	240	422360	247	530020	288	530198	289, 291
421641	238	421880	244	422361	256	530021	288	530199	289, 291
421642	259	421883	250	422370	244	530022	288	530200	45, 292

DE	ARTIKELNUMMERN-INDEX
EN	ITEM NUMBER INDEX
IT	INDICE PER CODICE ARTICOLO
ES	ÍNDICE POR CÓDIGO DEL ARTÍCULO

Art.-Nr. / code	S. / p.	Art.-Nr. / code	S. / p.	Art.-Nr. / code	S. / p.	Art.-Nr. / code	S. / p.	Art.-Nr. / code	S. / p.
530201	45, 292	530310	293	640180	20	<b>91</b>		995841	46
530202	45, 292	530311	293	640220	20	910020	61	995860	47
530203	45, 292	530312	293	640260	20	910025	61	995870	47
530204	292	530320	293	640360	20	910030	61	995880	47
530205	292	530321	293	640640	22	910035	61	995890	47
530206	293	530322	293	640691	23	912030	66	997140	342
530207	293	530490	293	640692	23	912035	66	997160	342
530210	292	530491	293	640699	23	915120	59	997180	342
530211	292	531000	304	640900	21	915122	59	997200	342
530212	292	531001	304	640990	20	915124	59	997220	342
530213	292	531002	304	<b>65</b>		915126	59	997240	342
530214	292	531003	304	650165	26, 348	915128	59	997260	342
530215	292	531004	304	650240	26, 348	<b>92</b>		997280	342
530216	293	531005	304	650330	26, 348	920000	62	997300	342
530217	293	531006	304	650395	26, 348	926820	59	997320	342
530220	292	531010	304	650990	26, 348	926822	59	997340	342
530221	292	531011	304	651165	27, 349	926824	59	997360	342
530222	292	531012	304	651260	27, 349	926826	59	997380	342
530223	292	531013	304	651990	27, 349	926828	59	997400	342
530224	292	531014	304	652280	27, 349	<b>93</b>		997450	342
530225	292	531015	304	652990	27, 349	930020	59	997500	342
530226	293	531020	305	<b>66</b>		<b>94</b>		997620	343
530227	293	531021	305	660215	24	940025	62	997621	343
530230	292	531022	305	660270	24	940027	62	997622	343
530231	292	531023	305	660990	25	949928	61	997623	343
530232	292	531024	305	<b>69</b>		949930	61	997624	343
530233	292	531030	305	690000	16, 23	949932	61	997625	343
530234	292	531031	305	690010	16	<b>95</b>		997630	343
530235	292	531032	305	690020	21	951012	63	997631	343
530236	293	531040	305	690030	27, 349	951014	63	997632	343
530237	293	531041	305	690100	17	951016	63	997633	343
530240	292	531042	305	<b>71</b>		<b>96</b>		997634	343
530241	292	531050	303	710000	197	960020	64	997635	343
530242	292	531051	303	711000	197	967028	60	997636	343
530243	292	531052	303	<b>90</b>		967040	63	997637	343
530244	292	531060	305	900020	60	967040	63	997638	343
530245	292	531061	305	900024	60	967050	64	997639	343
530246	293	531062	305	900026	60	967060	64	997640	343
530247	293	531063	305	900028	60	967065	64	997641	343
530250	292	531064	305	901050	63	967070	64	997642	343
530251	292	531065	305	901314	59	967075	63	997660	343
530252	292	531066	305	901316	59	968000	65	997810	46
530253	292	531070	303	901318	59	968010	65	997811	46
530256	293	531071	303	901320	59	968020	65	997820	46
530257	293	531072	303	901322	59	968030	65	997821	46
530260	292	<b>62</b>		901322	59	968040	65	997840	46
530261	292	620180	15	901324	59	968050	65	997841	46
530266	293	620230	15	901326	59	<b>98</b>		997890	47
530267	293	620280	15	902028	60	981040	66	997899	47
530270	292	620320	15	902032	60	981041	66	997900	342
530271	292	620660	18	904024	61	<b>99</b>		997901	342
530272	292	620900	16, 25	904026	61	994628	62	997902	342
530282	292	620910	16, 25	904028	61	994633	62	997903	342
530283	292	620920	16, 25	904030	61	994860	47	997904	342
530284	292	620990	16	904032	61	995810	46	997910	68
530286	293	<b>63</b>		904034	61	995811	46	997911	68
530300	293	630280	19	904036	61	995820	46	997912	68
530301	293	630990	19	904524	61	995821	46	997913	68
530302	293	<b>64</b>		904526	61	995830	46	997914	68
				904528	61	995840	46	997920	68

DE	ARTIKELNUMMERN-INDEX
EN	ITEM NUMBER INDEX
IT	INDICE PER CODICE ARTICOLO
ES	ÍNDICE POR CÓDIGO DEL ARTÍCULO

Art.-Nr. / code	S. / p.	Art.-Nr. / code	S. / p.	Art.-Nr. / code	S. / p.	Art.-Nr. / code	S. / p.	Art.-Nr. / code	S. / p.
997921	68								
997941	69								
997942	69								
997943	69								
997944	69								
997976	68								
997977	68								
997986	69								
997987	69								
997988	69								

# MATERIALEIGENSCHAFTEN

Material	Eigenschaften	Temperaturbeständigkeit	Pflegehinweis
<b>AC</b> Acryl	Nicht spülmaschineneeignet, sehr gute Oberflächenhärte, hochtransparent	-40 / +50 °C	Reinigung mit einem feuchten Tuch und Spezialreiniger
<b>ABS</b> Acrylnitril-Butadien-Styrol	Bedingt spülmaschineneeignet, sehr gute Oberflächenhärte, temperaturwechselfest, bruchstabil, kratzfest	-30 / +80 °C	Reinigung mit einem feuchten Tuch und mildem Spülmittel, Material kann stumpf werden
<b>ALU</b> Aluminium	Nicht spülmaschineneeignet, bedingt säurebeständig, sehr gute Wärmeleitfähigkeit	+250 °C	Reinigung mit einem feuchten Tuch oder Schwamm und mildem Spülmittel, Verfärbungen sind möglich
<b>SST</b> Edelstahl	Spülmaschineneeignet, temperaturbeständig, lange Lebensdauer	+500 °C	Ggf. Edelstahlreiniger, keine Stahlwolle verwenden
<b>EPP</b> Expandiertes Polypropylen	Spülmaschineneeignet, hohe Isoliereigenschaften, bruchstabil, sehr leicht, recyclebar	-40 / +120 °C	Keine aggressiven Reinigungsmittel verwenden
<b>Exoglass</b>	Spülmaschineneeignet, unzerbrechlich, sterilisierbar	+220 °C	Keine aggressiven Reinigungsmittel verwenden
<b>HDPE</b> Polyethylen mit hoher Dichte Niederdruckverfahren	Bedingt spülmaschineneeignet, hart elastisch, unzerbrechlich, recyclebar	-40 / +95 °C	
<b>WOOD</b> Holz	Nicht spülmaschineneeignet, Naturprodukt, keine homogene Oberfläche		Reinigung mit einem feuchten Tuch, nach Reinigung sofort trocknen
<b>HPVC</b> Hart-Polyvinylchlorid	Nicht spülmaschineneeignet, nicht mikrowelleneeignet, transparent	0 / +60 °C	Reinigung mit einem feuchten Tuch
<b>COPPER</b> Kupfer	Nicht spülmaschineneeignet, die Nutzung mit sauren Nahrungsmitteln, wie Tomaten, Zitronen, Essig oder Wein ist zu vermeiden, da diese durch den Kontakt mit Kupfer oxidieren	Erhitzen Sie das Kochgeschirr mit höchstens 2/3 der maximalen Hitze Ihres Herdes	Nur Handwäsche wird empfohlen
<b>LDPE</b> Polyethylen mit niedriger Dichte Hochdruckverfahren	Bedingt spülmaschineneeignet, weich elastisch, unzerbrechlich, recyclebar, in heißem Wasser ausreichend formbeständig	-40 / +135 °C	
<b>MF</b> Melamin	Bedingt spülmaschineneeignet, hart, sterilisierbar, stoßfest, säurebeständig	-30 / +70 °C	Keine aggressiven Reinigungsmittel verwenden, nicht über 70 °C reinigen
<b>PA</b> Polyamid	Bedingt spülmaschineneeignet, starr, bruch- und schlagfest, mattglänzend	-40 / +120 °C	Keine Intensivreiniger verwenden
<b>PC</b> Polycarbonat	Bedingt spülmaschineneeignet, nicht mikrowelleneeignet, sterilisierbar, unzerbrechlich, sehr stabil	-30 / +135 °C	Reinigung mit einem feuchten Tuch und mildem Spülmittel, Material kann stumpf werden
<b>PE</b> Polyethylen	Bedingt spülmaschineneeignet, bei Einhalten der Temperatur formbeständig	-40 / +80 °C	Nicht über 80 °C reinigen
<b>PET</b> Polyethylenterephthalat	Spülmaschineneeignet, flexibel, bei Einhalten der Temperatur formbeständig	-20 / +110 °C	Keine Intensivreiniger verwenden
<b>POM</b> Polyoxymethylen	Spülmaschineneeignet, sehr hart, bei Einhalten der Temperatur formbeständig, temperaturwechselfest	-40 / +120 °C	Keine Intensivreiniger verwenden
<b>PTFE</b> Polytetrafluorethylen	Spülmaschineneeignet, hoher Antihafteffekt, nicht kratzfest	-70 / +200 °C	Die Beschichtung ist nicht kratzfest, es wird Kunststoff oder Holzequipment zum Arbeiten empfohlen, Vermeidung von Überhitzung
<b>PP</b> Polypropylen	Spülmaschineneeignet, sterilisierbar, unzerbrechlich, sehr stabil, bei Einhalten der Temperatur formbeständig	-40 / +80 °C	Nicht über 80 °C reinigen
<b>PS</b> Polystyrol	Spülmaschineneeignet, sterilisierbar, in heißem Wasser ausreichend formbeständig	-40 / +80 °C	Nicht über 80 °C reinigen
<b>PVC</b> Polyvinylchlorid	Nicht spülmaschineneeignet, nicht mikrowelleneeignet, hohe Reißfestigkeit, abriebfest, resistent gegen verdünnte Säuren und Laugen, säurebeständig	-20 / +100 °C	Reinigung mit einem feuchten Tuch
<b>SI</b> Silikon	Spülmaschineneeignet, hoher Antihafteffekt, flexibel, empfindliche Oberfläche	+280 °C	Backbleche mit Silikonbeschichtung sind nicht spülmaschineneeignet!
<b>STEEL</b> Stahl / Stahlblech (Blaustahl)	Nicht spülmaschineneeignet, sehr gute Wärmeleitfähigkeit, schwer, nicht rostfrei, praktisch nicht überhitzbar		Auf die Beschichtung muss geachtet werden, eine trockene Lagerung wird empfohlen, sowie man das Produkt immer leicht einfetten sollte
<b>SAN</b> Styrol-Acrylnitril	Bedingt spülmaschineneeignet, starr, hochglänzend, kratz-, stoß- und schlagfest	+95 °C	Keine Intensivreiniger verwenden
<b>Cr</b> verchromt	Nicht spülmaschineneeignet, nicht säurefest, temperaturbeständig, glänzend	+40 °C	Reinigung mit einem feuchten Tuch und mildem Spülmittel, keine aggressiven Reinigungsmittel verwenden

(artikelspezifische Abweichungen)

# MATERIAL PROPERTIES

Material	Properties	Temperature resistance	Care instructions
<b>AC</b> Acrylic	Not dishwasher safe, very good surface hardness, highly transparent	- 40 / +50 °C	Cleaning with a damp cloth and special cleaner
<b>ABS</b> Acrylonitrile butadiene styrene	Conditionally dishwasher safe, very good surface hardness, thermal-shock-resistant, break-proof, scratch-proof	-30 / +80 °C	Clean with a damp cloth and mild detergent, material can become dull
<b>ALU</b> Aluminium	Not dishwasher safe, conditionally acid-resistant, very good thermal conductivity	+250 °C	Cleaning with a damp cloth or sponge and mild detergent, discoloration is possible
<b>SST</b> Stainless steel	Dishwasher safe, temperature-resistant, long-lasting	+500 °C	Stainless steel cleaner if necessary, do not use steel wool
<b>EPP</b> Expanded polypropylene	Dishwasher safe, high insulating properties, break-proof, very light, recyclable	- 40 / + 120 °C	Do not use aggressive cleaning agents
<b>Exoglass</b>	Dishwasher safe, unbreakable, sterilizable	+220 °C	Do not use aggressive cleaning agents
<b>HDPE</b> High density polyethylene Low pressure process	Conditionally dishwasher safe, hard elastic, unbreakable, recyclable	- 40 / +95 °C	
<b>WOOD</b> Wood	Not dishwasher safe, natural product, no homogeneous surface		Clean with a damp cloth, dry immediately after cleaning
<b>HPVC</b> Rigid polyvinyl chloride	Not dishwasher safe, not microwave safe, transparent	0 / + 60 °C	Cleaning with a damp cloth
<b>COPPER</b> Copper	Not dishwasher safe, avoid use with acidic foods such as tomatoes, lemons, vinegar or wine, as they will oxidize on contact with copper	Heat the cookware at no more than 2/3 of the maximum heat of your stove	Only hand wash is recommended
<b>LDPE</b> Polyethylene with low density High pressure process	Conditionally dishwasher safe, soft elastic, unbreakable, recyclable, sufficiently dimensionally stable	- 40 / + 135 °C	
<b>MF</b> Melamine	Conditionally dishwasher safe, hard, sterilizable, shock-resistant, acid-resistant	- 30 / + 70 °C	Do not use aggressive cleaning agents, do not clean above 70 °C
<b>PA</b> Polyamide	Conditionally dishwasher safe, rigid, break and impact-resistant, matt shiny	- 40 / + 120 °C	Do not use intensive cleaning agents
<b>PC</b> Polycarbonate	Conditionally dishwasher safe, not microwave safe, sterilizable, unbreakable, very stable	- 30 / + 135 °C	Clean with a damp cloth and mild detergent, material can become dull
<b>PE</b> Polyethylene	Conditionally dishwasher safe, dimensionally stable dimensionally stable when the temperature is observed	- 40 / + 80 °C	Do not clean above 80 °C
<b>PET</b> Polyethylene terephthalate	Dishwasher safe, flexible, dimensionally stable when the temperature is observed	- 20 / + 110 °C	Do not use intensive cleaning agents
<b>POM</b> Polyoxymethylene	Dishwasher safe, very hard, dimensionally stable when the temperature is observed, thermal-shock-resistant	- 40 / + 120 °C	Do not use intensive cleaning agents
<b>PTFE</b> Polytetrafluoroethylene	Dishwasher safe, high non-stick effect, not scratch resistant	- 70 / + 200 °C	The coating is not scratch-resistant, plastic or wooden equipment is recommended for working, avoid overheating
<b>PP</b> Polypropylene	Dishwasher safe, sterilizable, unbreakable, very stable, dimensionally stable dimensionally stable when the temperature is observed	- 40 / + 80 °C	Do not clean above 80 °C
<b>PS</b> Polystyrene	Dishwasher safe, sterilizable, sufficiently dimensionally stable in hot water	- 40 / + 80 °C	Do not clean above 80 °C
<b>PVC</b> Polyvinyl chloride	Not dishwasher safe, not microwave safe, high tear resistance, abrasion resistant, resistant to diluted acids and alkalis, acid-resistant	- 20 / + 100 °C	Cleaning with a damp cloth
<b>SI</b> Silicone	Dishwasher safe, high non-stick effect, flexible, sensitive surface	+ 280 °C	Baking trays with silicone coating are not dishwasher safe!
<b>STEEL</b> Steel / sheet steel (blue steel)	Not dishwasher safe, very good thermal conductivity, heavy, not rust-proof, practically not overheatable		Attention must be paid to the coating, dry storage is recommended, as well as you should always lightly grease the product
<b>SAN</b> Styrene acrylonitrile	Conditionally dishwasher safe, rigid, high shiny, scratch, shock and impact-resistant	+ 95 °C	Do not use intensive cleaning agents
<b>Cr</b> chrome-plated	Not dishwasher safe, not acid-resistant, temperature-resistant, shiny	+ 40 °C	Clean with a damp cloth and mild detergent, do not use aggressive cleaning agents

(item specific deviations)

## MATERIAL PIKTOGRAMME | MATERIAL PICTOGRAMS

<b>ABS</b>	ABS Kunststoff / ABS plastic
<b>AC</b>	Acryl / Acrylic
<b>ALU</b>	Aluminium / Aluminium
<b>COP PER</b>	Kupfer / Copper
<b>Cr</b>	verchromt / chrome-plated
<b>EPP</b>	EPP Kunststoff / EPP plastic
<b>HDPE</b>	HDPE Kunststoff / HDPE plastic
<b>HPVC</b>	HPVC Polymer / HPVC polymer
<b>LDPE</b>	LDPE Kunststoff / LDPE plastic
<b>MF</b>	Melamin / Melamine
<b>PA</b>	Polyamid / Polyamide
<b>PC</b>	Polycarbonat / Polycarbonate
<b>PCT</b>	PCTG Polycyclohexylendimethylterephthalat / PCTG Polycyclohexylenedimethylene terephthalate

<b>PE</b>	Polyethylen / Polyethylene
<b>PET</b>	PET Polyester / PET Polyester
<b>POM</b>	POM Kunststoff / POM plastic
<b>PP</b>	Polypropylen / Polypropylene
<b>PS</b>	Polystyrol / Polystyrene
<b>PTFE</b>	PTFE Polymer / PTFE polymer
<b>PVC</b>	PVC Polymer / PVC polymer
<b>SAN</b>	SAN Kunststoff / SAN plastic
<b>SI</b>	Silikon / Silicone
<b>SST</b>	Edelstahl / Stainless steel
<b>STEEL</b>	Stahl / Stahlblech Steel / Sheet steel
<b>WOOD</b>	Bambus / Holz Bamboo / Wood

## PRODUKT PIKTOGRAMME | PRODUCT PICTOGRAMS



Antihafbeschichtung /  
Non-stick coating



Backtemperatur max. 200°C /  
Baking temperature max. 200°C



Beheizbar /  
Heatable



Bruchsicher /  
Break-proof



Einfache Bedienung /  
Easy to use



Elektrisch /  
Electric



Energiesparend /  
Energy-saving



Ergonomisch /  
Ergonomic



Für Ceranfeld geeignet /  
Suitable for ceramic hob



Für Gasofen geeignet /  
Suitable for gas oven



Für Herdplatte geeignet /  
Suitable for hot plate



Für Induktion geeignet /  
Suitable for induction



Gewerbequalität /  
Commercial quality



Glaskeramik /  
Glass ceramic



Handwäsche /  
Hand wash



Hohe Isoliereigenschaften /  
High insulation properties



Lebensmittelecht /  
Food safe



Mikrowellengeeignet /  
Microwave safe



Recyclbar, ökologisch /  
Recyclable, ecological



Schnittfest /  
Cut-resistant



Schlagfest /  
Impact-resistant



Selbstmontage /  
Self-assembly



Sicherheit /  
Safety



Spedition (gesonderte Frachtkosten) /  
Forwarding agent (separate freight charges)



Sperrgut (gesonderte Frachtkosten) /  
Bulky goods (separate freight charges)



Spezialbeschichtung /  
Special coating



Spülmaschinengeeignet /  
Dishwasher safe



Stapelbar /  
Stackable



Temperaturbeständig /  
Temperature-resistant



Timerfunktion /  
Timer function



Wasserdichte Innenoberfläche /  
Waterproof inner surface



SB-fähig in Verpackung /  
Self-service in packaging

## TABELLEN PIKTOGRAMME | TABLE PICTOGRAMS

#	Artikelnummer Item number		Etagen Floors
↗ mm	Länge Length		Gewicht Weight
→ mm	Breite Width		Traglast Load capacity
↑ mm	Höhe Height		Perforiert Perforated
↓ mm	Tiefe Depth		Materialstärke Material thickness
→  mm	Außenmaß Outer dimension	 mm	Maschenweite Mesh width
 mm	Innenmaß Inner dimension		Leistung (Watt) Power (Watt)
↔ mm	Abmessungen Dimensions		Spannung (Volt) Voltage (Volt)
↖ ↗ mm	Diverse Maße Various dimensions		Umdrehungen pro Minute Rotations per minute
∅ mm	Durchmesser Diameter	°C	Temperatur Temperature
↑ ∅ mm	Oberer Durchmesser Upper diameter		Menge pro Paket Quantity per package
↓ ∅ mm	Unterer Durchmesser Bottom diameter		Verpackungseinheit Packing unit
	Inhalt / Volumen Content / Volume		

### HACCP KENNZEICHNUNG Verwendungsgebiet

● schwarz black	Allgemein General
○ weiss white	Backwaren & Milchprodukte Baked goods & dairy products
● blau blue	Roher Fisch & Krustentiere Raw fish & shellfishes
● rot red	Rohes Fleisch Raw meat

### HACCP COLOR CODING Area of use

● gelb yellow	Geflügel Poultry
● grün green	Salat, Obst & Gemüse Salad, fruit & vegetables
● braun brown	Gekochte Lebensmittel / Wurzelgemüse Cooked food / root vegetables
● violett purple	Halal-Verarbeitung, vegan & allergenfrei Halal processing, vegan & allergen free

Länge / Length

Millimeter / Millimeters (mm)	Zentimeter / Centimeters (cm)	Inches (ins)
3	0,3	1/8
6,25	0,62	1/4
12,5	1,25	1/2
25	2,5	1
50	5	2
75	7,5	3
100	10	4
150	15	6
200	20	8
250	25	10
300	30	12
350	35	14
400	40	16
450	45	18
500	50	20
550	55	22
600	60	24
650	65	26
700	70	28
750	75	30
800	80	32
850	85	34
900	90	36
950	95	38
1000	100	40

Gewicht / Weight

Gramm / Metric grams (g)	Kilogramm / Kilogram (kg)	Masse / imperial Ounces (oz)	/ imperial pounds (lb)
25	0,25	1	
50	0,5	2	
75	0,75	3	
100	0,1	4	1/4
125	0,125	-5	
150	0,15	+5	
175	0,175	6	
200	0,2	7	
225	0,225	8	1/2
250	0,25	9	
275	0,275	10	
300	0,3	11	
325	0,325	12	3/4
350	0,35	+12	
375	0,375	13	
400	0,4	14	
425	0,425	15	
450	0,45	16	1
675	0,675	22	1,5
1000	1,0	35	2,2
1500	1,5	53	3,3
2000	2,0	71	4,4
2500	2,5	88	5,5
3000	3,0	106	6,6
3500	3,5	123	7,7

Volume

Metrik / Metric (ml/l)	Unzen / Imperial Fluid Ounces (fioz)	Imperial Pints	Unzen / US Fluid Ounces	US Pints
30 ml	1		1.01	
60 ml	2		2.02	
90 ml	3		3.04	
120 ml	4		4.05	1/4 US pt
150 ml	5	1/4 pt	5.07	
180 ml	6		6.09	
210 ml	7		7.1	
240 ml	8		8.12	1/2 US pt
270 ml	9		9.13	
300 ml	10	1/2 pt	10.14	
330 ml	11		11.16	
360 ml	12		12.17	3/4 US pt
390 ml	13		13.2	
420 ml	14		14.2	
450 ml	15	3/4 pt	15.21	
480 ml	16		16.23	1 US pt
600 ml	20	1 pt	20.28	
960 ml	32		32.46	2 US pt
1 L	35		33.81	2.1 US pt
1.1 L	40	2 pt	37.17	2.32 US pt
5 L	176	8.8 pt	169.07	10.56 US pt
6 L	211	10.56 pt	202.88	12.68 US pt
7 L	246	12.31 pt	236.7	14.75 US pt
8 L	282	14.1 pt	270.51	16.8 US pt
10 L	352	17.6 pt	338.14	21.1 US pt

Temperatur / Temperature

°C	°F
-40	-40
-30	-22
-20	-4
-10	14
0	32
10	50
20	68
30	86
40	104
50	122
60	140
70	158
80	176
90	194
100	212
110	230
120	248
130	266
140	284
150	302
160	320
170	338
180	356
190	374
200	392

## **D**

Unsere Preise verstehen sich zuzüglich der gesetzlichen Mehrwertsteuer. Es gelten unsere allgemeinen Verkaufs-, Lieferungs- und Zahlungsbedingungen.

Alle Texte, Preise und Abbildungen sind ohne Gewähr. Technische Änderungen und Modelländerungen (Online und Print) können ohne vorherige Bekanntmachung vorgenommen werden.

Irrtümer, Fehler sowie Verfügbarkeit vorbehalten. Abmessungen, Inhalte, Volumen und Gewichte sind Circa-Angaben und beziehen sich in der Regel auf randvolle Befüllung. Die Vervielfältigung dieses Kataloges (Online und Print), auch wenn partiell, ist ohne unsere ausdrückliche schriftliche Erlaubnis untersagt.

## **EN**

Our prices exclude Value Added Tax ("VAT"). Our general terms of sale, delivery and payment apply. All texts, prices and illustrations are not binding. We reserve the right to modify the technical characteristics and articles in the catalogue (online and printed) without prior notice. We decline any responsibility for any errors and/or inaccuracies. Availability subject to change. Dimensions, contents, volumes and weights are approximate and usually refer to filling to the brim. Any reproduction of this catalogue (online or print), in whole or in part, is strictly prohibited without our express written consent.

## **IT**

I nostri prezzi si intendono al netto dell'IVA. Si applicano le nostre condizioni generali di vendita, consegna e pagamento. I testi, i prezzi e le illustrazioni non sono vincolanti. Si riserva la facoltà di modificare le caratteristiche tecniche e gli articoli presenti sul catalogo (online e cartaceo) senza preavviso. Si declina ogni responsabilità per eventuali errori e/o imprecisioni. Disponibilità con riserva. Dimensioni, contenuti, volumi e pesi sono approssimativi e di norma si riferiscono al riempimento fino all'orlo. La riproduzione di questo catalogo (online e cartaceo), anche parziale, è vietata senza la nostra esplicita autorizzazione scritta.

## **ES**

Nuestros precios no incluyen IVA. Se aplican nuestras condiciones generales de venta, entrega y pago. Los precios, las descripciones e ilustraciones de los productos no son vinculantes. Nos reservamos el derecho de modificar las características técnicas y los artículos del catálogo (online e impreso) sin previo aviso. Declinamos toda responsabilidad por cualquier error y/o inexactitud. Disponibilidad con reserva. Las dimensiones, el contenido, los volúmenes y los pesos son aproximados y suelen referirse al llenado hasta el borde. La reproducción de este catálogo (online o impreso), total o parcialmente, está prohibida sin nuestro consentimiento expreso por escrito.



Offizieller Unterstützer  
der Deutschen  
Bäckernationalmannschaft

## **Schneider GmbH**

In der Längerts 1  
73095 Albershausen  
GERMANY

☎ +49 (0) 71 61 / 3004 - 0  
info@schneider-gmbh.com

**[www.schneider-gmbh.com](http://www.schneider-gmbh.com)**

