

2025/26

# PROFESSIONAL REFRIGERATION

Gamma completa di articoli  
per la refrigerazione professionale



# Guida alla Lettura

READING GUIDE  
GUIDE DE LECTURE  
LESEHILFE

IT

Fimar Group è lieta di presentare una nuova edizione del catalistino dedicato al mondo della refrigerazione!  
Un catalogo unico che unisce il brand Forcar Refrigeration con articoli in acciaio inox AISI 304 e Forcold con acciaio inox prevalentemente AISI 201. All'interno troverete due linee a confronto che si differenziano solamente per il tipo di acciaio utilizzato e per il prezzo.

Ritroveremo armadi e tavoli refrigerati con sistema monoblocco per la linea Forcold e tante novità come i tavoli Refrigerati con lavello, le cassettiere refrigerate su ruote, nuove vetrine espositive ed utili retro banchi bar. La linea di fabbricatori di ghiaccio si è rinnovata con display digitale e nuove funzionalità e nella linea Premium sono stati aggiunti degli armadi refrigerati per griglie GN1/1 con guide stampate, il tutto all'insegna della massima igiene.

Fimar Group non si ferma mai!

EN

The Fimar Group is pleased to present a new edition of its catalogue dedicated to the world of refrigeration!  
This unique catalogue combines the Forcar Refrigeration brand with AISI 304 stainless steel items, and the Forcold brand with AISI 201 stainless steel items. The two lines differ only in the type of steel used and the price.

The Forcold line includes refrigerated cabinets and tables with a monobloc system, as well as many new features, such as refrigerated tables with sinks, refrigerated drawers on wheels, new display cases, and useful bar counters.  
The ice maker line has been updated with digital displays and new features, while the Premium line now includes refrigerated cabinets for GN1/1 grids with moulded slides - all of which are designed with maximum hygiene in mind.

Fimar Group never stops!



Cerca il bollino novità e scopri le tutte!

Look for the new sticker and discover them all!

Cherchez la vignette de la nouveauté et découvrez-les tous!

Achten sie auf den neuheitsaufkleber und entdecken sie sie alle!

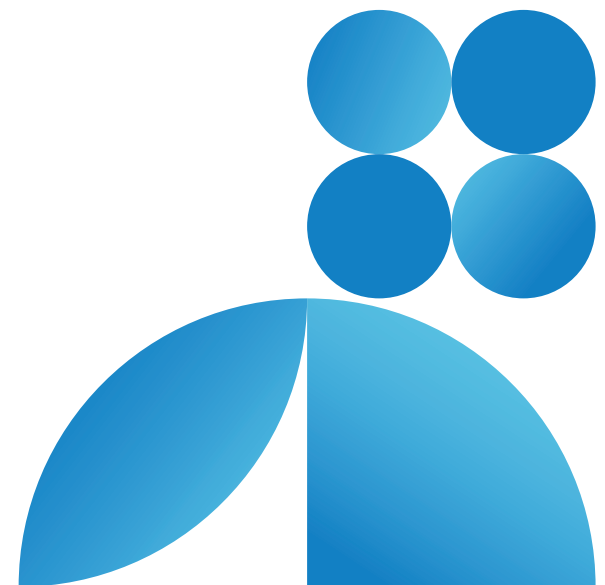

FR

Fimar Group est heureux de présenter une nouvelle édition de son catalogue dédié au monde de la réfrigération! Ce catalogue unique réunit les marques Forcar Refrigeration, avec des articles en acier Inox AISI 304, et Forcold, avec des articles en acier Inox principalement AISI 201. Vous y trouverez deux gammes comparables qui ne diffèrent que par le type d'acier utilisé et le prix.

Vous y trouverez des armoires et des tables réfrigérées à système monobloc pour la gamme Forcold, ainsi que de nombreuses nouveautés: tables réfrigérées avec évier, tiroirs réfrigérés sur roues, nouvelles vitrines d'exposition et pratiques comptoirs de bar.

La gamme de machines à glaçons a été renouvelée avec un affichage numérique et de nouvelles fonctionnalités, et la gamme Premium s'est enrichie d'armoires réfrigérées pour grilles GN1/1 avec glissières moulées, pour une hygiène optimale.

Fimar Group ne s'arrête jamais!

DE

Die Fimar Group freut sich, eine neue Ausgabe des Katalogs für die Welt der Kältetechnik vorstellen zu dürfen! Ein einzigartiger Katalog, der die Marke Forcar Refrigeration mit Artikeln aus Edelstahl AISI 304 und Forcold mit Edelstahl, hauptsächlich AISI 201, vereint. Im Katalog finden Sie zwei Produktlinien im Vergleich, die sich nur durch die Art des verwendeten Stahls und den Preis unterscheiden.

Wir finden Kühlschränke und -tische mit Monoblock-System für die Produktlinie Forcold und viele Neuheiten wie Kühlische mit Spüle, Kühl Schubladen auf Rädern, neue Vitrinen und nützliche Bar-Theken. Die Eismaschinen-Linie wurde mit einem digitalen Display und neuen Funktionen überarbeitet, und die Premium-Linie wurde um Kühlschränke für GN1/1-Gitter mit geformten Führungen erweitert, die alle höchsten Hygienestandards entsprechen.

Die Fimar Group ist niemals müde!



# Etichette energetiche

ENERGY LABELS  
ÉTIQUETTES ÉNERGÉTIQUES  
ENERGIE-ETIKETTEN

IT All'interno del catalogo Fimar Group dedicato al mondo della refrigerazione troverete 5 tipi di etichette energetiche che rispondono alle attuali normative. Da marzo 2021, l'Unione Europea ha introdotto nuove etichette energetiche che passano da un sistema di etichettatura basato su una scala da A+++ a G; ad una precedente scala più semplice che va da A a G. È quindi così possibile che un prodotto classificato seguendo le vecchie normative in classe A, oggi si trovi in classe F senza però variare il livello di efficienza dell'apparecchio. La diversa classificazione deriva dalla novità delle formule, dai parametri e dagli intervalli di valori utilizzati, ma non comporta nessun cambiamento in termini di efficienza del prodotto stesso. Nel settore professionale al momento della pubblicazione di questo catalogo, convivono etichette del nuovo modello identificabili da un QR-Code ed etichette del vecchio modello. Inquadrando il QR-Code con un dispositivo online, si accede ad un database europeo di prodotti per l'etichettatura energetica. A titolo esemplificativo riportiamo alcune nostre etichette energetiche con relativo regolamento ed applicazione di prodotto. Per maggiori informazioni su come leggere le etichette energetiche si prega di approfondire il testo ufficiale secondo la normativa applicabile.

FR Within the Fimar Group's catalogue dedicated to the world of refrigeration, you will find 5 types of energy labels that comply with current regulations. As of March 2021, the European Union has introduced new energy labels, moving from a labelling system based on a scale of A++ to G, back to the previous simpler scale of A to G. It is thus possible that a product classified according to the old regulations in class A, is now in class F without changing the efficiency level of the appliance. The different classification results from the novelty of the formulas, parameters and value ranges used, but does not lead to any change in the efficiency of the product itself. In the professional sector at the time of publication of this catalogue, labels of the new model identifiable by a QR-Code and labels of the old model coexist. Framing the QR-Code with an online device gives access to a European database of energy labelling products. As an example, here are some of our energy labels with the relevant product regulation and application. For more information on how to read energy labels, please refer to the official text according to the applicable regulation.

## REG. 2019/2016

Apparecchi di refrigerazione  
Refrigeration equipment

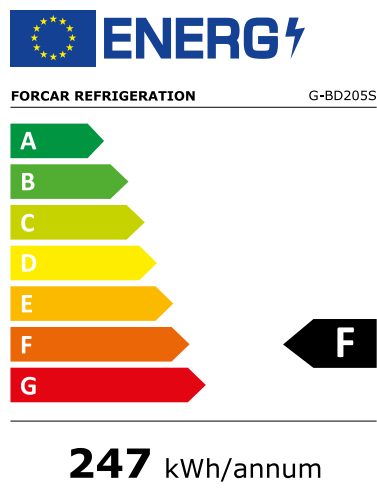

## REG. 2019/2018

Apparecchi di refrigerazione vendita diretta  
Refrigeration appliances direct sales

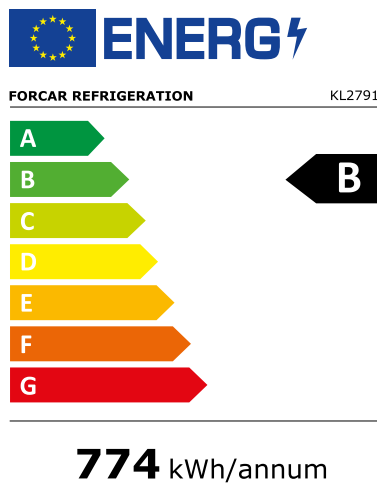

## REG. 2019/2016

Frigoriferi cantina  
Cellar refrigerators

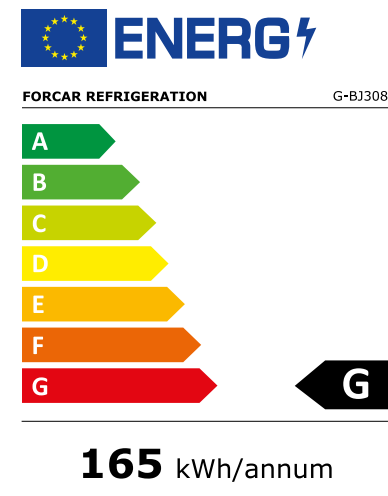

EN Dans le catalogue Fimar Group dédié au monde de la réfrigération, vous trouverez 5 types d'étiquettes énergétiques conformes à la réglementation en vigueur. À partir de mars 2021, l'Union européenne a introduit de nouvelles étiquettes énergétiques, passant d'un système d'étiquetage basé sur une échelle de A++ à G, à l'ancienne échelle plus simple de A à G. Il est donc possible qu'un produit classé selon l'ancienne réglementation dans la classe A, soit maintenant dans la classe F sans changer le niveau d'efficacité de l'appareil. La différence de classification résulte de la nouveauté des formules, des paramètres et des plages de valeurs utilisés, mais n'entraîne aucune modification de l'efficacité du produit lui-même. Dans le secteur professionnel au moment de la publication de ce catalogue, les étiquettes du nouveau modèle identifiables par un QR-Code et les étiquettes de l'ancien modèle coexistent. L'encadrement du QR-Code par un dispositif en ligne permet d'accéder à une base de données européenne de produits étiquetés en matière d'énergie. À titre d'exemple, voici quelques-unes de nos étiquettes énergétiques accompagnées de la réglementation et de l'application du produit concerné. Pour plus d'informations sur la manière de lire les étiquettes énergétiques, veuillez vous référer au texte officiel conformément à la réglementation applicable.

DE Im Katalog der Fimar Group, der der Welt der Kältetechnik gewidmet ist, finden Sie 5 Arten von Energieetiketten, die den geltenden Vorschriften entsprechen. Ab März 2021 führt die Europäische Union neue Energieetiketten ein und kehrt von einem Kennzeichnungssystem, das auf einer Skala von A++ bis G basiert, zu der früheren, einfacheren Skala von A bis G zurück. Es ist also möglich, dass ein Produkt, das nach den alten Vorschriften in die Klasse A eingestuft wurde, jetzt in die Klasse F fällt, ohne dass sich der Wirkungsgrad des Geräts ändert. Die unterschiedliche Einstufung ergibt sich aus der Neuartigkeit der verwendeten Formeln, Parameter und Wertebereiche, führt aber nicht zu einer Veränderung der Effizienz des Produktes selbst. Im Fachhandel bestehen zum Zeitpunkt der Veröffentlichung dieses Katalogs Etiketten des neuen Modells, die durch einen QR-Code erkennbar sind, und Etiketten des alten Modells gleichzeitig. Die Eingabe des QR-Codes in ein Online-Gerät ermöglicht den Zugriff auf eine europäische Datenbank mit Energieetiketten. Als Beispiel finden Sie hier einige unserer Energieetiketten mit den entsprechenden Produktvorschriften und Anwendungen. Für weitere Informationen über das Lesen von Energieetiketten sehen Sie sich bitte den offiziellen Text gemäß der geltenden Verordnung an.

#### REG. 2019/2018

Refrigeratori per bevande  
Beverage coolers

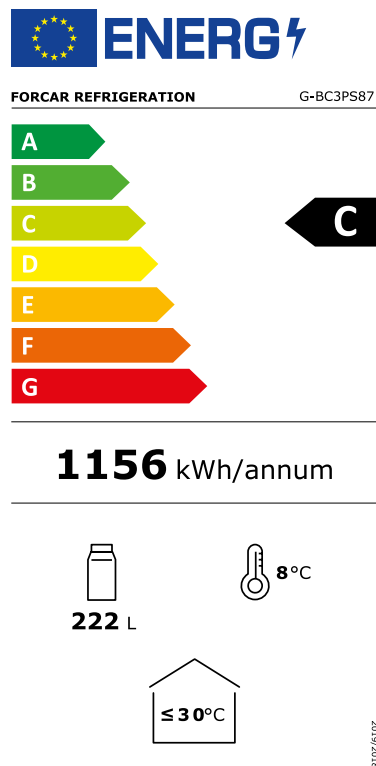

#### REG. 2015/1094

Refrigerazione professionale  
Professional refrigeration

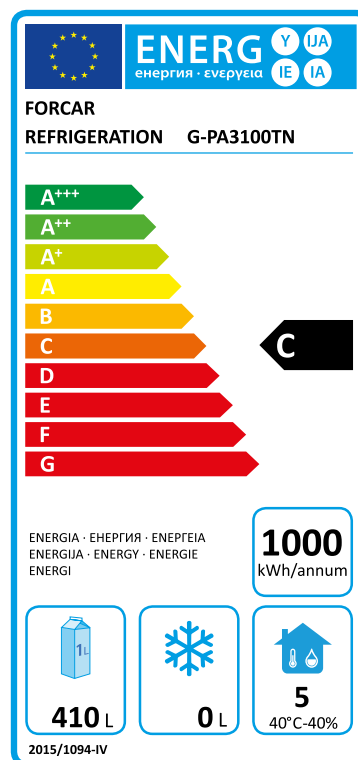

**GWP**  
Global Warming Potential

Num. 3

Le normative UE prevedono che lo smaltimento dei prodotti di refrigerazione sia eseguito da aziende specializzate nella rimozione o nel riciclaggio di tutti i gas e dei componenti in metallo e plastica.

EU regulations require that every refrigeration product is disposed of by companies specialised in removing and/or recycling all gasses, metal and plastic components.

Les règlements de l'UE exigent que les produits munis de réfrigérants soient mis au rebut par des entreprises spécialisées, équipées pour extraire et recycler les composants à gaz, métalliques et en plastique.

Gemäß EU-Vorschriften müssen Kühlprodukte von Fachunternehmen entsorgt werden, die alle Gase, Metall- und Kunststoffbauteile entfernen oder recyceln.

# Consigli sulla pulizia e la cura di macchinari in acciaio inox

IT

Una corretta pulizia e manutenzione dell'acciaio inox su apparecchiature professionali contribuirà a mantenere il macchinario efficiente e in ottime condizioni di igiene garantendone un prolungato utilizzo.

L'acciaio inossidabile (o inox) è così chiamato per la sua alta resistenza alla corrosione; tuttavia il sottile strato protettivo che riveste il metallo, può essere danneggiato meccanicamente o chimicamente (ad esempio con graffi, incisioni, tagli o l'utilizzo di prodotti corrosivi vedi tabella di seguito).

Alcuni suggerimenti per mantenere inalterato l'acciaio inox:

1. Utilizza una soluzione di detergente delicato mescolando acqua tiepida e un detergente neutro. Evita di utilizzare detergenti aggressivi o abrasivi, in quanto potrebbero danneggiare la superficie in acciaio inox.
2. Immergi un panno morbido o una spugna nella soluzione detergente e pulisci delicatamente la superficie dell'acciaio inox. Assicurati di seguire il grano dell'acciaio inox per evitare graffi sulla superficie.
3. Per le zone più ostinate o per eventuali macchie, puoi utilizzare un detergente specifico per l'acciaio inox ad uso alimentare (vedi la sezione dedicata alla pulizia delle macchine sul catalogo Fimar).
4. Dopo aver rimosso lo sporco, risciacqua bene il macchinario con acqua pulita per eliminare completamente i residui del detergente.
5. Asciuga la superficie con un panno pulito e asciutto per evitare la formazione di macchie d'acqua.
6. Oltre alla pulizia regolare, è consigliabile effettuare una manutenzione periodica sulla macchina refrigerante per assicurarsi che funzioni in modo ottimale. Controlla i filtri, le guarnizioni e le condizioni generali del macchinario.
7. Durante la pulizia, presta attenzione a non danneggiare le parti elettriche o meccaniche del macchinario. Si consiglia di consultare sempre un tecnico specializzato o un servizio di manutenzione autorizzato.

EN

Proper cleaning and maintenance of stainless steel on professional equipment will help to keep the machinery efficient and in excellent hygienic condition and ensure its continued use.

Stainless steel is named for its high resistance to corrosion; however, the thin protective layer that covers the metal can be damaged mechanically or chemically (e.g. by scratches, incisions, cuts or the use of corrosive products see table below).

Some tips for maintaining stainless steel:

1. Use a mild detergent solution by mixing warm water and a neutral detergent. Avoid using harsh or abrasive cleaners, as they may damage the stainless steel surface.
2. Dip a soft cloth or sponge into the cleaning solution and gently wipe the stainless steel surface. Be sure to follow the grain of the stainless steel to avoid scratches on the surface.
3. For stubborn areas or any stains, you can use a detergent specifically for stainless steel for food use (see the section on machine cleaning in the Fimar catalogue).
4. After removing the dirt, rinse the machine well with clean water to completely remove any residues of the detergent.
5. Dry the surface with a clean, dry cloth to prevent water spots from forming.
6. In addition to regular cleaning, it is advisable to carry out periodic maintenance on refrigerating equipment to ensure that it functions optimally. Check the filters, seals and general condition of the equipment.
7. When cleaning, take care not to damage the electrical or mechanical parts of the machine. Always consult a specialised technician or an authorised maintenance service.

## FR

Un nettoyage et un entretien adéquats de l'acier inox sur les équipements professionnels permettront de maintenir l'efficacité et l'hygiène des machines et d'assurer leur utilisation continue.

L'acier inoxydable (ou inox) est appelé ainsi en raison de sa grande résistance à la corrosion ; toutefois, la fine membrane protectrice qui recouvre le métal peut être endommagée mécaniquement ou chimiquement (par exemple, par des rayures, des incisions, des coupures ou l'utilisation de produits corrosifs - voir le tableau ci-dessous).

Quelques conseils pour l'entretien de l'acier inox:

1. Utilisez une solution détergente douce en mélangeant de l'eau tiède et un détergent neutre. Évitez d'utiliser des nettoyeurs agressifs ou abrasifs, car ils risquent d'endommager la surface de l'acier inoxydable.
2. Trempez un chiffon doux ou une éponge dans la solution de nettoyage et essuyez délicatement la surface en acier inox. Veillez à suivre le grain de l'acier inox afin d'éviter les rayures sur la surface.
3. Pour les zones tenaces ou les taches, vous pouvez utiliser un détergent spécifique pour l'acier inoxydable à usage alimentaire (voir la section sur le nettoyage des appareils dans le catalogue Fimar).
4. Après avoir éliminé la saleté, rincez bien la machine à l'eau claire pour éliminer complètement les résidus de détergent.
5. Séchez la surface avec un chiffon propre et sec pour éviter la formation de taches d'eau.
6. Outre le nettoyage régulier, il est conseillé d'effectuer un entretien périodique de la machine frigorifique pour garantir son fonctionnement optimal. Vérifiez les filtres, les joints et l'état général de la machine.
7. Lors du nettoyage, veillez à ne pas endommager les parties électriques ou mécaniques de la machine. Consultez toujours un technicien spécialisé ou un service d'entretien autorisé.

## DE

Die ordnungsgemäße Reinigung und Pflege von Edelstahl bei professionellen Geräten trägt dazu bei, die Effizienz und Hygiene der Maschinen zu erhalten und ihre weitere Nutzung zu gewährleisten.

Die dünne Schutzschicht, die das Metall bedeckt, kann jedoch mechanisch oder chemisch beschädigt werden (z. B. durch Kratzer, Einschnitte, Schnitte oder die Verwendung von ätzenden Produkten, siehe Tabelle unten).

Einige Tipps zur Pflege von Edelstahl:

1. Verwenden Sie eine milde Reinigungslösung, indem Sie lauwarmes Wasser und ein neutrales Reinigungsmittel mischen. Verwenden Sie keine scharfen oder scheuernden Reinigungsmittel, da diese die Edelstahloberfläche beschädigen können.
2. Tauchen Sie ein weiches Tuch oder einen Schwamm in die Reinigungslösung und wischen Sie die Edelstahloberfläche vorsichtig ab. Achten Sie darauf, der Textur des Edelstahls zu folgen, um Kratzer auf der Oberfläche zu vermeiden.
3. Für hartnäckige Stellen oder Flecken können Sie ein spezielles Reinigungsmittel für Edelstahl für den Lebensmittelbereich verwenden (siehe den Abschnitt über die Reinigung von Geräten im Fimar-Katalog).
4. Spülen Sie die Maschine nach dem Entfernen der Verschmutzung gut mit klarem Wasser ab, um eventuelle Rückstände des Reinigungsmittels vollständig zu entfernen.
5. Trocknen Sie die Oberfläche mit einem sauberen, trockenen Tuch ab, um die Bildung von Wasserflecken zu vermeiden.
6. Neben der regelmäßigen Reinigung ist es ratsam, die Kühlgräte regelmäßig zu warten, um einen optimalen Betrieb zu gewährleisten. Überprüfen Sie die Filter, Dichtungen und den allgemeinen Zustand der Maschine.
7. Achten Sie bei der Reinigung darauf, dass die elektrischen oder mechanischen Teile der Maschine nicht beschädigt werden. Wenden Sie sich immer an einen Fachtechniker oder einen anerkannten Wartungsdienst.

# Sostanze nocive



SCHEMA RIASSUNTIVO DI REAZIONE DELL'ACCIAIO INOX A CONTATTO DI ALCUNE SOSTANZE  
SCHEMATIC REACTION OF STAINLESS STEEL IN CONTACT WITH CERTAIN SUBSTANCES  
SCHÉMA SYNTHÉTIQUE DE LA RÉACTION DE L'ACIER INOX AU CONTACT DE CERTAINES SUBSTANCES  
ÜBERSICHTSDIAGRAMM DER REAKTION VON EDELSTAHL IN KONTAKT MIT BESTIMMTEN STOFFEN

SOSTANZA / SUBSTANCES / SUBSTANCES / SUBSTANZEN		SOSTANZA / SUBSTANCES / SUBSTANCES / SUBSTANZEN	
ACIDO CLORIDRICO (tutte le concentrazioni) HYDROCHLORIC ACID (all concentrations) ACIDE CHLORHYDRIQUE (toutes les concentrations) SALZSÄURE (alle Konzentrationen)		ALCOOL ALCOHOL ALCOOL ALKOHOL	
ACIDO FLUORIDRICO (tutte le concentrazioni) HYDROFLUORIC ACID (all concentrations) ACIDE FLUORYDRIQUE (toutes les concentrations) FLUORWASSERSTOFFSÄURE (alle Konzentrationen)		BENZINA BENZENE ESSENCE BENZIN	
ACIDO MURIATICO (cloridrico commerciale) MURIATIC ACID (commercial hydrochloric) ACIDE MURIATIQUE (acide chlorhydrique dans le commerce) CHLORWASSERSTOFF (handels bläue Salzsäure)		BICARBONATO DI SODIO (tutte le concentrazioni) SODIUM BICARBONATE (all concentrations) BICARBONATE DE SOUDE (toutes les concentrations) NATRIUMHYDROGENKARBONAT (alle Konzentrationen)	
ACIDO NITRICO fino a 10°C-80°C NITRIC ACID up to 10°C-80°C ACIDE NITRIQUE jusqu 10°C-80°C SALPETERSÄURE bis 10°C-80°C		CANDEGGINA BLEACH EAU DE JAVEL CHLORBLEICHE	
ACIDO SOLFORICO FUMANTE (oleum) 50°C FUMING SULPHURIC ACID (oleum) 50°C ACIDE SULFURIQUE FUMANT (oleum) 50°C DAMPFENDE SCHWEFELSÄURE (Oleum) 50°C		CARBONATO DI SODIO (soda solvay) fino a 20% SODIUM CARBONATE (solvay soda) up to 20% SOUDE (sel solvay) jusqu 20% NATRIUMKARBONAT (Soda) bis 20%	
ACQUARAGIA TURPENTINE WHITE SPIRIT TERPENTIN		DILUENTI (acetone, toluolo, ecc.) THINNERS (acetone, toluol, etc.) DILUANTS (acetone, toluone, etc.) VERDUNNUNGSMITTEL (Aceton, Toluolo, usw.)	



IN CONDIZIONI NORMALI DI USO NON ESISTONO PROBLEMI DI CORROSIONE  
UNDER NORMAL CONDITIONS OF USE THERE ARE NO CORROSION ISSUES  
DANS DES CONDITIONS NORMALES D'UTILISATION, IL N'Y A PAS DE PROBLÈMES DE CORROSION  
UNTER NORMALEN EINSATZBEDINGUNGEN GIBT ES KEINE KORROSIONSPROBLEME



POSSIBILITÀ DI CORROSIONE EVIDENTE, VERIFICARE ATTENTAMENTE LE CONDIZIONI DI IMPIEGO  
RISK OF CORROSION, CAREFULLY VERIFY THE CONDITIONS OF USE  
RISQUE DE CORROSION ÉVIDENT, VÉRIFIEZ SOIGNEUSEMENT LES CONDITIONS D'UTILISATION  
GEFAHR EINER DEUTLICHEN KORROSION, ÜBERPRÜFEN SIE SORGFÄLTIG DIE NUTZUNGSBEDINGUNGEN



SICURI FENOMENI CORROSIVI - NON USARE  
CERTAIN CORROSIVE REACTIONS - DO NOT USE  
CERTAINES REACTIONS CORROSIVES - NE PAS UTILISER  
BESTIMMTE KORROSIONSREAKTIONEN - NICHT VERWENDEN

SOSTANZA / SUBSTANCES /  
SUBSTANCES / SUBSTANZEN

GAS DI CLORO UMIDO  
DAMP CHLORINE GAS  
GAZ DE CHLORE HUMIDE  
FEUCHTES CHLORGAS



SAPONE  
SOAP  
SAVON  
SEIFE



SODA CAUSTICA fino a 20%  
CAUSTIC SODA up to 20%  
SOUDE CAUSTIQUE jusqu'à 20%  
ÄTZNATRON bis 20%



SOLFATO DI RAME 10%  
COPPER SULPHATE 10%  
SULFATE DE CUIVRE 10%  
KUPFERSULFAT 10%



SOLVENTI (trielina, benzolo, ecc.)  
SOLVENTS (triethylene, benzol, etc.)  
SOLVANTS (trichloroéthylène, benzene, etc.)  
LÖSUNGSMITTEL (Trichlorethylen, Benzol, usw)





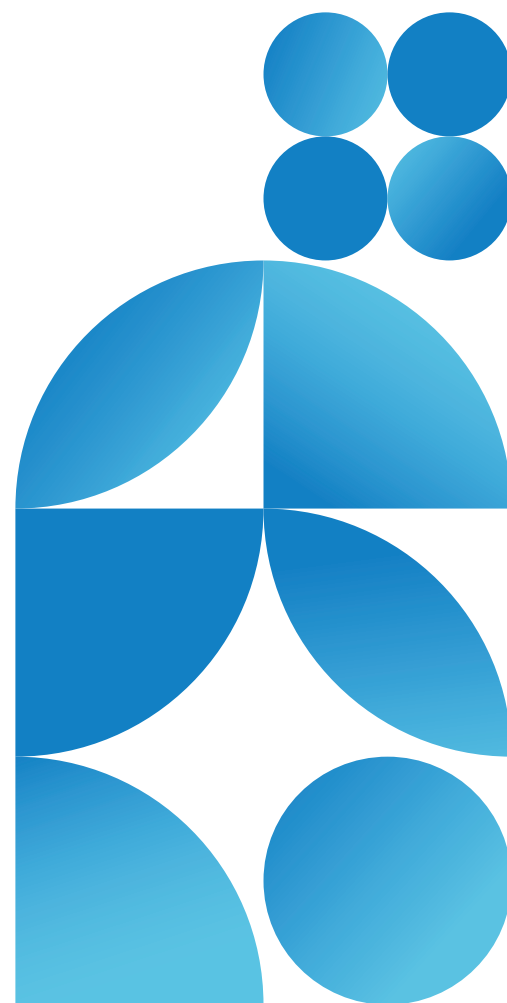













VERNICI  
PAINTS  
VERNIS  
LACKE



# Icone

ICONS  
ICÔNES  
SYMBOLE

	IT	EN	FR	DE
	TEMPERATURA DI LAVORO	OPERATING TEMPERATURE	TEMPÉRATURE DE SERVICE	BETRIEBSTEMPERATUR
	DIMENSIONI ESTERNE	EXTERNAL DIMENSIONS	DIMENSIONS EXTÉRIEURES	AUßENABMESSUNGEN
	DIMENSIONI INTERNE	INTERNAL DIMENSIONS	DIMENSIONS INTÉRIEURES	INNENABMESSUNGEN
	CAPACITÀ NOMINALE	NOMINAL CAPACITY	CAPACITÉ NOMINALE	NENNKAPAZITÄT
	TEMPERATURA MASSIMA DI LAVORO	MAX. OPERATING TEMPERATURE	TEMPÉRATURE MAXIMALE DE SERVICE	MAXIMALE BETRIEBSTEMPERATUR
	TIPO DI REFRIGERAZIONE	TYPE OF COOLING	TYPE DE REFROIDISSEMENT	KÜHLUNGSTYP
<b>DEFROST</b>	TIPO DI SBRINAMENTO	DEFROSTING TYPE	TYPE DE DÉGIVRAGE	ABTAUUNGSART
<b>GAS</b>	TIPO DI GAS REFRIGERANTE	TYPE OF COOLING GAS	GAZ RÉFRIGÉRANT	KÄLTEMITTEL
 h/Daily	PRODUZIONE ORARIA/GIORNALIERA	HOURLY/DAILY PRODUCTION	PRODUCTION HORAIRE/QUOTIDIENNE	STÜNDLICHE/TÄGLICHE PRODUKTION
	CAPACITÀ DELLA VASCA	CAPACITY OF THE BOWL	CAPACITÉ DU CONTENANT	BEHÄLTERKAPAZITÄT
 CONTROL	CONTROLLO TEMPERATURA	TEMPERATURE CONTROL	RÉGULATION DE LA TEMPÉRATURE	TEMPERATURSTEUERUNG
	ISOLAMENTO	INSULATION	ISOLATION THERMIQUE	TEMPERATURSTEUERUNG
 H <sub>2</sub> O	EVAPORAZIONE ACQUA CONDENSA	CONDENSED WATER EVAPORATION	ÉVAPORATION DE L'EAU DE CONDENSATION	KONDENSWASSERVER- DAMPFUNG

	IT	EN	FR	DE
	ASSORBIMENTO	POWER CONSUMPTION	PUISSANCE ABSORBÉE	STROMAUFNAHME
	TENSIONE	VOLTAGE	TENSION	SPANNUNG
<b>MATERIAL</b>	MATERIALE DI COSTRUZIONE	CONSTRUCTION MATERIAL	MATÉRIEL CONSTRUCTIF	BAUSTOFF
	INVERSIONE PORTA	DOOR REVERSING	INVERSION DE PORTE	TÜRUMLENKUNG
	LUCE INTERNA	INTERIOR LIGHT	ECLAIRAGE INTÉRIEUR	INNENBELEUCHTUNG
<b>STANDARD</b>	ACCESSORI IN DOTAZIONE	SUPPLIED ACCESSORIES	ACCESSOIRES FOURNIS	MITGELIEFERTE ZUBEHÖRE
<b>ENERGY CLASS</b>	CLASSE ENERGETICA	ENERGY CLASS	CLASSE ÉNERGÉTIQUE	ENERGIEKLASSE
	INFO SPEDIZIONI	DELIVERY INFO	INFORMATIONS SUR LA LIVRAISON	VERSANDINFO
	PESO NETTO	NET WEIGHT	POIDS NET	NETTOGEWICHT
	PESO LORDO	GROSS WEIGHT	POIDS BRUT	BRUTTOGEWICHT
	DIMENSIONI DI IMBALLO	PACKAGING DIMENSIONS	DIMENSIONS DES EMBALLAGES	VERPACKUNGSMASSE

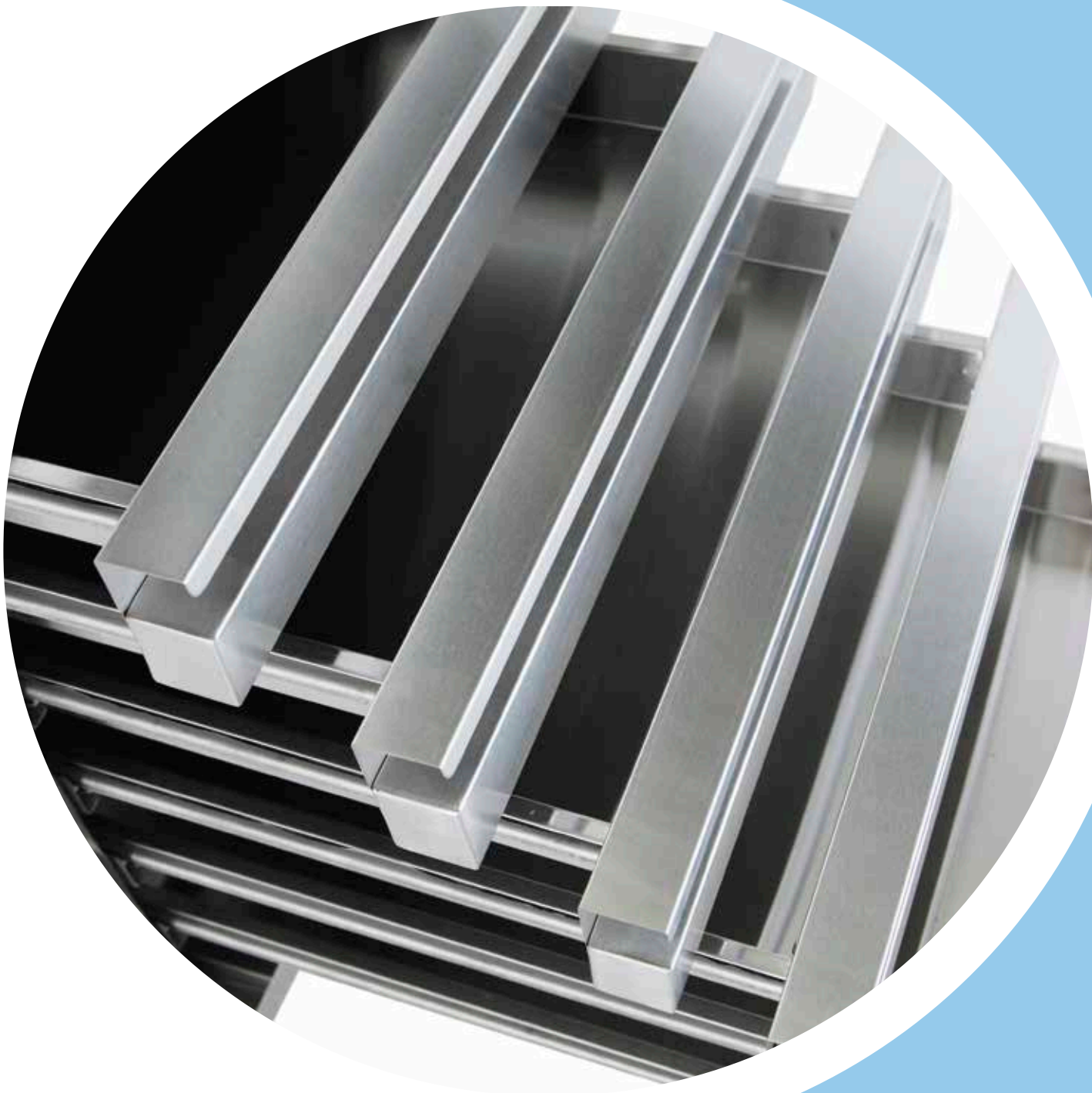

# INDICE





INDEX  
TABLE DES MATIÈRES  
INHALT

CATEGORIE	IT	EN	FR	DE	
	CONDIZIONI GENERALI DI VENDITA	GENERAL SALES CONDITIONS	CONDITIONS GÉNÉRALES DE VENTE	ALLGEMEINE VERKAUFSBEDINGUNGEN	18
PREMIUM LINE	ARMADI REFRIGERATI GN2/1 - GN1/1 VENTILATI ENERGY SAVING	REFRIGERATED CABINETS GN2/1 - GN1/1 VENTILATED ENERGY SAVING	ARMOIRES RÉFRIGÉRÉES GN2/1 - GN1/1 VENTILÉES ENERGY SAVING	GN2/1 - GN1/1 KÜHLSCHRÄNKE UMLUFTKÜHLUNG ENERGY SAVING	20
	ARMADI REFRIGERATI PER LA FROLLATURA	MEAT DRY-AGER	ARMOIRE D'AFFINAGE	REIFESCHRANK	25
	FABBRICATORI DI GHIACCIO	ICE MAKERS	MACHINES À GLACE	EISBEREITER	28
START LINE	ARMADI REFRIGERATI GN2/1 VENTILATI	REFRIGERATED CABINETS GN2/1 VENTILATED	ARMOIRES RÉFRIGÉRÉES GN2/1 VENTILÉES	GN2/1 KÜHLSCHRÄNKE UMLUFTKÜHLUNG	32
PROFESSIONAL LINE	ARMADI REFRIGERATI GN2/1 VENTILATI	REFRIGERATED CABINETS GN2/1 VENTILATED	ARMOIRES RÉFRIGÉRÉES GN2/1 VENTILÉES	GN2/1 KÜHLSCHRÄNKE UMLUFTKÜHLUNG	34
	ARMADI REFRIGERATI GN2/1 STATICI	REFRIGERATED CABINETS GN2/1 - STATIC	BASIC LINE ARMOIRES RÉFRIGÉRÉES GN2/1 STATIQUES	GN2/1 KÜHLSCHRÄNKE UMLUFTKÜHLUNG - STATISCH	46
	ARMADI REFRIGERATI STATICI - LINEA SNACK	REFRIGERATED CABINET STATIC - SNACK LINE	ARMOIRES RÉFRIGÉRÉES STATIQUES LIGNE SNACK	KÜHLSCHRÄNKE STATISCH - SERIE SNACK	53
	TAVOLI REFRIGERATI GASTRONOMIA CON LAVELLO	GASTRONOMY REFRIGERATED COUNTERS WITH SINK	TABLES RÉFRIGÉRÉES GASTRONOMIE AVEC ÉVIER	KÜHLTISCHE MIT SPÜLBECKEN	56
	TAVOLI REFRIGERATI GASTRONOMIA	GASTRONOMY REFRIGERATED COUNTERS	TABLES RÉFRIGÉRÉES GASTRONOMIE	GASTRONOMIE-KÜHLTISCHE	58
	CASSETTIERE REFRIGERATE CON RUOTE	REFRIGERATED DRAWER UNITS WITH WHEELS	ÉLÉMENTS À TIROIRS RÉFRIGÉRÉS AVEC ROUES	GEKÜHLTE SCHUBLADENELEMENTE MIT RÄDERN	76
	ABBATTITORI	BLAST CHILLERS	CELLULLES DE REFROIDISSEMENT RAPIDE	SCHNELLKÜHLER	80
SWEET LINE	ARMADI REFRIGERATI PASTICCERIA - VENTILATI	REFRIGERATED PASTRY CABINETS - VENTILATED	ARMOIRES À PÂTISSERIE RÉFRIGÉRÉES - VENTILÉES	KONDITOREI KÜHLSCHRÄNKE UMLUFTKÜHLUNG	84
	TAVOLI REFRIGERATI PASTICCERIA - VENTILATI	REFRIGERATED PASTRY COUNTERS - VENTILATED	TABLES À PÂTISSERIE RÉFRIGÉRÉES - VENTILÉES	KONDITOREI KÜHLTISCHE UMLUFTKÜHLUNG	90

CATEGORIE	IT	EN	FR	DE	
FAST FOOD & PIZZA LINE	VETRINE REFRIGERATE PER SUSHI E TAPAS - STATICHE	REFRIGERATED DISPLAY CASES FOR SUSHI AND TAPAS - STATIC	VITRINES RÉFRIGÉRÉES POUR SUSHIS ET TAPAS - STATIQUES	SUSHI- UND TAPAS-KÜHLVITRINEN - STATISCHE KÜHLUNG	96
	VETRINE REFRIGERATE PIZZA - STATICHE	REFRIGERATED PIZZA DISPLAY CASES - STATIC	VITRINES RÉFRIGÉRÉES À PIZZA - STATIQUES	PIZZA-KÜHLVITRINEN MIT DECKEL - STATISCHE KÜHLUNG	102
	VETRINE REFRIGERATE PIZZA STATICHE CON COPERCHIO	REFRIGERATED PIZZA DISPLAY CASES STATIC WITH LID	VITRINES RÉFRIGÉRÉES À PIZZA STATIQUES AVEC COUVERCLE	PIZZA-KÜHLVITRINEN STATISCHE KÜHLUNG MIT DECKEL	110
	BANCHI PIZZA REFRIGERATI VENTILATI	REFRIGERATED PIZZA COUNTERS - VENTILATED	COMPTOIRS À PIZZA RÉFRIGÉRÉS - VENTILÉS	PIZZAKÜHLTISCHE UMLUFTKÜHLUNG	115
	BANCHI PIZZA REFRIGERATI STATICI	REFRIGERATED PIZZA COUNTERS - STATIC	COMPTOIRS À PIZZA RÉFRIGÉRÉS - STATIQUES	PIZZAKÜHLTISCHE STATISCH	121
	SALADETTE REFRIGERATE PER INSALATE - STATICHE	REFRIGERATED SALADETTES FOR SALADS - STATIC	SALADETTES RÉFRIGÉRÉES POUR SALADES - STATIQUES	GEKÜHLTE SALADETTE FÜR SALATE - STATISCH	126
ECO LINE	ARMADI REFRIGERATI VENTILATI	REFRIGERATED CABINETS VENTILATED	ARMOIRES RÉFRIGÉRÉES VENTILÉES	KÜHLSCHRÄNKE UMLUFTKÜHLUNG	140
	ARMADI REFRIGERATI STATICI	REFRIGERATED CABINETS STATIC	ARMOIRES RÉFRIGÉRÉES STATIQUES	KÜHLSCHRÄNKE STATISCHE KÜHLUNG	146
	ARMADI REFRIGERATI GN2/1 - STATICI	REFRIGERATED CABINETS STATIC - GN2/1	ARMOIRES RÉFRIGÉRÉES STATIQUES - GN2/1	KÜHLSCHRÄNKE - STATISCHE KÜHLUNG - GN2/1	155
	CONGELATORI A POZZETTO	DEEP-FREEZERS	CONGÉLATEURS COFFRES	GEFRIERTRUHEN	158
GLASS & DISPLAY	VETRINE 4 LATI ESPOSITIVI REFRIGERATE	4-SIDES REFRIGERATED DISPLAY WINDOWS	VITRINES RÉFRIGÉRÉES 4 FACES	KÜHLVITRINE MIT 4 AUSSTELLUNGSSEITEN	162
	VETRINETTE ESPOSITIVE REFRIGERATE - VENTILATE	REFRIGERATED DISPLAY WINDOWS - VENTILATED	VITRINES RÉFRIGÉRÉES VENTILÉE	AUFSATKÜHLVITRINEN UMLUFTKÜHLUNG	172
	ESPOSITORI REFRIGERATI	REFRIGERATED DISPLAY CASES	PRÉSENTOIRS RÉFRIGÉRÉS	KÜHLVITRINEN	174
	ESPOSITORI IN LEGNO REFRIGERATI	REFRIGERATED WOOD DISPLAYS CASES	PRÉSENTOIRS RÉFRIGÉRÉS EN BOIS	HOLZKÜHLVITRINEN	181
	CANTINETTE VINI REFRIGERATE VENTILATE - MODELLO ENOLO	REFRIGERATED WINE CELLARS VENTILATED - ENOLO MODEL	CAVES À VIN RÉFRIGÉRÉES VENTILÉES - LIGNE ENOLO	GEKÜHLTE WEINKELLER UMLUFTKÜHLUNG MODELLO ENOLO	187
	CANTINETTE VINI REFRIGERATE STATICHE - MODELLO BJ	REFRIGERATED WINE CELLARS STATICS - MODEL BJ	CAVE À VINS RÉFRIGÉRÉES STATIQUES - MODÉL BJ	GEKÜHLTE WEINKELLER STATISCH - MODELLO BJ	191
	ARMADI REFRIGERATI LINEA SNACK - VENTILATI	SNACK REFRIGERATED CABINETS VENTILATED	ARMOIRES RÉFRIGÉRÉES LIGNE SNACK - VENTILÉES	KÜHLSCHRÄNKE UMLUFTKÜHLUNG SNACK-LINIE	194
	ARMADI REFRIGERATI LINEA SNACK - STATICI	SNACK REFRIGERATED CABINETS STATICS	ARMOIRES RÉFRIGÉRÉES LIGNE SNACK - STATIQUES	KÜHLSCHRÄNKE - STATISCHE KÜHLUNG - SNACK LINE	198
BOTTLE COOLER	BOTTLE COOLER	REFROIDISSEUR DE BOUTEILLE	FLASCHENKÜHLER	204	
RETRO BANCHI BAR	BAR COUNTER BACKS	COMPTOIRS DE BAR	RETRO-THEKEN	210	

# Indice

CODICE	
ARC100B	177
ARC400RC	177
CAS7	114
CAS7-FC	114
G-AB1203	82
G-AB1805	82
G-AB4010	83
G-AB5514	83
G-BC1PB	208
G-BC1PB87	209
G-BC2PS	208
G-BC2PS87	209
G-BC300BPB	205
G-BC3PS	208
G-BC3PS87	209
G-BC500BPB	205
G-BC500BPS	205
G-BD205S	159
G-BD305S	159
G-BD350S	159
G-BD450S	160
G-BD550S	160
G-BD650S	160
G-BJ118	192
G-BJ208	192
G-BJ308	193
G-BJ408	193
G-CBR12	 77
G-CBR13	 78

CODICE	
G-CBR22	 77
G-CBR23	 78
G-D5A	81
G-DC210	 211
G-DC310	 211
G-EF200	147
G-EF200G	151
G-EF200GSS	151
G-EF200SS	147
G-EF400	148
G-EF400G	152
G-EF400GB	207
G-EF400GSS	152
G-EF400SS	148
G-EF600	149
G-EF600CAS	150
G-EF600G	153
G-EF600GSS	153
G-EF600SS	149
G-EF600SSCAS	150
G-EFV400	142
G-EFV400G	144
G-EFV400GSS	144
G-EFV400SS	142
G-EFV600	143
G-EFV600G	145
G-EFV600GSS	145
G-EFV600SS	143
G-ER200	147

CODICE	
G-ER200G	151
G-ER200GB	206
G-ER200GSS	151
G-ER200SS	147
G-ER400	148
G-ER400G	152
G-ER400GB	207
G-ER400GSS	152
G-ER400SS	148
G-ER500P	154
G-ER500PSS	154
G-ER600	149
G-ER600G	153
G-ER600GSS	153
G-ER600SS	149
G-ERV400	142
G-ERV400G	144
G-ERV400GSS	144
G-ERV400SS	142
G-ERV600	143
G-ERV600G	145
G-ERV600GSS	145
G-ERV600SS	143
G-GDMA120N	26
G-GDMA180N	26
G-GDPH508C	27
G-GE800BT	88
G-GN1200BT	50
G-GN1200BT-FC	51

CODICE	
G-GN1200DT	52
G-GN1200TN	50
G-GN1200TN-FC	51
G-GN1410BT	40
G-GN1410TN	40
G-GN1410TNG	42
G-GN2100BT	60
G-GN2100TN	60
G-GN2100TNG	68
G-GN2200BT	64
G-GN2200TN	64
G-GN2200TNG	68
G-GN3100BT	61
G-GN3100TN	61
G-GN3100TNG	69
G-GN3200BT	65
G-GN3200TN	65
G-GN3200TNG	69
G-GN4100BT	61
G-GN4100TN	61
G-GN4100TNG	69
G-GN4200BT	65
G-GN4200TN	65
G-GN4200TNG	69
G-GN600BT	48
G-GN600BT-FC	49
G-GN600FISH	47
G-GN600TN	48
G-GN600TN-FC	49

CODICE	
G-GN650BT	36
G-GN650BT-FC	33
G-GN650BTG	38
G-GN650TN	36
G-GN650TN-FC	33
G-GN650TNG	38
G-GNB1200BT	157
G-GNB1200TN	157
G-GNB600BT	156
G-GNB600TN	156
G-GNH280BTV-FC	New 24
G-GNH280TNV-FC	New 24
G-GNS2200TN	New 57
G-GNS3200TN	New 57
G-GNV1200DT	45
G-GNV600DT	44
GH100AN	New 31
GH100WN	New 31
GH25AN	New 29
GH25WN	New 29
GH30AN	New 29
GH30WN	New 29
GH40AN	New 30
GH40WN	New 30
GH50AN	New 30
GH50WN	New 30
GH60AN	New 31
GH60WN	New 31
G-HAV111	173
G-HAV131	173
G-HAV91	173
G-HTR125F	New 179
G-HTR165F	New 179

CODICE	
G-LDC65B	166
G-LDC65LB	166
G-LSC235	168
G-LSC235B	169
G-LSC280	168
G-LSC280B	169
G-LSC65B	167
G-LSC65LB	167
G-PA1500TNGR7	91
G-PA2000TNGR7	91
G-PA2100TN	92
G-PA2100TN-FC	93
G-PA2200TN	94
G-PA2200TN-FC	95
G-PA3100TN	92
G-PA3100TN-FC	93
G-PA3200TN	94
G-PA3200TN-FC	95
G-PA800BT	86
G-PA800BT-FC	87
G-PA800TN	86
G-PA800TN-FC	87
G-PS200	132
G-PS200-FC	133
G-PS300	132
G-PS300-FC	133
G-PS900	130
G-PS900-FC	131
G-PS903	130
G-PS903-FC	131
G-PZ1610TN-FC	120
G-PZ2600TN	116
G-PZ2600TN-FC	117

CODICE	
G-PZ2610TN	118
G-PZ2610TN-FC	119
G-PZ3600TN	118
G-PZ3600TN-FC	119
G-RI12033V	103
G-RI12038V	105
G-RI14033V	103
G-RI14038V	105
G-RI15033V	103
G-RI15038V	105
G-RI18033V	103
G-RI18038V	105
G-RI20033V	103
G-RI20038V	105
G-S400	New 127
G-S900	128
G-S900-FC	129
G-S9012D-FC	139
G-S9012DS	New 138
G-S9014D-FC	139
G-S9014DS	New 138
G-S901-FC	135
G-S901S	New 134
G-S902	128
G-S902-FC	129
G-S903	128
G-S903-FC	129
G-S903PZ	121
G-S903PZCAS	123
G-S903PZCAS-FC	124
G-S903PZ-FC	122
G-S903TOP	134
G-S903TOP-FC	135

CODICE	
G-SC100G	203
G-SC50G	203
G-SD100S	161
G-SD200S	161
G-SD320PS	161
G-SNACK1220BTG	195
G-SNACK176SC	200
G-SNACK2100TN	72
G-SNACK2100TN-FC	74
G-SNACK2200TN	72
G-SNACK2200TN-FC	74
G-SNACK2515C	200
G-SNACK290SC	201
G-SNACK3100TN	73
G-SNACK3100TN-FC	75
G-SNACK3200TN	73
G-SNACK3200TN-FC	75
G-SNACK340TNG	201
G-SNACK400BT	54
G-SNACK400BT-FC	55
G-SNACK400TN	54
G-SNACK400TN-FC	55
G-SNACK4100TN	73
G-SNACK4100TN-FC	75
G-SNACK4200TN	73
G-SNACK4200TN-FC	75
G-SNACK420BTG	196
G-SNACK610BTG	195
G-SNACK638L2TNG	202
G-SNACK930BTG	197
G-SNACKBC160H	199
G-SS45BT	136
G-SSS1200	98

CODICE	
G-SSS1500	98
G-SSS1800	99
G-SSS2000	99
G-T3	81
G-TCBD68	170
G-TCBD68B	171
G-TCBD98	170
G-TCBD98B	171
G-TS1200	100
G-TS1500	100
G-TS1800	101
G-TS2000	101
G-UGN2100TN	70
G-UGN3100TN	71
G-UGN4100TN	71
G-UGN650BT	22
G-UGN650TN	22
G-VGP200R	165
G-VGP400R	165
G-VGP420BT	164
G-VGP420TN	164
G-VI120D	188
G-VI120S	188
G-VI180D	189
G-VI180S	189
G-VPR100	180
G-VPR120	180
G-VPR160	180
G-VRX1200-330	107
G-VRX1200-330SS	111
G-VRX1200-380	109
G-VRX1200-380SS	113
G-VRX1400-330	107

CODICE	
G-VRX1400-330SS	111
G-VRX1400-380	109
G-VRX1400-380SS	113
G-VRX1500-330	107
G-VRX1500-330SS	111
G-VRX1500-380	109
G-VRX1500-380SS	113
G-VRX1800-330	107
G-VRX1800-330SS	111
G-VRX1800-380	109
G-VRX1800-380SS	113
G-VRX2000-330	107
G-VRX2000-330SS	111
G-VRX2000-380	109
G-VRX2000-380SS	113
K2791CAB	182
KL2791	182
KL2791B	182
KL2791CA	182
KL2791F	183
KL2791FB	183
KL2791FCA	183
KL2791FCAB	183
KL2791FN	183
KL2791FNB	183
KL2791N	182
KL2791NB	182
KL2792	184
KL2792B	184
KL2792CA	184
KL2792CAB	184
KL2792N	184
KL2792NB	184

CODICE	
KL2793	186
KL2793B	186
KL2793CA	186
KL2793CAB	186
KL2793N	186
KL2793NB	186
KL2794	185
KL2794B	185
KL2794CA	185
KL2794CAB	185
KL2794N	185
KL2794NB	185
M-GN1410BT-FC	41
M-GN1410BTG-FC	43
M-GN1410TN-FC	41
M-GN1410TNG-FC	43
M-GN2100BT-FC	62
M-GN2100TN-FC	62
M-GN2200BT-FC	66
M-GN2200TN-FC	66
M-GN3100BT-FC	63
M-GN3100TN-FC	63
M-GN3200BT-FC	67
M-GN3200TN-FC	67
M-GN4100BT-FC	63
M-GN4100TN-FC	63
M-GN4200BT-FC	67
M-GN4200TN-FC	67
M-GN650BT-FC	37
M-GN650BTG-FC	39
M-GN650BTS-FC	23
M-GN650TN-FC	37
M-GN650TNG-FC	39

CODICE	
M-GN650TNS-FC	23
RTS180C	175
RTS200C	175



# Condizioni generali di vendita

## IT

**COSTO DELL' IMBALLO:** compreso nel prezzo per le macchine. Per ricambi ed accessori è previsto un contributo di € 8,00; cassa in legno con coperchio per piane refrattarie, il contributo è di € 54,00.

**COSTO FISSO GESTIONE ORDINI:** € 10,00 solo per ordini di importo inferiore a € 100,00.

**ORDINI:** gli ordini devono essere trasmessi esclusivamente in forma scritta; nuovi ordini o eventuali modifiche trasmesse in forma orale non verranno accettate.

**CONDIZIONI DI PAGAMENTO:** Si richiede il pagamento con bonifico bancario per: 1. Prime forniture. - 2. Al superamento del fido. - 3. Invio di ricambi.

**DILAZIONI DI PAGAMENTO:** da definire.

Sulle somme pagate in ritardo rispetto alla scadenza pattuita, saranno addebitati gli interessi di mora al tasso legale. Eventuali note di accredito saranno detratte nella fattura successiva.

**PREZZI:** non sono impegnativi, possono subire variazioni senza obbligo di preavviso, in tal caso saranno confermati all'ordine. Tutti i prezzi sono esclusi di IVA.

**TERMINI DI CONSEGNA:** 1. Per l'Italia, possibile spedizione in 24 ore per macchine disponibili a magazzino. 2. Per macchine da produrre considerare circa 25 giorni salvo imprevisti.

**TRASPORTO:** FRANCO FABBRICA, la merce viaggia a rischio e pericolo del committente, per cui Fimar S.p.a. non è responsabile per eventuali danni subiti dalla merce durante il trasporto. Eventuali contestazioni dovranno essere effettuate all'atto della consegna entro i termini di legge.

**ASSISTENZA TECNICA:** a carico del rivenditore per tutta la durata della garanzia di anni uno. Fimar S.p.a. si impegna a fornire, in garanzia, tutti i componenti di ricambio ritenuti difettosi. Il prezzo di vendita fatturato all'utilizzatore finale comprenderà non solo il prezzo dei prodotti finiti venduti, ma anche la gestione da parte del rivenditore della garanzia a copertura di essi. Fimar S.p.a. non dovrà sostenere alcuna spesa diretta o indiretta sostenuta dal rivenditore per la gestione della garanzia. La garanzia decade sul prodotto danneggiato o compromesso da un uso scorretto o comunque non conforme.

**INSTALLAZIONE:** installazione ed istruzione sull'utilizzo delle macchine e dei suoi accessori sono a carico del rivenditore.

**RIPARAZIONI:** nel caso in cui un preventivo di riparazione non venga accettato verranno addebitati € 25,00 quale concorso spese dei costi di gestione.

**GARANZIA:** 12 mesi.

**RESI:** per eventuali resi autorizzati di merce con imballo integro, sarà trattenuta una quota pari al 15% del valore, con un minimo di € 50.

**ASSICURAZIONE:** tutte le nostre macchine sono coperte da assicurazione (responsabilità civile verso terzi) Escluso U.S.A. e CANADA.

**CATALISTINO:** la presente documentazione annulla tutte le precedenti. I dati tecnici, le illustrazioni e le immagini riportate nella presente, sono puramente indicativi. La Ditta si riserva il diritto di modificare le caratteristiche tecniche ed estetiche o sospendere, in ogni momento, la propria produzione senza obbligo di preavviso.

**IMMAGINI ED ILLUSTRAZIONI:** tutte le immagini realizzate dal produttore sono coperte da copyright. L'utilizzo o la riproduzione delle medesime sono soggette ad autorizzazione da parte della Ditta proprietaria del marchio e detentrica dei diritti di proprietà materiale ed intellettuale. I prezzi o i dati tecnici potranno subire variazioni nel caso di errori tipografici o di cambiamenti in corso d'opera.

**MARCHI E BREVETTI:** è fatto espresso divieto di utilizzare i marchi e/o i brevetti registrati dalla Fimar S.p.a. Si precisa che tutti i macchinari e gli accessori non marcati CE presentano caratteristiche specifiche che non li rendono idonei alla vendita all'interno dei paesi dell'Unione Europea.

**RICHIESTA DI DOCUMENTAZIONE TECNICA AGGIUNTIVA:** Copia conforme all'originale della Certificazione CE: € 20,00 + spese di spedizione - Copia cartacea del Manuale d'Uso e Manutenzione: € 40,00 + spese di spedizione.

MOD0176V01 - FINITO DI STAMPARE NEL SETTEMBRE 2025

## EN

**PACKAGING COSTS:** included in the price for equipment. Spare parts and accessories are subject to a surcharge of €8.00. Wooden crate with lid for refractory plates is subject to a surcharge of €54.00.

**FIXED COST OF ORDER MANAGEMENT:** € 10.00 only on orders of less than € 100.00.

**ORDERS:** Orders must be transmitted in written form only; new orders or any changes transmitted in verbal form will not be accepted.

**PAYMENT TERMS:** Payment by bank transfer is required for: 1. First deliveries. - 2. On exceeding the credit limit. - 3. Shipment of spare parts.

**PAYMENT DEFERRALS:** To be defined.

Interest at the legal rate shall be charged on sums paid late with respect to the agreed due date. Any credit notes will be deducted from the next invoice.

**PRICES:** these are not binding, they may vary without prior notice, in which case they will be confirmed on the order. Prices are VAT excluded.

**DELIVERY TERMS:** 1. For Italy, possible shipment within 24 hours for machines in stock. 2. For machines to be produced, please allow approximately 25 days, barring unforeseen circumstances.

**SHIPMENT:** EX WORKS, goods travel at the customer's risk, therefore Fimar S.p.a. is not responsible for any damage suffered by the goods during transport. Any claims must be made at the time of delivery within the legal terms.

**TECHNICAL ASSISTANCE:** charged to the dealer for the entire duration of the warranty of one year. Fimar S.p.a. undertakes to supply, under warranty, all spare parts deemed defective. The sales price invoiced to the end user shall include not only the price of the finished products sold, but also the dealer's handling of the warranty covering them. Fimar S.p.a. shall not incur any direct or indirect expenses borne by the retailer for the management of the warranty. The warranty shall be void if the product is damaged or impaired by incorrect or otherwise non-compliant use.

**INSTALLATION:** installation and instruction in the use of the machine and its accessories are the responsibility of the dealer.

**REPAIRS:** in the event that a repair quote is not accepted, € 25.00 will be charged as a contribution towards operating costs.

**WARRANTY:** 12 months.

**RETURNS:** for any authorised returns of goods with undamaged packaging, a fee of 15% of the value will be withheld, with a minimum of € 50.

**INSURANCE:** all our machines are covered by insurance (third party liability) Excluding U.S.A. and CANADA.

**CATALOGUE:** this document invalidates all previous ones. The technical data, illustrations and pictures in this document are purely indicative. The Company reserves the right to modify the technical and aesthetic characteristics or discontinue its production at any time without prior notice.

**IMAGES AND ILLUSTRATIONS:** All images taken by the manufacturer are covered by copyright. Their use or reproduction is subject to authorisation by the company that owns the trademark and holds the material and intellectual property rights. Prices or technical data may be subject to change in the event of typographical errors or changes.

**TRADEMARK AND PATENTS:** It is expressly forbidden to use the trademarks and/or patents registered by Fimar S.p.a.. Please note that all machinery and accessories that are not CE marked have specific characteristics that make them unsuitable for sale within the countries of the European Union.

**REQUEST FOR ADDITIONAL TECHNICAL DOCUMENTATION:** Copy conforming to the original of the CE Certification: € 20.00 + shipping costs - Hard copy of the Use and Maintenance Manual: € 40.00 + shipping costs.

MOD0176V01 - PRINTED IN SEPTEMBER 2025

FR

**FRAIS D'EMBALLAGE:** inclus dans le prix des machines. Pour les pièces détachées et les accessoires, il faut compter une contribution de 8,00 €; pour la caisse en bois pour les plaques réfractaires avec couvercle, la contribution est de 54,00 €.

**FRAIS FIXES DE GESTION DES COMMANDES:** 10,00 € uniquement pour les commandes inférieures à 100,00 €.

**COMMANDES:** Les commandes doivent être transmises uniquement par écrit; les nouvelles commandes ou les modifications transmises oralement ne seront pas acceptées.

**CONDITIONS DE PAIEMENT:** Le paiement par virement bancaire est exigé pour: 1. les premières livraisons - 2. en cas de dépassement de la limite de crédit - 3. L'envoi de pièces détachées.

**RETARDS DE PAIEMENT:** à définir.

Les sommes payées en retard par rapport à la date d'échéance convenue sont majorées d'un intérêt au taux légal. Les avoirs éventuels seront déduits de la facture suivante.

**PRIX:** ils ne sont pas contractuels, ils peuvent varier sans préavis, auquel cas ils seront confirmés lors de la commande. Tous les prix s'entendent hors TVA.

**CONDITIONS DE LIVRAISON:** 1) Pour l'Italie, expédition possible dans les 24 heures pour les machines en stock. 2) Pour les machines à produire, il faut compter environ 25 jours, sauf imprévus.

**TRANSPORT:** EX WORKS, la marchandise voyage aux risques et périls du client, par conséquent Fimar S.p.a. n'est pas responsable des éventuels dommages subis par la marchandise pendant le transport. Toute réclamation doit être faite au moment de la livraison dans les délais légaux.

**ASSISTANCE TECHNIQUE:** à la charge du revendeur pendant toute la durée de la garantie d'un an. Fimar S.p.a. s'engage à fournir, sous garantie, toutes les pièces de rechange jugées défectueuses. Le prix de vente facturé à l'utilisateur final comprend non seulement le prix des produits finis vendus, mais aussi la prise en charge par le revendeur de la garantie qui les couvre. Fimar S.p.a. ne supportera pas les frais directs ou indirects encourus par le revendeur pour la gestion de la garantie. La garantie est annulée si le produit est endommagé ou détérioré à la suite d'une utilisation incorrecte ou non conforme.

**INSTALLATION:** l'installation et la formation à l'utilisation de l'appareil et de ses accessoires sont à la charge du revendeur.

**RÉPARATIONS:** en cas de refus d'un devis de réparation, 25,00 € seront facturés à titre de participation aux frais d'exploitation.

**GARANTIE:** 12 mois.

**RETOURS:** pour tout retour autorisé de marchandises dans un emballage intact, une retenue de 15% de la valeur sera effectuée, avec un minimum de 50 €.

**ASSURANCE:** toutes nos machines sont couvertes par une assurance (responsabilité civile), à l'exclusion des États-Unis et du Canada.

**CATALOGUE LISTE:** Ce document annule tous les documents précédents. Les données techniques, les illustrations et les photos contenues dans ce document sont purement indicatives. La société se réserve le droit de modifier les caractéristiques techniques et esthétiques ou d'arrêter la production à tout moment et sans préavis.

**IMAGES ET ILLUSTRATIONS:** Toutes les images prises par le fabricant sont couvertes par le droit d'auteur. Leur utilisation ou leur reproduction est soumise à l'autorisation de la société propriétaire de la marque et détentrice des droits matériels et de propriété intellectuelle. Les prix ou les données techniques peuvent être modifiés en cas d'erreurs typographiques ou de changements.

**MARQUES ET BREVETS:** Il est expressément interdit d'utiliser les marques et/ou les brevets déposés par Fimar S.p.a.. Il est à noter que les machines et les accessoires non marqués CE présentent des caractéristiques spécifiques qui les rendent impropres à la vente dans les pays de l'Union européenne.

**DEMANDE DE DOCUMENTATION TECHNIQUE SUPPLÉMENTAIRE:** Copie conforme à l'original de la certification CE: 20,00 € + frais d'expédition - Copie papier du manuel d'utilisation et d'entretien: 40,00 € + frais d'expédition.

MOD0176V01 - IMPRESSION TERMINÉE EN SEPTEMBRE 2025

DE

**VERPACKUNGSKOSTEN:** im Gerätepreis enthalten. Für Ersatzteile und Zubehör werden 8,00 € als Beitrag erhoben; für die Holzkiste für feuerfeste Platten mit Deckel beträgt der Beitrag 54,00 €.

**FESTE KOSTEN FÜR DIE BESTELLUNGSVERWALTUNG:** 10,00 € nur für Bestellungen unter 100,00 €.

**AUFTRÄGE:** Aufträge sind ausschließlich in schriftlicher Form zu übermitteln; mündlich übermittelte Neuaufträge oder Änderungen werden nicht angenommen.

**ZAHLUNGSBEDINGUNGEN:** Die Zahlung per Banküberweisung ist erforderlich: 1. bei der ersten Lieferung. - 2. bei Überschreitung des Kreditlimits. - 3. bei Versand von Ersatzteilen.

**ZAHLUNGSVERZÖGERUNGEN:** zu bestimmen.

Auf verspätet gezahlte Beträge werden Verzugszinsen in Höhe des gesetzlichen Zinssatzes erhoben. Eventuelle Gutschriften werden mit der nächsten Rechnung verrechnet.

**PREISE:** Sie sind unverbindlich und können ohne vorherige Ankündigung geändert werden; in diesem Fall werden sie auf der Bestellung bestätigt. Alle Preise verstehen sich ohne Mehrwertsteuer.

**LIEFERBEDINGUNGEN:** 1. für Italien, möglicher Versand innerhalb von 24 Stunden für Geräte auf Lager. 2) Für Geräte, die hergestellt werden sollen, beträgt die Lieferzeit etwa 25 Tage, sofern keine unvorhergesehenen Umstände eintreten.

**TRANSPORT:** AB WERK, die Ware reist auf Risiko des Kunden, daher ist Fimar S.p.a. nicht für eventuelle Schäden an der Ware während des Transports verantwortlich. Eventuelle Reklamationen müssen zum Zeitpunkt der Lieferung innerhalb der gesetzlichen Fristen geltend gemacht werden.

**TECHNISCHE UNTERSTÜTZUNG:** zu Lasten des Händlers für die gesamte Dauer der Garantie von einem Jahr. Fimar S.p.a. verpflichtet sich, im Rahmen der Garantie alle Ersatzteile zu liefern, die als defekt gelten. Der dem Endverbraucher in Rechnung gestellte Verkaufspreis umfasst nicht nur den Preis für die verkauften Endprodukte, sondern auch die Abwicklung der Garantie durch den Händler. Fimar S.p.a. übernimmt keine direkten oder indirekten Kosten, die dem Wiederverkäufer durch die Abwicklung der Garantie entstehen. Die Garantie erlischt, wenn das Produkt durch unsachgemäßen oder anderweitig nicht konformen Gebrauch beschädigt oder beeinträchtigt wird.

**INBETRIEBNAHME:** Die Inbetriebnahme und die Einweisung in den Gebrauch des Geräts und seines Zubehörs liegen in der Verantwortung des Händlers.

**REPARATUREN:** Falls ein Kostenvoranschlag für eine Reparatur nicht akzeptiert wird, werden 25,00 € als Beitrag zu den Betriebskosten berechnet.

**GARANTIE:** 12 Monate.

**RÜCKGABE:** Für jede genehmigte Rücksendung von Waren mit unbeschädigter Verpackung wird eine Gebühr von 15 % des Wertes einbehalten, mindestens jedoch 50 €.

**VERSICHERUNG:** Alle unsere Geräte sind versichert (Haftpflicht), ausgenommen USA und KANADA.

**KATALOG-PREISLISTE:** Dieses Dokument ersetzt alle vorherigen Dokumente. Die technischen Daten, Illustrationen und Bilder in diesem Dokument sind rein indikativ. Das Unternehmen behält sich das Recht vor, die technischen und ästhetischen Merkmale zu ändern oder die Produktion jederzeit und ohne Vorankündigung einzustellen.

**BILDER UND ILLUSTRATIONEN:** Alle vom Hersteller aufgenommenen Bilder sind urheberrechtlich geschützt. Ihre Verwendung oder Vervielfältigung unterliegt der Genehmigung des Unternehmens, das Eigentümer der Marke und Inhaber der materiellen und geistigen Eigentumsrechte ist. Preise oder technische Daten können im Falle von Druckfehlern oder Änderungen geändert werden.

**MARKEN UND PATENTE:** Es ist ausdrücklich verboten, die von Fimar S.p.a. eingetragenen Marken und/oder Patente zu verwenden. Wir weisen darauf hin, dass alle Maschinen und Zubehörteile, die nicht mit der CE-Kennzeichnung versehen sind, besondere Merkmale aufweisen, die sie für den Verkauf in den Ländern der Europäischen Union ungeeignet machen.

**ANFORDERUNG VON ZUSÄTZLICHEN TECHNISCHEM DOKUMENTEN:** Kopie, die dem Original der CE-Zertifizierung entspricht: € 20,00 + Versandkosten - Ausdruck der Bedienungs- und Wartungsanleitung: 40,00 € + Versandkosten.

MOD0176V01 - DRUCKFERTIGSTELLUNG IM SEPTEMBER 2025



Premium Line

# Armadi refrigerati

## GN2/1 - GN1/1 - Energy Saving - ventilati

**IT** Gli armadi refrigerati della linea Premium si differenziano per particolari caratteristiche quali il contenimento dei consumi energetici, dello spazio e la presenza di guide stampate per una maggiore igienicità. Gli armadi refrigerati G-UGN sono realizzati in acciaio inox AISI 304 - isolamento 100 mm - versione TN in Classe A - versione BT in Classe B - linea Energy Saving con griglie interne GN2/1 su guide stampate. Gli armadi refrigerati della linea M-GN650 di Forcold sono realizzati internamente in acciaio inox AISI 304 - dotati di unità refrigerante monoblocco protetto da lamiera in acciaio - gruppo refrigerante con sistema plug-in caratterizzato da installazione o eventuale rimozione/sostituzione facile ed immediata - motore silenzioso con griglie interne GN2/1 su guide stampate. Gli armadi refrigerati G-GNH280 di Forcold si differenziano per essere poco ingombranti, solo 448 mm di larghezza - realizzati internamente in acciaio inox AISI 304 e dotati di griglie interne GN1/1 su guide stampate.

**EN** Premium line refrigerated cabinets feature special qualities such as energy saving, space saving and the presence of pressed-in slides for improved hygiene. G-UGN line refrigerated cabinets are made of stainless steel AISI 304 - insulation 100 mm - TN version in Class A - BT version in Class B - Energy Saving line with internal GN2/1 grids on moulded slides. Forcold's M-GN650 line refrigerated cabinets are made internally of AISI 304 stainless steel - equipped with a monobloc refrigerating unit protected by steel plate - plug-in refrigerating unit with plug-in system for easy and immediate installation or eventual removal/replacement - silent motor with GN2/1 internal grids on pressed-in slides. Forcold's G-GNH280 refrigerated cabinets differ in that they are space-saving, only 448 mm wide - made internally of stainless steel AISI 304 and equipped with GN1/1 internal grids on pressed-in slides.

**FR** Les armoires réfrigérées de la ligne Premium se distinguent par des caractéristiques spéciales telles que l'économie d'énergie, l'économie d'espace et la présence de glissières moulées pour une meilleure hygiène. Les armoires réfrigérées de la ligne G-UGN sont réalisées en acier inox AISI 304 - isolation 100 mm - version TN en classe A - version BT en classe B - ligne Energy Saving avec grilles internes GN2/1 sur glissières moulées. Les armoires réfrigérées de la ligne M-GN650 de Forcold sont réalisées intérieurement en acier inox AISI 304 - équipées d'un groupe frigorifique monobloc protégé par une plaque en acier - groupe frigorifique enfichable caractérisé par une installation facile et immédiate ou par un éventuel démontage/remplacement - moteur silencieux avec des grilles internes GN2/1 sur des glissières moulées. Les armoires réfrigérées G-GNH280 de Forcold se distinguent par leur faible encombrement (448 mm de largeur seulement), leur structure interne en acier inox AISI 304 et leurs grilles internes GN1/1 sur glissières moulées.

**DE** Die Kühlschränke der Premium- Linie zeichnen sich durch besondere Merkmale wie Energieeinsparung, Platzersparnis und das Vorhandensein von eingegossenen Führungen für eine verbesserte Hygiene aus. Die Kühlschränke der Linie G-UGN sind aus Edelstahl AISI 304 - Isolierung 100 mm - Version TN in Klasse A - Version BT in Klasse B - Energy Saving line mit internen Gittern GN2/1 auf vorgeformten Führungsschienen. Die Kühlschränke der Linie M-GN650 von Forcold sind innen aus Edelstahl AISI 304 gefertigt - ausgestattet mit einer Monoblock-Kühleinheit, die durch eine Stahlplatte geschützt ist - steckerfertige Kühleinheit, die sich durch eine einfache und sofortige Installation oder einen eventuellen Ausbau/Austausch auszeichnet - geräuscharmer Motor mit internen Gittern GN2/1 auf vorgeformten Führungsschienen. Die Kühlschränke G-GNH280 von Forcold unterscheiden sich durch ihren geringen Platzbedarf von nur 448 mm Breite, sind innen aus Edelstahl AISI 304 gefertigt und mit internen Gittern GN1/1 auf vorgeformten Führungsschienen ausgestattet.

## OPTIONAL

GRP11-FC	GRP21R	GRP21-FC	RUO120	ACPED	ACPED-FC
G-GNH280TNV-BTV-FC	G-UGN650TN-BT	M-GN650TNS-FC M-GN650BTS-FC	ø 120 mm	G-UGN650TN-BT	M-GN650TNS-BTS-FC G-GNH280TNV-BTV-FC
GN1/1 530 x 333 mm	GN2/1 650 x 535 mm		Kit 4 ruote, di cui 2 con freno Set of 4 wheels, 2 with brake Jeu de 4 roues, 2 avec frein Satz mit 4 Rädern, 2 mit Bremse	Pedale apertura porta Door opening pedal Pédale d'ouverture porte Türöffnungspedal	
Griglia plastificata - Plastic coated grid - Grille plastifiée Kunststoffbeschichtetes Gitter					



ACPED

# G-UGN650TN G-UGN650BT



	G-UGN650TN	G-UGN650BT
	-2°C / +8°C	-18°C / -22°C
	740 x 875 x 2090(h) mm	
	533 x 700 x 1501(h) mm	
	560 L	
	+43°C / 60%HR	
	ventilata / ventilated	
<b>DEFROST</b>	automatico / automatic	
<b>GAS</b>	R600a	R290
	automatica / automatic	
	elettronico / electronic	
	100 mm	
	250 W	380 W
	230V / 50Hz	
<b>MATERIAL</b>	acciaio Inox / stainless steel AISI 304	
	si / yes	
	led	
<b>STANDARD</b>	3 griglie / grids GN2/1	
<b>ENERGY CLASS</b>	<b>A</b>	<b>B</b>
	110 Kg	125 Kg
	130 Kg	145 Kg
	760 x 905 x 2150(h) mm	

# M-GN650TNS-FC M-GN650BTS-FC



	M-GN650TNS-FC	M-GN650BTS-FC
	0°C / +8°C	-18°C / -22°C
	660 x 830 x 1985(h) mm	
	535 x 700 x 1400(h) mm	
	530 L	
	+35°C / 75%HR	
	ventilata / ventilated	
<b>DEFROST</b>	automatico / automatic	
<b>GAS</b>	R600a	R290
	automatica / automatic	
	elettronico / electronic	
	60 mm	
	305 W	520 W
	230V / 50Hz	
	1 Ph	
<b>MATERIAL</b>	interno in acciaio Inox AISI 304 - esterno in acciaio inox AISI 201 internal stainless steel AISI 304 - external stainless steel AISI 201	
	si / yes	
	led	
<b>STANDARD</b>	3 griglie / grids GN2/1	
<b>ENERGY CLASS</b>	<b>D</b>	<b>E</b>
	101 Kg	112 Kg
	119 Kg	127 Kg
	690 x 860 x 2050(h) mm	

**FORCOLD**  
by flmar

**MONOBLOCK**

## Premium Line

Armadi refrigerati GN2/1 - ventilati / Refrigerated cabinets GN2/1 - Ventilated  
Armoires réfrigérées GN2/1 - ventilées / GN2/1 Külschränke - Umluftkühlung

# G-GNH280TNV-FC G-GNH280BTV-FC



	G-GNH280TNV-FC	G-GNH280BTV-FC
	0°C / +8°C	-18°C / -22°C
	448 x 735 x 2100(h) mm	
	328 x 575 x 1492(h) mm	
	280 L	
	+35°C / 75%HR	
	ventilata / ventilated	
<b>DEFROST</b>	automatico / automatic	
<b>GAS</b>	R290	
	automatica / automatic	
	elettronico / electronic	
	60 mm	
	305 W	520 W
	230V / 50Hz	
<b>MATERIAL</b>	interno in acciaio Inox AISI 304 - esterno in acciaio inox AISI 201 internal stainless steel AISI 304 - external stainless steel AISI 201	
	si / yes	
	led	
<b>STANDARD</b>	3 griglie / grids GN1/1	
<b>ENERGY CLASS</b>	<b>D</b>	<b>E</b>
	85 Kg	91 Kg
	103 Kg	110 Kg
	478 x 765 x 2150(h) mm	



## Premium Line

Armadi refrigerati GN1/1 - ventilati / Refrigerated cabinets GN1/1 - Ventilated  
Armoires réfrigérées GN1/1 - ventilées / GN1/1 Kühlschränke - Umluftkühlung

# Armadi refrigerati per la frollatura Premium Line



**IT** Macchine professionali per la frollatura della carne - porta in vetro per seguire direttamente la maturazione e la frollatura dei prodotti - ambiente controllato e sicuro grazie alla lampada UV germicida - controllo costante temperatura, umidità e ventilazione garantiscono un perfetto processo di frollatura. La linea G-GDMA presenta una struttura esterna in lamiera verniciata nera - interno in ABS antibatterico - sensore apertura della porta - spia acustica per segnalazione guasti - supporto e ganci in acciaio inox AISI 304.

Il modello G-DPH508 presenta una struttura completamente in acciaio inox - porta in vetro temperato a triplo strato - luci verticali a LED - blocchi sale sul fondo per un rapido assorbimento dei liquidi conseguenti alla frollatura - supporto e ganci in acciaio inox AISI 304.

**EN** Professional machines for meat aging - glass door to directly monitor the aging and seasoning of products - controlled and safe environment thanks to the UV sterilizing lamp - constant temperature, humidity and ventilation control guarantee a perfect aging process. The G-GDMA line has an external structure in black painted sheet metal - interior in anti-bacterial ABS - door opening sensor - acoustic warning light for faults - support and hooks in stainless steel AISI 304.

The G-DPH508 model has a structure entirely made of stainless steel - door in triple-layer tempered glass - vertical LED lights - salt blocks on the bottom for rapid absorption of liquids resulting from the maturing process - support and hooks in stainless steel AISI 304.

**FR** Machines professionnelles pour la maturation de la viande - porte vitrée pour suivre directement la maturation et l'affinage des produits - environnement contrôlé et protégé grâce à la lampe UV stérilisante - température, humidité et ventilation constantes qui garantissent un parfait contrôle de la maturation. La ligne G-GDMA se caractérise par une structure externe en tôle peinte en noir - intérieur en ABS antibactérien - capteur d'ouverture de la porte - avertisseur acoustique - support et crochets en acier inox AISI 304.

Le modèle G-DPH508 a une structure entièrement en acier inox - porte en verre trempé à trois couches - lumières LED verticales - blocs de sel sur le fond pour l'absorption rapide des liquides résultant de la maturation - support et crochets en acier inox AISI 304.

**DE** Professionelle Maschinen für die Fleischreifung - Glastür zur direkten Beobachtung der Reifung und Alterung des Produkts - kontrollierte und sichere Umgebung dank der sterminziden UV-Lampe - gleichbleibende Temperatur-, Feuchtigkeits- und Lüftungs-Überwachung, die einen perfekten Reifungsprozess garantiert. Die Serie G-GDMA hat eine Außenstruktur aus schwarz lackiertem Blech - Innenraum aus antibakteriellem ABS - Türöffnungssensor - akustisches Warnlicht für Störungen - Halterung und Haken aus Edelstahl AISI 304.

Das Modell G-DPH508 hat ein Gehäuse aus Edelstahl - Tür aus dreifach gehärtetem Glas - vertikale LED-Leuchten - Salzblöcke auf dem Boden für eine schnelle Aufsaugung der beim Reifungsprozess anfallenden Flüssigkeiten - Halterung und Haken aus Edelstahl AISI 304.

## OPTIONAL

GRI508	GRPFR120180	ASTFR46120180	ASTFR508	GAFR120180	GAFR508
G-GDPH508	G-GDMA120-180	G-GDMA120-180	G-GDPH508	G-GDMA120-180	G-GDPH508
526 x 604 mm	520 x 480 mm				
Griglia Inox - Stainless steel grid Grille en acier inox - Edeltahlgitter		Asta inox - Stainless steel rod Tige en acier inox - Edeltahlstange für Kühlschrank		Gancio Inox - Stainless steel hook Crochet en acier inox - Edeltahlhaken für Kühlschrank	

# G-GDMA120N G-GDMA180N



G-GDMA180N



G-GDMA120N

	G-GDMA120N Free standing / built-in	G-GDMA180N Free standing / built-in
	+1°C / +25°C	
	595 x 710 x 1270(h) mm	595 x 710 x 1720(h) mm
	485 x 552 x 1055(h) mm	485 x 552 x 1508(h) mm
	233 L	352 L
	60% - 85% HR	
	ventilata / ventilated	
<b>DEFROST</b>	automatico / automatic	
<b>GAS</b>	R600a	
	automatica / automatic	
<b>CONTROL</b>	elettronico / electronic	
	55 mm	
	170 W	
	230V / 50Hz	
<b>MATERIAL</b>	lamiera verniciata - ABS + vetrocamera painted tin plate - ABS + insulating glass	
<b>REVERSIBLE</b>	si / yes	
	led	
<b>STANDARD</b>	3 griglie 520 x 480 mm + asta con 3 ganci / 3 grids + rod with 3 hooks	
	69 Kg	83 Kg
	81 Kg	96 Kg
	645 x 780 x 1430(h) mm	645 x 780 x 1870(h) mm

# G-GDPH508C



















ganci / hooks

SALT508

G-GDPH508C

Blocco di sale  
Salt block  
Bloc de sel  
Salzblock

	G-GDPH508C
	0°C / +25°C
	730 x 805 x 2100(h) mm
	575 x 650 x 1375(h) mm
	508 L
	70% - 90% HR
	ventilata / ventilated
<b>DEFROST</b>	automatico / automatic
<b>GAS</b>	R290
	automatica / automatic
	elettronico / electronic
	60 mm
	400 W
	230V / 50Hz
<b>MATERIAL</b>	interno in acciaio Inox AISI 304 - esterno in acciaio inox 430 internal stainless steel AISI 304 - external stainless steel 430
<b>REVERSIBLE</b>	no
	led
<b>STANDARD</b>	5 griglie / grids 526 x 604 mm + 2 aste con 2 ganci / 2 rods with hooks + blocco di sale / salt block
	
	145 Kg
	170 Kg
	835 x 930 x 2270(h) mm



## Premium Line

Armadi refrigerati per la frollatura / Meat dry-ager  
Armoire d'affinage / Reifeschrank

# Fabbricatori di ghiaccio

## cubetto pieno da 18 gr - Premium Line



IT Fabbricatori di ghiaccio a cubetto pieno da 18 gr - struttura completamente in acciaio inox. La formazione dei cubetti avviene attraverso l'aspersione d'acqua su di un evaporatore orizzontale in rame il quale, raffreddandosi, forma dei cubetti di ghiaccio ad alta densità puri e cristallini; il cubetto pieno è il più indicato per il raffreddamento prolungato di qualsiasi bevanda. Disponibili nella versione con raffreddamento ad acqua oppure ad aria. Nuovi modelli con controllo digitale.

EN 18 g solid cube ice-makers - entirely made of stainless steel. The cubes are formed by sprinkling water over a horizontal copper evaporator which, as it cools, forms pure, crystalline, high-density ice cubes; the full cube is the most suitable for prolonged cooling of any beverage. Available in water-cooled or air-cooled versions. New models with digital control panel.

FR Machines à glaçons pleins de 18 g - corps en acier inox. Les cubes sont formés par l'aspersion d'eau sur un évaporateur horizontal en cuivre qui, en se refroidissant, forme des glaçons purs, cristallins et de haute densité; le cube plein est le plus approprié pour le refroidissement prolongé de n'importe quelle boisson. Disponible en version refroidie par eau ou par air. Nouveaux modèles avec panneau de contrôle numérique.

DE 18 g Vollwürfel-Eisbereiter - komplett aus Edelstahl gefertigt. Die Würfel werden gebildet, indem Wasser über einen horizontalen Kupferverdampfer gespritzt wird, der bei der Abkühlung reine, kristalline Eiswürfel mit hoher Dichte bildet; der Vollwürfel ist am besten für eine längere Kühlung jedes Getränks geeignet. Erhältlich in wassergekühlter oder luftgekühlter Ausführung. Neue Modelle mit digitalem Bedienfeld.



# GH25AN-GH25WN GH30AN-GH30WN

New



	GH25AN - GH25WN	GH30AN - GH30WN
	330 W	530 W
	230V / 50Hz	
<b>GAS</b>	R290	
	25 Kg ⊕ 21°C - ⊖ 15°C	30 Kg ⊕ 21°C - ⊖ 15°C
	6 Kg	12 Kg
	W = Raffreddamento ad acqua - Water cooled A = Raffreddamento ad aria - Air cooled	
	elettronico / electronic	
<b>CONTROL</b>		
	365 x 520 x 600(h) mm (+0/20 mm piedini regolabili / adjustable feet)	390 x 550 x 690(h) mm (+0/20 mm piedini regolabili / adjustable feet)
	30 Kg	36,5 Kg
	35 Kg	41 Kg
	570 x 415 x 740(h) mm	600 x 440 x 830(h) mm



MADE IN ITALY

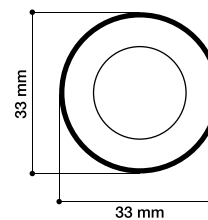
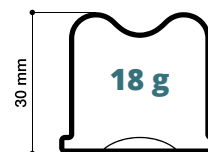

## Premium Line

Fabbricatori di ghiaccio / Ice cube maker  
Machines à glaçons / Eisbereiter

# GH40AN-GH40WN GH50AN-GH50WN



**New**

	GH40AN - GH40WN	GH50AN - GH50WN
	570 W	
	230V / 50Hz	
1 Ph		
<b>GAS</b>	R290	
	40 Kg △ 21°C - ∅ 15°C	50 Kg △ 21°C - ∅ 15°C
	15 Kg	25 Kg
	W = Raffreddamento ad acqua - Water cooled A = Raffreddamento ad aria - Air cooled	
	elettronico / electronic	
<b>CONTROL</b>		
	500 x 600 x 685(h) mm (+0/20 mm piedini regolabili / adjustable feet)	500 x 600 x 795(h) mm (+0/20 mm piedini regolabili / adjustable feet)
	45 Kg	47 Kg
	50,5 Kg	53 Kg
	650 x 550 x 840(h) mm	650 x 550 x 940(h) mm



MADE IN ITALY

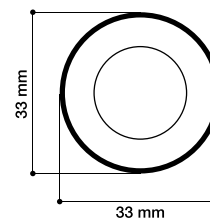
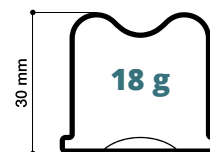

# GH60AN-GH60WN GH100AN-GH100WN

New



	GH60AN- GH60WN	GH100AN - GH100WN
	570 W	1080 W
	230V / 50Hz	
<b>GAS</b>	R290	
	60 Kg ⊕ 21°C - ⊖ 15°C	100 Kg ⊕ 21°C - ⊖ 15°C
	40 Kg	60 Kg
	W = Raffreddamento ad acqua - Water cooled A = Raffreddamento ad aria - Air cooled	
	elettronico / electronic	
<b>CONTROL</b>		
	736 x 620 x 800(h) mm (+125/190 mm piedini regolabili / adjustable feet)	736 x 620 x 985(h) mm (+125/190 mm piedini regolabili / adjustable feet)
	60 Kg	81 Kg
	68,5 Kg	89,5 Kg
	670 x 785 x 960(h) mm	670 x 785 x 1140(h) mm



MADE IN ITALY

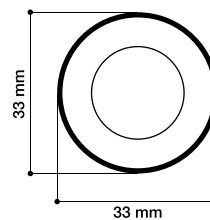
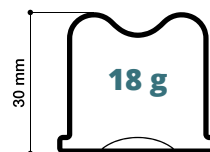

**forcar**  
by flmar REFRIGERATION

Premium Line

Fabbricatori di ghiaccio / Ice cube maker  
Machines à glaçons / Eisbereiter

# Armadi refrigerati GN2/1 - ventilati - Start Line

IT Armadi refrigerati GN2/1 in acciaio inox. Refrigerazione ventilata - gruppo incorporato - evaporatore posizionato a scomparsa in modo da avere massimo spazio disponibile - vano motore con fianchi coibentati - controllo temperatura elettronico con termostato digitale - resistenza elettrica intorno alla cornice porta per eliminazione della condensa - sbrinamento automatico e controllo automatico della temperatura di sbrinamento - evaporazione automatica dell'acqua di condensa - evaporatore trattato anticorrosione. Chiusura porta con chiave - guarnizione porta estraibile senza utensili - luce interna LED - fondo con angoli arrotondati - pannelli esterni di fondo e schienale in lamiera galvanizzata. Piedini in acciaio inox regolabili in altezza.

EN GN2/1 refrigerated cabinets made of stainless steel. Ventilated refrigeration - built-in unit - concealed evaporator for maximum available space - motor compartment with insulated sides - electronic temperature control with digital thermostat - electric heating element around the door frame to prevent condensation - automatic defrosting and automatic control of defrosting temperature - automatic evaporation of condensation water - anti-corrosion treated evaporator. Door lock with key - tool-free removable door gasket - internal LED light - bottom with rounded corners - external bottom and back panels in galvanised plate. Height-adjustable feet.

FR Armoires réfrigérées ventilées GN2/1 en acier inox. Réfrigération ventilée - unité intégrée - évaporateur escamotable pour le plus grand espace disponible - compartiment moteur avec côtés isolés - régulation électronique de la température avec thermostat digital - résistance électrique autour du cadre de la porte pour éliminer la condensation - dégivrage automatique et contrôle automatique de la température de dégivrage - évaporation automatique de l'eau de condensation - évaporateur traité anticorrosion. Serrure de porte avec clé - joint de porte amovible sans outils - éclairage interne par LED - fond avec coins arrondis - panneaux extérieurs de fond et de dos en tôle galvanisée. Pieds réglables en hauteur.

DE GN2/1 umluftgekühlte Edelstahl Kühlschränke. Umluftkühlung - eingebaute Motoreinheit - Verdampfer verdeckt positioniert, um maximalen Raum zu gewinnen - Motorraum mit isolierten Seiten - elektronische Temperaturregelung mit digitalem Thermostat - elektrisches Heizelement um den Türrahmen, um Kondenswasser zu beseitigen - automatische Abtauung und automatische Regelung der Abtautemperatur - automatische Verdampfung von Kondenswasser - korrosionsgeschützter Verdampfer. Türschloss mit Schlüssel - Türdichtung ohne Werkzeug abnehmbar - LED-Innenbeleuchtung - Boden mit abgerundeten Ecken - Außenboden und Rückwand aus verzinktem Blech. Edelstahl höhenverstellbare Füße.

## OPTIONAL

CG21	GRP21-FC	A64	RUO120	ACPED-FC
G-GN650TN-FC - G-GN650BT-FC				
GN2/1	GN2/1 650 x 535 mm	600 x 400 mm	ø 120 mm	
Coppia guide per griglia Pair of slides for grid Paire de glissières pour grille Führungsschienenpaar für Gitterrost	Griglia plastificata Plastic coated grid Grille plastifiée Kunststoffbeschichtetes Gitter	Kit supporti guide per teglie Slides-Bracket set Kit pour supports glissières Führungsschienen- und Trägersatz	Kit 4 ruote, di cui 2 con freno Set of 4 wheels, 2 with brake Jeu de 4 roues, 2 avec frein Satz mit 4 Rädern, 2 mit Bremsen	Pedale apertura porta Door opening pedal Pédale d'ouverture porte Türöffnungspedal

# G-GN650TN-FC G-GN650BT-FC



	G-GN650TN-FC	G-GN650BT-FC
	+2°C / +8°C	-18°C / -22°C
	740 x 830 x 2010(h) mm	
	620 x 700 x 1396(h) mm	
	650 L	
	+35°C / 55%HR	
	ventilata / ventilated	
<b>DEFROST</b>	automatico / automatic	
<b>GAS</b>	R290	
	automatica / automatic	
	elettronico / electronic	
	60 mm	
	305 W	520 W
	230V / 50Hz	
<b>MATERIAL</b>	acciaio Inox / stainless steel	
	si / yes	
	led	
<b>STANDARD</b>	3 griglie / grids GN2/1 3 coppie di guide / pairs of slides	
<b>ENERGY CLASS</b>	<b>D</b>	<b>E</b>
	120 Kg	124 Kg
	127 Kg	135 Kg
	765 x 855 x 2080(h) mm	

**FORCOLD**  
by flmar

## Start Line

Armadi refrigerati GN2/1 - ventilati / Refrigerated cabinets GN2/1 - Ventilated  
Armoires réfrigérées GN2/1 - ventilées / GN2/1 Kühlchränke - Umluftkühlung



Professional Line

# Armadi refrigerati

## GN2/1 - ventilati - Professional Line

**IT** Refrigerazione ventilata - gruppo incorporato - evaporatore posizionato a scomparsa in modo da avere massimo spazio disponibile - vano motore con fianchi coibentati - controllo temperatura elettronico con termostato digitale - resistenza elettrica intorno alla cornice porta per eliminazione della condensa - sbrinamento automatico - controllo elettronico della temperatura di sbrinamento - evaporazione automatica dell'acqua di condensa - evaporatore trattato anticorrosione. Porta con molla di ritorno e reversibile (escluso G-GNV600DT) - chiusura porta con chiave - guarnizione porta estraibile senza utensili - luce interna a LED - fondo con angoli arrotondati - pannelli esterni di fondo e schienale in lamiera galvanizzata. Piedini regolabili in altezza. I modelli M-GN sono dotati di unità refrigerante Monoblocco - gruppo refrigerante con sistema plug-in caratterizzato da installazione o eventuale rimozione/sostituzione facile ed immediata - motore più silenzioso - Monoblocco protetto da lamiera in acciaio inox.

**EN** Ventilated refrigeration - built-in unit - concealed evaporator for maximum available space - motor compartment with insulated sides - electronic temperature control with digital thermostat - electric heating element around the door frame to prevent condensation - automatic defrosting - electronic control of defrosting temperature - automatic evaporation of condensation water - anti-corrosion treated evaporator. Reversible door with self closing spring (except G-GNV600DT) - door lock with key - tool-free removable door gasket - internal LED light - bottom with rounded corners - external bottom and back panels in galvanised plate. Height-adjustable feet. M-GN models are equipped with Monobloc refrigerating unit - plug-in system refrigerating unit characterised by easy and immediate installation or eventual removal/replacement - quieter motor - Monobloc protected by stainless steel sheet.

**FR** Réfrigération ventilée - unité intégrée - évaporateur escamotable pour le plus grand espace disponible - compartiment moteur avec côtés isolés - régulation électronique de la température avec thermostat digital - résistance électrique autour du cadre de la porte pour éliminer la condensation - dégivrage automatique - contrôle électronique de la température de dégivrage - évaporation automatique de l'eau de condensation - évaporateur traité anticorrosion. Porte avec ressort de rappel et réversible (sauf G-GNV600DT) - serrure de porte avec clé - joint de porte amovible sans outils - éclairage interne par LED - fond avec coins arrondis - panneaux extérieurs de fond et de dos en tôle galvanisée. Pieds réglables en hauteur. Les modèles M-GN sont équipés d'un groupe frigorifique Monobloc - groupe frigorifique système plug-in caractérisé par une installation facile et immédiate ou par un éventuel démontage/remplacement - moteur plus silencieux - Monobloc protégé par une tôle en acier inox.

**DE** Umluftkühlung - eingebaute Motoreinheit - Verdampfer verdeckt positioniert, um maximalen Raum zu gewinnen - Motorraum mit isolierten Seiten - elektronische Temperaturregelung mit digitalem Thermostat - elektrisches Heizelement um den Türrahmen, um Kondenswasser zu beseitigen - automatische Abtauung - elektronische Regelung der Abtautemperatur - automatische Verdampfung von Kondenswasser - korrosionsgeschützter Verdampfer. Tür mit Rückholfeder und reversibel (außer G-GNV600DT) - Türschloss mit Schlüssel - Türdichtung ohne Werkzeug abnehmbar - LED-Innenbeleuchtung - Boden mit abgerundeten Ecken - Außenboden und Rückwand aus verzinktem Blech. Höhenverstellbare Füße. Die Modelle M-GN sind mit einem Monoblock-Kühlaggregat ausgestattet - Kühlaggregat mit Stecksystem, das sich durch eine einfache und sofortige Installation oder einen eventuellen Ausbau/Austausch auszeichnet - leiserer Motor - Monoblock durch Edelstahlblech geschützt.

## OPTIONAL

CG21	GRP21	GRP21-FC	A64	RUO120	ACPED	ACPED-FC
	G-GN	M-GN			G-650TN-BT G-650TNG-BTG	M-GN650TN-BT-FC M-GN650TNG-BTG-FC
GN2/1	GN2/1 640 x 530 mm	GN2/1 650 x 535 mm	600 x 400 mm	ø 120 mm		
Coppia guide per griglia Pair of slides for grid Paire de glissières pour grille Führungsschienenpaar für Gitterrost	Griglia plastificata Plastic coated grid Grille plastifiée Kunststoffbeschichtetes Gitter		Kit supporti guide per teglie Slides-Bracket set Kit pour supports glissières Führungsschienen- und Trägersa	Kit 4 ruote, di cui 2 con freno Set of 4 wheels, 2 with brake Jeu de 4 roues, 2 avec frein Satz mit 4 Rädern, 2 mit Bremse		Pedale apertura porta Door opening pedal Pédale d'ouverture porte Türöffnungspedal

# G-GN650TN G-GN650BT



	G-GN650TN	G-GN650BT
	-2°C / +8°C	-18°C / -22°C
	740 x 830 x 2010(h) mm	
	624 x 685 x 1396(h) mm	
	650 L	
	+32°C / 55%HR	
	ventilata / ventilated	
<b>DEFROST</b>	automatico / automatic	
<b>GAS</b>	R290	
	automatica / automatic	
	elettronico / electronic	
	60 mm	
	315 W	500 W
	230V / 50Hz	
<b>MATERIAL</b>	acciaio Inox / stainless steel AISI 304	
	si / yes	
	si / yes	
<b>STANDARD</b>	3 griglie / grids GN2/1 3 coppie di guide / pairs of slides	
<b>ENERGY CLASS</b>		
	134 Kg	138 Kg
	153 Kg	157 Kg
	765 x 855 x 2180(h) mm	

# M-GN650TN-FC M-GN650BT-FC



	M-GN650TN-FC	M-GN650BT-FC
	0°C / +8°C	-18°C / -22°C
	740 x 830 x 2010(h) mm	
	620 x 700 x 1396(h) mm	
	650 L	
	+38°C / 60%HR	
	ventilata / ventilated	
<b>DEFROST</b>	automatico / automatic	
<b>GAS</b>	R290	
	automatica / automatic	
	elettronico / electronic	
	60 mm	
	420 W	450 W
	230V / 50Hz	
<b>MATERIAL</b>	acciaio Inox / stainless steel	
	si / yes	
	led	
<b>STANDARD</b>	3 griglie / grids GN2/1 3 coppie di guide / pairs of slides	
<b>ENERGY CLASS</b>	<b>D</b>	<b>E</b>
	108 Kg	114 Kg
	123 Kg	129 Kg
	765 x 855 x 2080(h) mm	

**FORCOLD**  
by flmar

**MONOBLOCK**

## Professional Line

Armadi refrigerati GN2/1 - ventilati / Refrigerated cabinets GN2/1 - Ventilated  
Armoires réfrigérées GN2/1 - ventilées / GN2/1 Kühlchränke - Umluftkühlung

# G-GN650TNG G-GN650BTG



	G-GN650TNG	G-GN650BTG
	+2°C / +8°C	-18°C / -22°C
	740 x 830 x 2010(h) mm	
	624 x 685 x 1396(h) mm	
	650 L	
	+32°C / 55%HR	
	ventilata / ventilated	
<b>DEFROST</b>	automatico / automatic	
<b>GAS</b>	R290	
	automatica / automatic	
	elettronico / electronic	
	60 mm	
	315 W	500 W
	230V / 50Hz	
<b>MATERIAL</b>	acciaio inox / stainless steel AISI 304 + porta a vetro / glass door	
	no	
	si / yes	
<b>STANDARD</b>	3 griglie / grids GN2/1 3 coppie di guide / pairs of slides	
<b>ENERGY CLASS</b>		
	138 Kg	153 Kg
	157 Kg	173 Kg
	765 x 855 x 2180(h) mm	

# M-GN650TNG-FC M-GN650BTG-FC



	M-GN650TNG-FC	M-GN650BTG-FC
	0°C / +8°C	-18°C / -22°C
	740 x 830 x 2010(h) mm	
	620 x 700 x 1396(h) mm	
	650 L	
	+38°C / 60%HR	
	ventilata / ventilated	
<b>DEFROST</b>	automatico / automatic	
<b>GAS</b>	R290	
	automatica / automatic	
	elettronico / electronic	
	60 mm	
	305 W	520 W
	230V / 50Hz	
<b>MATERIAL</b>	acciaio inox / stainless steel + porta a vetro / glass door	
	no	
	led	
<b>STANDARD</b>	3 griglie / grids GN2/1 3 coppie di guide / pairs of slides	
<b>ENERGY CLASS</b>		
	125 Kg	140 Kg
	139 Kg	154 Kg
	765 x 855 x 2080(h) mm	

**FORCOLD**  
by flmar

**MONOBLOCK**

## Professional Line

Armadi refrigerati GN2/1 - ventilati / Refrigerated cabinets GN2/1 - Ventilated  
Armoires réfrigérées GN2/1 - ventilées / GN2/1 Kühlchränke - Umluftkühlung

# G-GN1410TN G-GN1410BT



	G-GN1410TN	G-GN1410BT
	-2°C / +8°C	-18°C / -22°C
	1480 x 830 x 2010(h) mm	
	1360 x 685 x 1390(h) mm	
	1325 L	
	+32°C / 55%HR	
	ventilata / ventilated	
<b>DEFROST</b>	automatico / automatic	
<b>GAS</b>	R290	
	automatica / automatic	
	elettronico / electronic	
	60 mm	
	320 W	730 W
	230V / 50Hz	
<b>MATERIAL</b>	acciaio Inox / stainless steel AISI 304	
	no	
	si / yes	
<b>STANDARD</b>	6 griglie / grids GN2/1 6 coppie di guide / pairs of slides	
<b>ENERGY CLASS</b>		
	195 Kg	208 Kg
	219 Kg	235 Kg
	1505 x 855 x 2180(h) mm	

# M-GN1410TN-FC M-GN1410BT-FC



	M-GN1410TN-FC	M-GN1410BT-FC
	0°C / +8°C	-18°C / -22°C
	1480 x 830 x 2010(h) mm	
	1360 x 632 x 1397(h) mm	
	1300 L	
	+38°C / 60%HR	
	ventilata / ventilated	
<b>DEFROST</b>	automatico / automatic	
<b>GAS</b>	R290	
	automatica / automatic	
	elettronico / electronic	
	60 mm	
	846 W	730 W
	230V / 50Hz	
<b>MATERIAL</b>	acciaio Inox / stainless steel	
	no	
	led	
<b>STANDARD</b>	6 griglie / grids GN2/1 6 coppie di guide / pairs of slides	
<b>ENERGY CLASS</b>		
	164 Kg	172 Kg
	189 Kg	197 Kg
	1505 x 855 x 2080(h) mm	

**FORCOLD**  
by flmar

**MONOBLOCK**

## Professional Line

Armadi refrigerati GN2/1 - ventilati / Refrigerated cabinets GN2/1 - Ventilated  
Armoires réfrigérées GN2/1 - ventilées / GN2/1 Kühlchränke - Umluftkühlung

# G-GN1410TNG



	<b>G-GN1410TNG</b>
	+2°C / +8°C
	1480 x 830 x 2010(h) mm
	1360 x 685 x 1390(h) mm
	1325 L
	+32°C / 55%HR
	ventilata / ventilated
<b>DEFROST</b>	automatico / automatic
<b>GAS</b>	R290
	automatica / automatic
	elettronico / electronic
<b>CONTROL</b>	60 mm
	500 W
	230V / 50Hz
	1 Ph
<b>MATERIAL</b>	acciaio inox / stainless steel AISI 304 + porta a vetro / glass door
	no
	si / yes
<b>STANDARD</b>	6 griglie / grids GN2/1 6 coppie di guide / pairs of slides
<b>ENERGY CLASS</b>	
	208 Kg
	235 Kg
	1505 x 855 x 2180(h) mm

# M-GN1410TNG-FC M-GN1410BTG-FC



	M-GN1410TNG-FC	M-GN1410BTG-FC
	0°C / +8°C	-18°C / -22°C
	1480 x 830 x 2010(h) mm	
	1360 x 700 x 1397(h) mm	
	1300 L	
	+38°C / 60%HR	
	ventilata / ventilated	
<b>DEFROST</b>	automatico / automatic	
<b>GAS</b>	R290	
	automatica / automatic	
	elettronico / electronic	
	60 mm	
	508 W	815 W
	230V / 50Hz	
<b>MATERIAL</b>	acciaio inox / stainless steel + porta a vetro / glass door	
<b>REVERSIBLE</b>	no	
	led	
<b>STANDARD</b>	6 griglie / grids GN2/1 6 coppie di guide / pairs of slides	
<b>ENERGY CLASS</b>		
	206 Kg	
	227 Kg	
	1505 x 855 x 2080(h) mm	

**FORCOLD**  
by flmar

**MONOBLOCK**

## Professional Line

Armadi refrigerati GN2/1 - ventilati / Refrigerated cabinets GN2/1 - Ventilated  
Armoires réfrigérées GN2/1 - ventilées / GN2/1 Kühlchränke - Umluftkühlung

# G-GNV600DT



	<b>G-GNV600DT</b>
	-2°C / +8°C -18°C / -22°C
	680 x 830 x 2010(h) mm
	530 x 650 x 550(h) mm 530 x 650 x 550(h) mm
	237 L / 237 L
	+32°C / 55%HR
	ventilata / ventilated
<b>DEFROST</b>	automatico / automatic
<b>GAS</b>	TN R600a / BT R290
	automatica / automatic
	elettronico / electronic
<b>CONTROL</b>	60 mm
	TN 250 W / BT 300 W
	230V / 50Hz 1 Ph
<b>MATERIAL</b>	acciaio Inox / stainless steel AISI 304
	no
	no
<b>STANDARD</b>	4 griglie / grids GN2/1 4 coppie di guide / pairs of slides
	150 Kg
	170 Kg
	710 x 875 x 2160(h) mm

# G-GNV1200DT



P60 (mod. GNV1200DT / 600 x 400 mm)

Kit supporti e 9 coppie di guide per teglie. Bracket set and 9 pairs of slides for pans.  
Kit de supports et 9 paires de glissières pour bacs. Trägersatz und 9 Paare Führungsschienen für Bleche.

	<b>G-GNV1200DT</b>
	-2°C / +8°C -18°C / -22°C
	1340 x 830 x 2010(h) mm
	530 x 650 x 1386(h) mm 530 x 650 x 1386(h) mm
	507 L / 507 L
	+32°C / 55%HR
	ventilata / ventilated
<b>DEFROST</b>	automatico / automatic
<b>GAS</b>	TN R290 / BT R290
	automatica / automatic
	elettronico / electronic
<b>CONTROL</b>	60 mm
	TN 255 W / BT 750 W
	230V / 50Hz
<b>MATERIAL</b>	acciaio Inox / stainless steel AISI 304
<b>REVERSIBLE</b>	no
	no
<b>STANDARD</b>	6 griglie / grids GN2/1 6 coppie di guide / pairs of slides
	195 Kg
	219 Kg
	1370 x 875 x 2160(h) mm

## Professional Line

Armadi refrigerati GN2/1 - ventilati / Refrigerated cabinets GN2/1 - Ventilated  
Armoires réfrigérées GN2/1 - ventilées / GN2/1 Kühlschränke - Umluftkühlung

# Armadi refrigerati

## GN2/1 - statici - Professional Line

IT Armadi refrigerati GN2/1. Refrigerazione statica - ventilatore e convogliatore d'aria interno per uniformare la temperatura - gruppo incorporato in vano superiore - vano motore con fianchi coibentati - controllo temperatura elettronico con termostato digitale - resistenza elettrica intorno alla cornice porta per eliminazione della condensa - eliminazione dell'acqua di condensa tramite bacinella. Porta con molla di ritorno e reversibile - chiusura porta con chiave - guarnizione porta estraibile senza utensili - fondo con angoli arrotondati - pannelli esterni di fondo e schienale in lamiera galvanizzata - piedini regolabili in altezza.

EN GN2/1 refrigerated cabinets. Static refrigeration - fan and internal air conveyor to uniform the temperature - incorporated refrigerating unit in the upper compartment - motor compartment with insulated sides - electronic temperature control with digital thermostat - electrical heating element around the door frame to prevent condensation - drip tray to collect condensation water. Reversible door with self closing spring - door lock with key - tool-free extractable door gasket - bottom with rounded corners - external back and bottom panels in galvanized plate - height-adjustable feet.

FR Armoires réfrigérées GN2/1. Réfrigération statique - ventilateur et convoyeur d'air interne pour uniformiser la température - groupe incorporé dans le compartiment supérieur - compartiment moteur avec côtés isolés - régulation électronique de la température avec thermostat digital - résistance électrique autour du cadre de porte pour éliminer la condensation - élimination de l'eau de condensation avec bac. Porte réversible avec ressort auto-fermant - fermeture de la porte par clé - joint de porte extractible sans outils - fond avec coins arrondis - panneaux de fond extérieurs et panneau postérieur en tôle galvanisée - pieds réglables en hauteur.

DE GN2/1 Kühlschränke. Statische Kühlung - Gebläse und interner Luftförderer zur Temperaturregelung - integrierte Einheit im oberen Raum - Motorraum mit isolierten Seiten - elektronische Temperaturregelung mit digitalem Thermostat - elektrischer Heizstab um den Türrahmen herum zur Vermeidung von Kondensation - Beseitigung von Kondenswasser durch eine Wanne. Umkehrbare Tür mit Rückholfeder - Türschließung mit Schlüssel - Türdichtung werkzeuglos abnehmbar - Boden mit abgerundeten Ecken - äußere Rücken - und Bodenverkleidung aus verzinktem Blech - Höhenverstellbare Füße.

## OPTIONAL

CG21	GRP21	GRP21-FC	RUO120	ACPED	ACPED-FC	P60
	G-GN600FISH G-GN600TN-BT	G-GN600TN-BT-FC		G-GN600FISH G-GN600TN-BT	G-GN600TN-BT-FC	G-GN600-1200DT
GN2/1	GN2/1 640 x 530 mm	GN2/1 650 x 535 mm	ø 120 mm			600 x 400 mm
Coppia guide per griglia Pair of slides for grid Paire de glissières pour grille Führungsschienenpaar für Gitterrost	Griglia plastificata Plastic coated grid Grille plastifiée Kunststoffbeschichtetes Gitter		Kit 4 ruote, di cui 2 con freno Set of 4 wheels, 2 with brake Jeu de 4 roues, 2 avec frein Satz mit 4 Rädern, 2 mit Bremse	Pedale apertura porta Door opening pedal Pédale d'ouverture porte Türöffnungspedal		Kit supporti e 9 coppie di guide per teglie Bracket set and 9 pairs of slides for pans Kit de supports et 9 paires de glissières pour bacs Trägersatz und 9 Paare Führungsschienen für Bleche

# G-GN600FISH



AV4909

cassetta / container

600 x 400 x 130(h) mm

Scopri tutti gli optional  
su Forcar Multiservice!  
Discover Forcar  
Multiservice optional!

G-GN600FISH	
	-5°C / 0°C
	680 x 810 x 2010(h) mm
	560 x 653 x 1386(h) mm
	507 L
	+32°C / 55%HR
	statica / static
<b>DEFROST</b>	manuale / manual
<b>GAS</b>	R290
	vasca di raccolta / collecting basin
	elettronico / electronic
<b>CONTROL</b>	60 mm
	260 W
	230V / 50Hz
<b>MATERIAL</b>	acciaio Inox / stainless steel AISI 304
<b>REVERSIBLE</b>	si / yes
	no
<b>STANDARD</b>	7 cassette / containers 600 x 400 x 130(h) mm
<b>ENERGY CLASS</b>	
<b>NET Kg</b>	135 Kg
<b>GROSS Kg</b>	165 Kg
	710 x 840 x 2180(h) mm



## Professional Line

Armadi refrigerati GN2/1 - statici / Refrigerated cabinets GN2/1 - Static  
Armoires réfrigérées GN2/1 - statiques / GN2/1 Kühlschränke - Statisch

# G-GN600TN G-GN600BT



	G-GN600TN	G-GN600BT
	+2°C / +8°C	-18°C / -22°C
	680 x 810 x 2010(h) mm	
	560 x 653 x 1386(h) mm	
	507 L	
	+32°C / 55%HR	
	statica / static	
<b>DEFROST</b>	automatico / automatic	manuale / manual
<b>GAS</b>	R290	
	vasca di raccolta / collecting basin	
	elettronico / electronic	
<b>CONTROL</b>	60 mm	
	260 W	510 W
	230V / 50Hz	
<b>MATERIAL</b>	acciaio Inox / stainless steel AISI 304	
	si / yes	
	no	
<b>STANDARD</b>	3 griglie / grids GN2/1 3 coppie di guide / pairs of slides	
<b>ENERGY CLASS</b>		
	135 Kg	
	155 Kg	
	710 x 840 x 2180(h) mm	

# G-GN600TN-FC G-GN600BT-FC



	G-GN600TN-FC	G-GN600BT-FC
	+2°C / +8°C	-18°C / -22°C
	680 x 810 x 2010(h) mm	
	560 x 680 x 1390(h) mm	
	507 L	
	+35°C / 50%HR	
	statica / static	
<b>DEFROST</b>	automatico / automatic	manuale / manual
<b>GAS</b>	R600a	R290
	vasca di raccolta / collecting basin	
	elettronico / electronic	
	60 mm	
	220 W	204 W
	230V / 50Hz	
	1 Ph	
<b>MATERIAL</b>	acciaio Inox / stainless steel	
	si / yes	
	no	
<b>STANDARD</b>	3 griglie / grids GN2/1 3 coppie di guide / pairs of slides	
<b>ENERGY CLASS</b>		
	104 Kg	114 Kg
	118 Kg	126 Kg
	710 x 840 x 2090(h) mm	



## Professional Line

Armadi refrigerati GN2/1 - statici / Refrigerated cabinets GN2/1 - Static  
Armoires réfrigérées GN2/1 - statiques / GN2/1 Kühlschränke - Statisch

# G-GN1200TN G-GN1200BT



	G-GN1200TN	G-GN1200BT
	+2°C / +8°C	-18°C / -22°C
	1340 x 810 x 2010(h) mm	
	1220 x 653 x 1386(h) mm	
	1104 L	
	+32°C / 55%HR	
	statica / static	
<b>DEFROST</b>	automatico / automatic	manuale / manual
<b>GAS</b>	R290	
	vasca di raccolta / collecting basin	
	elettronico / electronic	
<b>CONTROL</b>	60 mm	
	450 W	710 W
	230V / 50Hz	
<b>MATERIAL</b>	acciaio Inox / stainless steel AISI 304	
	no	
	no	
<b>STANDARD</b>	6 griglie / grids GN2/1 6 coppie di guide / pairs of slides	
<b>ENERGY CLASS</b>		
	180 Kg	
	204 Kg	
	1370 x 840 x 2180(h) mm	

# G-GN1200TN-FC G-GN1200BT-FC



	G-GN1200TN-FC	G-GN1200BT-FC
	+2°C / +8°C	-18°C / -22°C
	1340 x 810 x 2010(h) mm	
	1220 x 680 x 1390(h) mm	
	1104 L	
	+35°C / 50%HR	
	statica / static	
<b>DEFROST</b>	automatico / automatic	manuale / manual
<b>GAS</b>	R290	
	vasca di raccolta / collecting basin	
	elettronico / electronic	
<b>CONTROL</b>	60 mm	
	415 W	602 W
	230V / 50Hz	
<b>MATERIAL</b>	acciaio Inox / stainless steel	
	no	
	no	
<b>STANDARD</b>	6 griglie / grids GN2/1 6 coppie di guide / pairs of slides	
	163 Kg	174 Kg
	177 Kg	183 Kg
	1370 x 840 x 2090(h) mm	



## Professional Line

Armadi refrigerati GN2/1 - statici / Refrigerated cabinets GN2/1 - Static  
Armoires réfrigérées GN2/1 - statiques / GN2/1 Kühlschränke - Statisch

# G-GN1200DT



	<b>G-GN1200DT</b>
	+2°C / +8°C -18°C / -22°C
	1340 x 830 x 2010(h) mm
	560 x 530 x 1386(h) mm 560 x 530 x 1386(h) mm
	552 L / 552 L
	+32°C / 55%HR
	statica / static
<b>DEFROST</b>	automatico / automatic
<b>GAS</b>	TN R290 / BT R290
	vasca di raccolta / collecting basin
	elettronico / electronic
<b>CONTROL</b>	60 mm
	TN 260 W / BT 510 W
	230V / 50Hz
<b>MATERIAL</b>	acciaio Inox / stainless steel AISI 304
	no
	no
<b>STANDARD</b>	6 griglie / grids GN2/1 6 coppie di guide / pairs of slides
	195 Kg
	219 Kg
	1370 x 875 x 2160(h) mm



## Professional Line

Armadi refrigerati GN2/1 - statici / Refrigerated cabinets GN2/1 - Static  
Armoires réfrigérées GN2/1 - statiques / GN2/1 Kühlschränke - Statisch

# Armadi refrigerati

## statici - Linea Snack - Professional Line

IT Armadio refrigerato, linea Snack (contenitore di bibite). Refrigerazione statica. Ventilatore e convogliatore d'aria interno per uniformare la temperatura - gruppo incorporato in vano superiore - vano motore con fianchi coibentati - controllo temperatura elettronico con termostato digitale - resistenza elettrica intorno alla cornice porta per eliminazione della condensa - eliminazione dell'acqua di condensa tramite bacinella. Porta con molla di ritorno e reversibile - chiusura porta con chiave - guarnizione porta estraibile senza utensili - fondo con angoli arrotondati - pannelli esterni di fondo e schienale in lamiera galvanizzata - piedini in acciaio Inox AISI 304 regolabili in altezza.

EN Refrigerated cabinet, snack line (beverage container). Static refrigeration - fan and internal air conveyor to uniform the temperature - incorporated refrigerating unit in the upper compartment - motor compartment with insulated sides - electronic temperature control with digital thermostat - electrical heating element around the door frame to prevent condensation - drip tray to collect condensation water. Reversible door with self closing spring - door lock with key - tool-free extractable door gasket - bottom with rounded corners - external back and bottom panels in galvanized plate - height-adjustable feet in stainless steel AISI 304.

FR Armoires réfrigérées. ligne Snack (puor boissons). Réfrigération statique - ventilateur et convoyeur d'air interne pour uniformiser la température - groupe incorporé dans le compartiment supérieur - compartiment moteur avec côtés isolés - régulation électronique de la température avec thermostat digital - résistance électrique autour du cadre de porte pour éliminer la condensation - élimination de l'eau de condensation avec bac. Porte réversible avec ressort autofermant- fermeture de la porte par clé - joint de porte extractible sans outils- fond avec coins arrondis - panneaux de fond extérieurs et panneau postérieur en tôle galvanisée - pieds en acier inox AISI 304 réglables en hauteur.

DE Kühlschränke, Snack Line (Softdrinkbehälter). Umluftkühlung - Einbaueinheit - sichtbarer Verdampfer im Raum - Motorraum mit isolierten Seiten - elektronische Temperaturregelung mit Digitalthermostat - elektrischer Heizstab um den Türrahmen herum zur Vermeidung von Kondensation - Motorstoppabtauung - automatische Verdampfung des Kondenswassers. Umkehrbare Tür mit Rückholfeder - Türverschluss mit Schlüssel - Türdichtung werkzeuglos abnehmbar - Boden mit abgerundeten Ecken - äußere Rücken- und Bodenverkleidung aus verzinktem Blech - Höhenverstellbare Füße aus Edelstahl AISI 304.

## OPTIONAL

CGSN	GRPSN	RUO120	ACPED	ACPED-FC
G-SNACK400TN-BT - G-SNACK400TN-BT-FC			G-SNACK400TN-BT	G-SNACK400TN-BT-FC
	530 x 540 mm	ø 120 mm		
Coppia guide per griglia Pair of slides for grid Paire de glissières pour grille Führungsschiennenpaar für Gitterrost	Griglia plastificata Plastic coated grid Grille plastifiée Kunststoffbeschichtetes Gitter	Kit 4 ruote, di cui 2 con freno Set of 4 wheels, 2 with brake Jeu de 4 roues, 2 avec frein Satz mit 4 Rädern, 2 mit Bremse	Pedale apertura porta Door opening pedal Pédale d'ouverture porte Türöffnungspedal	

# G-SNACK400TN G-SNACK400BT



	G-SNACK400TN	G-SNACK400BT
	-2°C / +8°C	-18°C / -20°C
	680 x 700 x 2000(h) mm	
	560 x 580 x 1386(h) mm	
	429 L	
	+32°C / 55%HR	
	statica / static	
<b>DEFROST</b>	automatico / automatic	manuale / manual
<b>GAS</b>	R290	
	vasca di raccolta / collecting basin	
<b>CONTROL</b>	elettronico / electronic	
	50 mm	
	260 W	490 W
	230V / 50Hz	
<b>MATERIAL</b>	acciaio Inox / stainless steel AISI 304	
<b>REVERSIBLE</b>	si / yes	
	no	
<b>STANDARD</b>	3 griglie / grids 530 x 540 mm 3 coppie di guide / pairs of slides	
<b>ENERGY CLASS</b>		
	135 Kg	
	152 Kg	
	710 x 740 x 2180(h) mm	

# G-SNACK400TN-FC G-SNACK400BT-FC



	G-SNACK400TN-FC	G-SNACK400BT-FC
	-2°C / +8°C	-18°C / -22°C
	680 x 710 x 2010(h) mm	
	560 x 580 x 1390(h) mm	
	429 L	
	+35°C / 50%HR	
	statica / static	
<b>DEFROST</b>	automatico / automatic	manuale / manual
<b>GAS</b>	R600a	R290
	vasca di raccolta / collecting basin	
	elettronico / electronic	
	60 mm	
	215 W	675 W
	230V / 50Hz	
<b>MATERIAL</b>	acciaio Inox / stainless steel	
	si / yes	
	no	
<b>STANDARD</b>	3 griglie / grids 530 x 540 mm 3 coppie di guide / pairs of slides	
<b>ENERGY CLASS</b>		
	108 Kg	115 Kg
	118 Kg	125 Kg
	710 x 740 x 2090(h) mm	

**FORCOLD**  
by flmar

## Professional Line

Armadi refrigerati - statici - linea snack / Refrigerated cabinet - static - snack line  
Armoires réfrigérées -statiques - ligne Snack / Kühlschränke - Statisch - Serie Snack

# Tavoli refrigerati con lavello

## GN1/1 - ventilati - Professional Line

IT Tavoli refrigerati gastronomia GN1/1 con refrigerazione ventilata e lavello con vasca da 40x40x20 cm. Gruppo incorporato estraibile per facile manutenzione - andamento circolare dell'aria fredda in modo da non toccare direttamente il prodotto - controllo temperatura elettronico con termostato digitale - resistenza elettrica intorno alla cornice porta per eliminazione della condensa - sbrinamento automatico e controllo automatico della temperatura di sbrinamento - evaporazione automatica dell'acqua di condensa - evaporatore trattato anticorrosione. Porta con molla di ritorno - guarnizione porta estraibile senza utensili - fondo con angoli arrotondati - facile intercambiabilità porte con cassettiere da due e tre cassetti - cassettiere facilmente estraibili con guide telescopiche in acciaio inox. Piedini regolabili in altezza - schienale in acciaio inox.

EN GN1/1 gastronomy refrigerated counters with ventilated refrigeration and sink with 40x40x20 cm bowl. Removable built-in unit for easy maintenance - cold air circulation so as not to touch the product directly - electronic temperature control with digital thermostat - electric heating element around the door frame to eliminate condensation - automatic defrosting and automatic control of defrosting temperature - automatic evaporation of condensation water - anti-corrosion treated evaporator. Door with self-retracting spring - door gasket removable without tools - bottom with rounded corners - easy door replacement with two- and three-drawer drawers - easy pull-out drawers with telescopic stainless steel slides. Height adjustable feet - stainless steel back panel.

FR Comptoirs réfrigérés de gastronomie GN1/1 avec réfrigération ventilée et évier avec cuve de 40x40x20 cm. Unité d'encastrement amovible pour faciliter l'entretien - circulation de l'air froid pour ne pas toucher directement le produit - contrôle électronique de la température avec thermostat digital - résistance électrique autour du cadre de la porte pour éliminer la condensation - dégivrage automatique et contrôle automatique de la température de dégivrage - évaporation automatique de l'eau de condensation - évaporateur traité anti-corrosion. Porte avec ressort de rappel - joint de porte amovible sans outil - fond avec coins arrondis - porte facilement interchangeable avec les meubles à deux et trois tiroirs - tiroirs facilement extractibles grâce à des glissières télescopiques en acier inox. Pieds réglables en hauteur - panneau arrière en acier inox.

DE GN1/1 Gastronomie-Kühltische mit Umluftkühlung und Spüle mit 40x40x20 cm-Becken. Herausnehmbares Einbauelement für eine einfache Wartung - Kaltluftzirkulation, um das Produkt nicht direkt zu berühren - elektronische Temperaturregelung mit digitalem Thermostat - elektrisches Heizelement um den Türrahmen zur Beseitigung von Kondenswasser - automatische Abtauung und automatische Regelung der Abtautemperatur - automatische Verdunstung des Tauwassers - korrosionsgeschützter Verdampfer. Tür mit Rückholfeder - Türdichtung ohne Werkzeug abnehmbar - Boden mit abgerundeten Ecken - einfache Austauschbarkeit der Tür mit zwei und drei Schubladen - leicht herausziehbare Schubladen mit Teleskopführungen aus Edelstahl. Höhenverstellbare Füße - Rückwand aus Edelstahl.

## OPTIONAL

CG11	GRP11	C12	C13
G-GNS2200TN - G-GNS3200TN			
GN1/1	GN1/1 - 530 x 325 mm		
Coppia guide per griglia - Pair of slides for grid Paire de glissières pour grille Führungsschienenpaar für Gitterrost	Griglia plastificata - Plastic coated grid Grille plastifiée - Kunststoffbeschichtetes Gitter	Set. 2 cassetti - Set. 2 drawers Set. 2 tiroirs - Set. 2 Schubladen	Set. 3 cassetti - Set. 3 drawers Set. 3 tiroirs - Set. 3 Schubladen

# G-GNS2200TN



# G-GNS3200TN



	G-GNS2200TN	G-GNS3200TN
	-2°C / +8°C	
	1510 x 700 x 960(h) mm	2020 x 700 x 960(h) mm
	799 x 530 x 564(h) mm	1234 x 530 x 564(h) mm
	390 L	580 L
	+32°C / 55%HR	
	ventilata / ventilated	
<b>DEFROST</b>	automatico / automatic	
<b>GAS</b>	R600a	
	automatica / automatic	
	elettronico / electronic	
<b>CONTROL</b>	60 mm	
	300 W	
	230V / 50Hz	
<b>MATERIAL</b>	acciaio Inox / stainless steel AISI 304	
	no	
	no	
<b>STANDARD</b>	2 griglie / grids GN1/1 2 coppie di guide / pairs of slides	3 griglie / grids GN1/1 3 coppie di guide / pairs of slides
<b>ENERGY CLASS</b>		
	108 Kg	144 Kg
	138 Kg	161 Kg
	1010 x 1540 x 730(h) mm	1010 x 2050 x 730(h) mm



## Professional Line

Tavoli refrigerati gastronomia con lavello - GN1/1 - ventilati / Refrigerated counters with sink - GN1/1 - ventilated  
Comptoirs réfrigérés avec évier - GN1/1 - ventilé / Kühltsche mit Spülbecken - GN1/1 - umluftgekühlt

# Tavoli refrigerati gastronomia

## GN1/1 - UGN - SNACK - ventilati - Professional Line

IT Tavoli refrigerati gastronomia GN1/1 con refrigerazione ventilata. Disponibili nelle versioni con vetro (codici TNG), con altezza di 65 cm (codici UGN) e nella versione linea SNACK (profondità 600 mm). Gruppo incorporato estraibile per facile manutenzione - andamento circolare dell'aria fredda in modo da non toccare direttamente il prodotto - controllo temperatura elettronico con termostato digitale - resistenza elettrica intorno alla cornice porta per eliminazione della condensa - sbrinamento automatico e controllo automatico della temperatura di sbrinamento - evaporazione automatica dell'acqua di condensa - evaporatore trattato anticorrosione. I Modelli M sono dotati di unità refrigerante Monoblocco - gruppo refrigerante con sistema plug-in caratterizzato da installazione o eventuale rimozione/sostituzione facile ed immediata - Monoblocco in materiale plastico ad alto isolamento termico e completamente riciclabile. Porta con molla di ritorno - guarnizione porta estraibile senza utensili - fondo con angoli arrotondati - facile intercambiabilità porte con cassettiere da due e tre cassette - cassettiere facilmente estraibili con guide telescopiche in acciaio inox. Piedini regolabili in altezza - schienale in acciaio inox (solo per i G-GN).

EN GN1/1 gastronomy refrigerated counters with ventilated refrigeration. Available in versions with glass (TNG codes), with a height of 65 cm (UGN codes) and in the SNACK line version (depth 600 mm). Built-in extractable unit for easy maintenance - circular cold air flow to avoid direct contact with the product - electronic temperature control with digital thermostat - electric heating element around the door frame to prevent condensation - automatic defrosting and automatic control of defrosting temperature - automatic evaporation of condensation water - anti-corrosion treated evaporator. M Models are equipped with Monobloc refrigeration unit - plug-in system refrigeration unit featuring easy and immediate installation or eventual removal/replacement - the monoblock is made of a plastic material with a high level of thermal insulation and is fully recyclable. Door with self closing spring - tool-free removable door gasket - bottom with rounded corners - easy door interchangeability with two and three drawer units - easily removable drawer units with stainless steel telescopic slides. Height-adjustable feet - stainless steel back panel (G-GN only).

FR Tables réfrigérées GN1/1 pour la gastronomie avec réfrigération ventilée. Disponible dans les versions avec verre (codes TNG), avec une hauteur de 65 cm (codes UGN) et dans la version de la ligne SNACK (profondeur 600 mm). Unité intégrée amovible pour faciliter l'entretien - flux d'air froid circulaire pour ne pas toucher directement le produit - contrôle électronique de la température avec thermostat numérique - résistance électrique autour du cadre de la porte pour éliminer la condensation - dégivrage automatique et contrôle automatique de la température de dégivrage - évaporation automatique de l'eau de condensation - évaporateur traité anticorrosion. Les modèles M sont équipés d'un groupe frigorifique monobloc - groupe frigorifique à système plug-in caractérisé par une installation facile et immédiate ou un éventuel retrait/remplacement - le monobloc est fabriqué en matériel plastique à haute isolation thermique et est entièrement recyclable. Porte avec ressort de rappel - joint de porte amovible sans outils - fond avec coins arrondis - porte facilement interchangeable avec les blocs-tiroirs à deux ou trois tiroirs - blocs-tiroirs faciles à retirer avec glissières télescopiques en acier inox. Pieds réglables en hauteur - panneau arrière en acier inox (uniquement pour le modèle G-GN).

DE GN1/1 Gastronomie-Kühltsche mit Umluftkühlung. Erhältlich in den Versionen mit Glas (TNG-Codes), mit einer Höhe von 65 cm (UGN-Codes) und in der Version der Serie SNACK (Tiefe 600 mm). Herausnehmbare Einbaueinheit für eine einfache Wartung - Kaltluftumlauf, um das Produkt nicht direkt zu berühren - elektronische Temperaturregelung mit digitalem Thermostat - elektrisches Heistab um den Türrahmen zur Vermeidung von Kondenswasser - automatische Abtauung und automatische Regelung der Abtautemperatur - automatische Verdunstung des Kondenswassers - Verdämpfer mit Korrosionsschutz. Die Modelle M sind mit einer Monoblock-Kühleinheit ausgestattet - Kühleinheit mit plug-in-System, die sich durch eine einfache und sofortige Installation oder einen eventuellen Ausbau/Austausch auszeichnet - Der Monoblock besteht aus hochwärmedämmendem Kunststoff und ist vollständig wiederverwertbar. Tür mit Rückholfeder - Türdichtung ohne Werkzeug abnehmbar - Boden mit abgerundeten Ecken - einfache Austauschbarkeit der Tür mit zwei und drei Schubladenblöcken - leicht herausnehmbare Schubladenblöcke mit Teleskopschienen aus Edelstahl. Höhenverstellbare Füße - Rückwand aus Edelstahl (nur G-GN).

## OPTIONAL

CG11	CGG	GRP11	GRP11-FC	GRPG
All models G-GN - M-GN	All models G-SNACK	All models G-GN	All models M-GN	All models G-SNACK
GN1/1		GN1/1 530 x 325 mm	GN1/1-FC 530 x 333 mm	330 x 430 mm
Coppia guide per griglia - Pair of slides for grid Paire de glissières pour grille - Führungsschienenpaar für Gitterrost		Griglia plastificata - Plastic coated grid Grille plastifiée - Kunststoffbeschichtetes Gitter		

RJ0120	RJ0120.6
All models G-GN-SNACK-UGN2100-3100	All models G-GN-SNACK-UGN-4100
ø 120 mm	
Kit 4 ruote, di cui 2 con freno - Set of 4 wheels, 2 with brake Jeu de 4 roues, 2 avec frein - Satz mit 4 Rädern, 2 mit Bremse	Kit 6 ruote, di cui 3 con freno - Set of 6 wheels, 3 with brake Jeu de 6 roues, 3 avec frein - Satz mit 6 Rädern, 3 mit Bremse

C12	C12-FC	C12G	U12	C13	C13-FC	C13G
G-TN	M-TN-FC	G-SNACK	G-UGN	G-TN	M-TN-FC	G-SNACK
Set. 2 cassetti - Set. 2 drawers Set. 2 tiroirs - Set. 2 Schubladen				Set. 3 cassetti - Set. 3 drawers Set. 3 tiroirs - Set. 3 Schubladen		

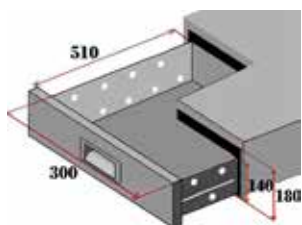

C12  
C12-FC

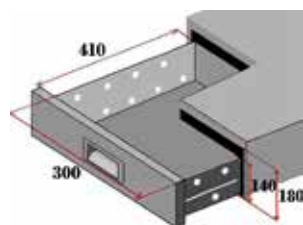

C12G

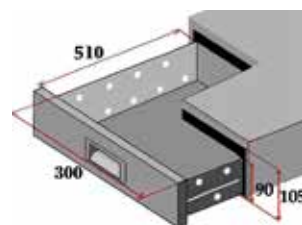

C13  
C13-FC/U12

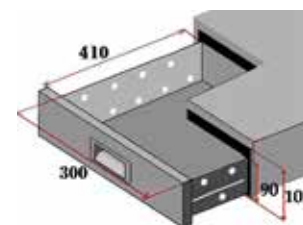

C13G

## Professional Line

Tavoli refrigerati gastronomia - GN1/1 - ventilati / Gastronomy refrigerated counters - GN1/1 - ventilated  
Tables réfrigérées gastronomie - GN1/1 - ventilées / Gastronomie-Kühltische - GN1/1 - Umluftkühlung

## G-GN2100TN / G-GN2100BT



## G-GN3100TN / G-GN3100BT











































## G-GN4100TN / G-GN4100BT



	G-GN2100TN	G-GN2100BT
	-2°C / +8°C	-18°C / -22°C
	1360 x 700 x 860(h) mm	
	902 x 530 x 589(h) mm	
	282 L	
	+32°C / 55%HR	
	ventilata / ventilated	
<b>DEFROST</b>	automatico / automatic	
<b>GAS</b>	R290	
	automatica / automatic	
	elettronico / electronic	
<b>CONTROL</b>	60 mm	
	260 W	470 W
	230V / 50Hz	
<b>1 Ph</b>		
<b>MATERIAL</b>	acciaio Inox / stainless steel AISI 304	
	no	
	no	
<b>STANDARD</b>	2 griglie / grids GN1/1 2 coppie di guide / pairs of slides	
<b>ENERGY CLASS</b>	<b>B</b>	<b>D</b>
	98 Kg	103 Kg
	121 Kg	126 Kg
	1390 x 730 x 1020(h) mm	

Cassetto neutro sopra vano tecnico  
Neutral drawer on technical compartment  
Tiroir neutre sur le compartiment technique  
Neutrale Schublade auf dem Technikraum

	G-GN3100TN	G-GN3100BT
	-2°C / +8°C	-18°C / -22°C
	1795 x 700 x 860(h) mm	
	1337 x 530 x 589(h) mm	
	417 L	
	+32°C / 55%HR	
	ventilata / ventilated	
<b>DEFROST</b>	automatico / automatic	
<b>GAS</b>	R290	
	automatica / automatic	
	elettronico / electronic	
	60 mm	
	260 W	570 W
	230V / 50Hz	
<b>MATERIAL</b>	acciaio Inox / stainless steel AISI 304	
	no	
	no	
<b>STANDARD</b>	3 griglie / grids GN1/1 3 coppie di guide / pairs of slides	
<b>ENERGY CLASS</b>		
		
	134 Kg	136 Kg
	159 Kg	162 Kg
	1825 x 730 x 1020(h) mm	

	G-GN4100TN	G-GN4100BT
	-2°C / +8°C	-18°C / -22°C
	2230 x 700 x 860(h) mm	
	1772 x 530 x 589(h) mm	
	553 L	
	+32°C / 55%HR	
	ventilata / ventilated	
<b>DEFROST</b>	automatico / automatic	
<b>GAS</b>	R290	
	automatica / automatic	
	elettronico / electronic	
	60 mm	
	260 W	660 W
	230V / 50Hz	
<b>MATERIAL</b>	acciaio Inox / stainless steel AISI 304	
	no	
	no	
<b>STANDARD</b>	4 griglie / grids GN1/1 4 coppie di guide / pairs of slides	
<b>ENERGY CLASS</b>		
		
	153 Kg	155 Kg
	187 Kg	189 Kg
	2260 x 730 x 1040(h) mm	

## Professional Line

Tavoli refrigerati gastronomia - GN1/1 - ventilati / Gastronomy refrigerated counters - GN1/1 - ventilated  
Tables réfrigérées gastronomie - GN1/1 - ventilées / Gastronomie-Kühltische - GN1/1 - Umluftkühlung

M-GN2100TN-FC  
M-GN2100BT-FC





















M-GN3100TN-FC  
M-GN3100BT-FC





















M-GN4100TN-FC  
M-GN4100BT-FC



	M-GN2100TN-FC	M-GN2100BT-FC
	0°C / +8°C	-18°C / -22°C
	1360 x 700 x 850(h) mm	
	900 x 530 x 560(h) mm	
	282 L	
	+35°C / 55%HR	
	ventilata / ventilated	
<b>DEFROST</b>	automatico / automatic	
<b>GAS</b>	R600a	R290
	automatica / automatic	
	elettronico / electronic	
<b>CONTROL</b>	60 mm	
	340 W	675 W
	230V / 50Hz	
<b>MATERIAL</b>	acciaio Inox / stainless steel	
	no	
	no	
<b>STANDARD</b>	2 griglie / grids GN1/1 2 coppie di guide / pairs of slides	
<b>ENERGY CLASS</b>	<b>D</b>	<b>E</b>
	88 Kg	96 Kg
	106 Kg	114 Kg
	1390 x 730 x 880(h) mm	

	M-GN3100TN-FC	M-GN3100BT-FC
	0°C / +8°C	-18°C / -22°C
	1795 x 700 x 850(h) mm	
	1335 x 530 x 560(h) mm	
	417 L	
	+35°C / 55%HR	
	ventilata / ventilated	
<b>DEFROST</b>	automatico / automatic	
<b>GAS</b>	R600a	R290
	automatica / automatic	
	elettronico / electronic	
	60 mm	
	340 W	366 W
	230V / 50Hz	
<b>MATERIAL</b>	acciaio Inox / stainless steel	
	no	
	no	
<b>STANDARD</b>	3 griglie / grids GN1/1 3 coppie di guide / pairs of slides	
<b>ENERGY CLASS</b>	<b>D</b>	<b>E</b>
		
	108 Kg	117 Kg
	128 Kg	137 Kg
	1825 x 730 x 880(h) mm	

	M-GN4100TN-FC	M-GN4100BT-FC
	0°C / +8°C	-18°C / -22°C
	2230 x 700 x 850(h) mm	
	1772 x 630 x 560(h) mm	
	553 L	
	+35°C / 55%HR	
	ventilata / ventilated	
<b>DEFROST</b>	automatico / automatic	
<b>GAS</b>	R290	
	automatica / automatic	
	elettronico / electronic	
	60 mm	
	380 W	675 W
	230V / 50Hz	
<b>MATERIAL</b>	acciaio Inox / stainless steel	
	no	
	no	
<b>STANDARD</b>	4 griglie / grids GN1/1 4 coppie di guide / pairs of slides	
<b>ENERGY CLASS</b>	<b>D</b>	<b>E</b>
		
	133 Kg	144 Kg
	160 Kg	171 Kg
	2260 x 760 x 880(h) mm	

## Professional Line

Tavoli refrigerati gastronomia - GN1/1 - ventilati / Gastronomy refrigerated counters - GN1/1 - ventilated  
Tables réfrigérées gastronomie - GN1/1 - ventilées / Gastronomie-Kühltische - GN1/1 - Umluftkühlung

## G-GN2200TN / G-GN2200BT



## G-GN3200TN / G-GN3200BT







































## G-GN4200TN / G-GN4200BT



	G-GN2200TN	G-GN2200BT
	-2°C / +8°C	-18°C / -22°C
	1360 x 700 x 860/960(h) mm	
	902 x 530 x 589(h) mm	
	282 L	
	+32°C / 55%HR	
	ventilata / ventilated	
<b>DEFROST</b>	automatico / automatic	
<b>GAS</b>	R290	
	automatica / automatic	
	elettronico / electronic	
<b>CONTROL</b>	60 mm	
	260 W	470 W
	230V / 50Hz	
<b>1 Ph</b>		
<b>MATERIAL</b>	acciaio Inox / stainless steel AISI 304	
	no	
<b>REVERSIBLE</b>		
	no	
<b>STANDARD</b>	2 griglie / grids GN1/1 2 coppie di guide / pairs of slides	
<b>ENERGY CLASS</b>	<b>B</b>	<b>D</b>
	108 Kg	111 Kg
	146 Kg	149 Kg
	1390 x 730 x 1120(h) mm	

Cassetto neutro sopra vano tecnico  
Neutral drawer on technical compartment  
Tiroir neutre sur le compartiment technique  
Neutrale Schublade auf dem Technikraum

	G-GN3200TN	G-GN3200BT
	-2°C / +8°C	-18°C / -22°C
	1795 x 700 x 860/960(h) mm	
	1337 x 530 x 589(h) mm	
	417 L	
	+32°C / 55%HR	
	ventilata / ventilated	
<b>DEFROST</b>	automatico / automatic	
<b>GAS</b>	R290	
	automatica / automatic	
	elettronico / electronic	
	60 mm	
	260 W	570 W
	230V / 50Hz	
<b>MATERIAL</b>	acciaio Inox / stainless steel AISI 304	
	no	
	no	
<b>STANDARD</b>	3 griglie / grids GN1/1 3 coppie di guide / pairs of slides	
<b>ENERGY CLASS</b>	<b>B</b>	<b>D</b>
		
	139 Kg	143 Kg
	187 Kg	191 Kg
	1825 x 730 x 1120(h) mm	

	G-GN4200TN	G-GN4200BT
	-2°C / +8°C	-18°C / -22°C
	2230 x 700 x 860/960(h) mm	
	1772 x 530 x 589(h) mm	
	553 L	
	+32°C / 55%HR	
	ventilata / ventilated	
<b>DEFROST</b>	automatico / automatic	
<b>GAS</b>	R290	
	automatica / automatic	
	elettronico / electronic	
	60 mm	
	260 W	660 W
	230V / 50Hz	
<b>MATERIAL</b>	acciaio Inox / stainless steel AISI 304	
	no	
	no	
<b>STANDARD</b>	4 griglie / grids GN1/1 4 coppie di guide / pairs of slides	
<b>ENERGY CLASS</b>	<b>C</b>	<b>E</b>
		
	172 Kg	144 Kg
	215 Kg	218 Kg
	2260 x 730 x 1140(h) mm	

## Professional Line

Tavoli refrigerati gastronomia - GN1/1 - ventilati / Gastronomy refrigerated counters - GN1/1 - ventilated  
Tables réfrigérées gastronomie - GN1/1 - ventilées / Gastronomie-Kühltische - GN1/1 - Umluftkühlung

M-GN2200TN-FC  
M-GN2200BT-FC





















M-GN3200TN-FC  
M-GN3200BT-FC





















M-GN4200TN-FC  
M-GN4200BT-FC



	M-GN2200TN-FC	M-GN2200BT-FC
	0°C / +8°C	-18°C / -22°C
	1360 x 700 x 850/950(h) mm	
	900 x 530 x 560(h) mm	
	282 L	
	+35°C / 55%HR	
	ventilata / ventilated	
<b>DEFROST</b>	automatico / automatic	
<b>GAS</b>	R600a	R290
	automatica / automatic	
	elettronico / electronic	
<b>CONTROL</b>	60 mm	
	340 W	675 W
	230V / 50Hz	
<b>1 Ph</b>		
<b>MATERIAL</b>	acciaio Inox / stainless steel	
	no	
<b>REVERSIBLE</b>		
	no	
<b>STANDARD</b>	2 griglie / grids GN1/1 2 coppie di guide / pairs of slides	
<b>ENERGY CLASS</b>		
	88 Kg	96 Kg
	106 Kg	114 Kg
	1390 x 730 x 880(h) mm	

	M-GN3200TN-FC	M-GN3200BT-FC
	0°C / +8°C	-18°C / -22°C
	1795 x 700 x 850/950(h) mm	
	1335 x 530 x 560(h) mm	
	417 L	
	+35°C / 55%HR	
	ventilata / ventilated	
<b>DEFROST</b>	automatico / automatic	
<b>GAS</b>	R600a	R290
	automatica / automatic	
	elettronico / electronic	
	60 mm	
	340 W	366 W
	230V / 50Hz	
<b>MATERIAL</b>	acciaio Inox / stainless steel	
	no	
	no	
<b>STANDARD</b>	3 griglie / grids GN1/1 3 coppie di guide / pairs of slides	
<b>ENERGY CLASS</b>	<b>D</b>	<b>E</b>
		
	108 Kg	117 Kg
	128 Kg	137 Kg
	1825 x 730 x 880(h) mm	

	M-GN4200TN-FC	M-GN4200BT-FC
	0°C / +8°C	-18°C / -22°C
	2230 x 700 x 850/950(h) mm	
	1772 x 630 x 560(h) mm	
	553 L	
	+35°C / 55%HR	
	ventilata / ventilated	
<b>DEFROST</b>	automatico / automatic	
<b>GAS</b>	R290	
	automatica / automatic	
	elettronico / electronic	
	60 mm	
	380 W	366 W
	230V / 50Hz	
<b>MATERIAL</b>	acciaio Inox / stainless steel	
	no	
	no	
<b>STANDARD</b>	4 griglie / grids GN1/1 4 coppie di guide / pairs of slides	
<b>ENERGY CLASS</b>	<b>D</b>	<b>E</b>
		
	133 Kg	144 Kg
	160 Kg	171 Kg
	2260 x 760 x 880(h) mm	

## Professional Line

Tavoli refrigerati gastronomia - GN1/1 - ventilati / Gastronomy refrigerated counters - GN1/1 - ventilated  
Tables réfrigérées gastronomie - GN1/1 - ventilées / Gastronomie-Kühltische - GN1/1 - Umluftkühlung

## G-GN2100TNG / G-GN2200TNG



G-GN2100TNG

G-GN2200TNG

## G-GN3100TNG / G-GN3200TNG



G-GN3100TNG

G-GN3200TNG

## G-GN4100TNG / G-GN4200TNG





















G-GN4100TNG



















G-GN4200TNG

	G-GN2100TNG	G-GN2200TNG
	-2°C / +8°C	
	1360 x 700 x 860(h) mm	1360 x 700 x 860/960(h) mm
	902 x 530 x 589(h) mm	
	282 L	
	+32°C / 55%HR	
	ventilata / ventilated	
<b>DEFROST</b>	automatico / automatic	
<b>GAS</b>	R290	
	automatica / automatic	
	elettronico / electronic	
	60 mm	
	260 W	
	230V / 50Hz	
<b>MATERIAL</b>	acciaio Inox / stainless steel AISI 304	
<b>REVERSIBLE</b>	no	
	si / yes	
<b>STANDARD</b>	2 griglie / grids GN1/1 2 coppie di guide / pairs of slides	
<b>ENERGY CLASS</b>	<b>B</b>	
	98 Kg	108 Kg
	121 Kg	146 Kg
	1390 x 730 x 1020(h) mm	1390 x 730 x 1120(h) mm

Cassetto neutro sopra vano tecnico  
Neutral drawer on technical compartment  
Tiroir neutre sur le compartiment technique  
Neutrale Schublade auf dem Technikraum



	G-GN3100TNG	G-GN3200TNG
	-2°C / +8°C	
	1795 x 700 x 860(h) mm	1795 x 700 x 860/960(h) mm
	1337 x 530 x 589(h) mm	
	417 L	
	+32°C / 55%HR	
	ventilata / ventilated	
<b>DEFROST</b>	automatico / automatic	
<b>GAS</b>	R290	
	automatica / automatic	
	elettronico / electronic	
	60 mm	
	260 W	
	230V / 50Hz	
<b>MATERIAL</b>	acciaio Inox / stainless steel AISI 304	
	no	
	si / yes	
<b>STANDARD</b>	3 griglie / grids GN1/1 3 coppie di guide / pairs of slides	
<b>ENERGY CLASS</b>		
		
	134 Kg	139 Kg
	162 Kg	190 Kg
	1825 x 730 x 1020(h) mm	1825 x 730 x 1120(h) mm

	G-GN4100TNG	G-GN4200TNG
	-2°C / +8°C	
	2230 x 700 x 860(h) mm	2230 x 700 x 860/960(h) mm
	1772 x 530 x 589(h) mm	
	553 L	
	+32°C / 55%HR	
	ventilata / ventilated	
<b>DEFROST</b>	automatico / automatic	
<b>GAS</b>	R290	
	automatica / automatic	
	elettronico / electronic	
	60 mm	
	260 W	
	230V / 50Hz	
<b>MATERIAL</b>	acciaio Inox / stainless steel AISI 304	
	no	
	si / yes	
<b>STANDARD</b>	4 griglie / grids GN1/1 4 coppie di guide / pairs of slides	
<b>ENERGY CLASS</b>		
		
	153 Kg	172 Kg
	176 Kg	215 Kg
	2260 x 730 x 1040(h) mm	2260 x 730 x 1140(h) mm

## Professional Line

Tavoli refrigerati gastronomia - GN1/1 - ventilati / Gastronomy refrigerated counters - GN1/1 - ventilated  
Tables réfrigérées gastronomie - GN1/1 - ventilées / Gastronomie-Kühltische - GN1/1 - Umluftkühlung

## G-UGN2100TN





















## G-UGN3100TN





















## G-UGN4100TN



G-UGN2100TN	
	-2°C / +8°C
	1360 x 700 x 650(h) mm
	902 x 530 x 355(h) mm
	170 L
	+32°C / 55%HR
	ventilata / ventilated
<b>DEFROST</b>	automatico / automatic
<b>GAS</b>	R290
	automatica / automatic
	elettronico / electronic
	60 mm
	260 W
	230V / 50Hz
<b>MATERIAL</b>	acciaio Inox / stainless steel AISI 304
<b>REVERSIBLE</b>	no
	no
<b>STANDARD</b>	2 griglie / grids GN1/1 2 coppie di guide / pairs of slides
<b>ENERGY CLASS</b>	<b>B</b>
	82 Kg
	103 Kg
	1390 x 730 x 810(h) mm

	G-UGN3100TN
	-2°C / +8°C
	1795 x 700 x 650(h) mm
	1337 x 530 x 355(h) mm
	262 L
	+32°C / 55%HR
	ventilata / ventilated
<b>DEFROST</b>	automatico / automatic
<b>GAS</b>	R290
	automatica / automatic
	elettronico / electronic
	60 mm
	260 W
	230V / 50Hz
<b>1 Ph</b>	
<b>MATERIAL</b>	acciaio Inox / stainless steel AISI 304
	no
<b>REVERSIBLE</b>	
	no
<b>STANDARD</b>	3 griglie / grids GN1/1 3 coppie di guide / pairs of slides
<b>ENERGY CLASS</b>	<b>B</b>
	
	106 Kg
	133 Kg
	1825 x 730 x 810(h) mm

	G-UGN4100TN
	-2°C / +8°C
	2230 x 700 x 650(h) mm
	1772 x 530 x 355(h) mm
	350 L
	+32°C / 55%HR
	ventilata / ventilated
<b>DEFROST</b>	automatico / automatic
<b>GAS</b>	R290
	automatica / automatic
	elettronico / electronic
	60 mm
	260 W
	230V / 50Hz
<b>1 Ph</b>	
<b>MATERIAL</b>	acciaio Inox / stainless steel AISI 304
	no
<b>REVERSIBLE</b>	
	no
<b>STANDARD</b>	4 griglie / grids GN1/1 4 coppie di guide / pairs of slides
<b>ENERGY CLASS</b>	<b>C</b>
	
	130 Kg
	165 Kg
	2260 x 730 x 810(h) mm

## Professional Line

Tavoli refrigerati gastronomia - UGN - ventilati / Gastronomy refrigerated counters - UGN - ventilated  
Tables réfrigérées gastronomie - UGN - ventilées / Gastronomie-Kühltische - UGN - Umluftkühlung

## G-SNACK2100TN / G-SNACK2200TN



G-SNACK2100TN

G-SNACK2200TN

## G-SNACK3100TN / G-SNACK3200TN



G-SNACK3100TN

G-SNACK3200TN

## G-SNACK4100TN / G-SNACK4200TN





















G-SNACK4100TN



















G-SNACK4200TN

	G-SNACK2100TN	G-SNACK2200TN
	-2°C / +8°C	
	1360 x 600 x 860(h) mm	1360 x 600 x 860/960(h) mm
	902 x 430 x 589(h) mm	
	228 L	
	+32°C / 55%HR	
	ventilata / ventilated	
<b>DEFROST</b>	automatico / automatic	
<b>GAS</b>	R290	
	automatica / automatic	
	elettronico / electronic	
	60 mm	
	260 W	
	230V / 50Hz	
<b>MATERIAL</b>	acciaio Inox / stainless steel AISI 304	
<b>REVERSIBLE</b>	no	
	no	
<b>STANDARD</b>	2 griglie / grids 330 x 430 mm 2 coppie di guide / pairs of slides	
<b>ENERGY CLASS</b>	<b>B</b>	
	88 Kg	97 Kg
	111 Kg	127 Kg
	1390 x 630 x 1020(h) mm	1390 x 630 x 1120(h) mm



Cassetto neutro sopra vano tecnico  
Neutral drawer on technical compartment  
Tiroir neutre sur le compartiment technique  
Neutrale Schublade auf dem Technikraum

	G-SNACK3100TN	G-SNACK3200TN
	-2°C / +8°C	
	1795 x 600 x 860(h) mm	1795 x 600 x 860/960(h) mm
	1337 x 430 x 589(h) mm	
	339 L	
	+32°C / 55%HR	
	ventilata / ventilated	
<b>DEFROST</b>	automatico / automatic	
<b>GAS</b>	R290	
	automatica / automatic	
	elettronico / electronic	
<b>CONTROL</b>	60 mm	
	260 W	
	230V / 50Hz	
<b>1 Ph</b>		
<b>MATERIAL</b>	acciaio Inox / stainless steel AISI 304	
	no	
<b>REVERSIBLE</b>		
	no	
<b>STANDARD</b>	3 griglie / grids 330 x 430 mm 3 coppie di guide / pairs of slides	
<b>ENERGY CLASS</b>		
		
	125 Kg	136 Kg
	156 Kg	168 Kg
	1825 x 630 x 1020(h) mm	1825 x 630 x 1120(h) mm

	G-SNACK4100TN	G-SNACK4200TN
	-2°C / +8°C	
	2230 x 600 x 860(h) mm	2230 x 600 x 860/960(h) mm
	1772 x 430 x 589(h) mm	
	449 L	
	+32°C / 55%HR	
	ventilata / ventilated	
<b>DEFROST</b>	automatico / automatic	
<b>GAS</b>	R290	
	automatica / automatic	
	elettronico / electronic	
<b>CONTROL</b>	60 mm	
	260 W	
	230V / 50Hz	
<b>1 Ph</b>		
<b>MATERIAL</b>	acciaio Inox / stainless steel AISI 304	
	no	
<b>REVERSIBLE</b>		
	no	
<b>STANDARD</b>	4 griglie / grids 330 x 430 mm 4 coppie di guide / pairs of slides	
<b>ENERGY CLASS</b>		
		
	143 Kg	160 Kg
	177 Kg	204 Kg
	2260 x 630 x 1040(h) mm	2260 x 630 x 1140(h) mm

## Professional Line

Tavoli refrigerati SNACK - ventilati/ Refrigerated counters SNACK - ventilated  
Tables réfrigérées SNACK - ventilées / Kühltische SNACK - Umluftkühlung

G-SNACK2100TN-FC  
G-SNACK2200TN-FC





















G-SNACK3100TN-FC  
G-SNACK3200TN-FC





















G-SNACK4100TN-FC  
G-SNACK4200TN-FC



	G-SNACK2100TN-FC	G-SNACK2200TN-FC
	-2°C / +8°C	
	1360 x 600 x 850(h) mm	1360 x 600 x 850/950(h) mm
	900 x 430 x 560(h) mm	
	228 L	
	+35°C / 50%HR	
	ventilata / ventilated	
<b>DEFROST</b>	automatico / automatic	
<b>GAS</b>	R600a	
	automatica / automatic	
	elettronico / electronic	
<b>CONTROL</b>	60 mm	
	275 W	
	230V / 50Hz	
	1 Ph	
<b>MATERIAL</b>	acciaio Inox / stainless steel	
	no	
	no	
<b>STANDARD</b>	2 griglie / grids 330 x 430 mm 2 coppie di guide / pairs of slides	
<b>ENERGY CLASS</b>		
	94 Kg	
	109 Kg	
	1390 x 630 x 880(h) mm	1390 x 630 x 980(h) mm

	G-SNACK3100TN-FC	G-SNACK3200TN-FC
	-2°C / +8°C	
	1795 x 600 x 850(h) mm	1795 x 600 x 850/950(h) mm
	1335 x 430 x 560(h) mm	
	339 L	
	+35°C / 50%HR	
	ventilata / ventilated	
<b>DEFROST</b>	automatico / automatic	
<b>GAS</b>	R600a	
	automatica / automatic	
	elettronico / electronic	
	60 mm	
	275 W	
	230V / 50Hz	
<b>MATERIAL</b>	acciaio Inox / stainless steel	
	no	
	no	
<b>STANDARD</b>	3 griglie / grids 330 x 430 mm 3 coppie di guide / pairs of slides	
<b>ENERGY CLASS</b>		
		
	103 Kg	
	127 Kg	
	1825 x 630 x 880(h) mm	1825 x 630 x 980(h) mm

	G-SNACK4100TN-FC	G-SNACK4200TN-FC
	-2°C / +8°C	
	2230 x 600 x 850(h) mm	2230 x 600 x 850/950(h) mm
	1172 x 430 x 560(h) mm	
	449 L	
	+35°C / 50%HR	
	ventilata / ventilated	
<b>DEFROST</b>	automatico / automatic	
<b>GAS</b>	R600a	
	automatica / automatic	
	elettronico / electronic	
	60 mm	
	398 W	
	230V / 50Hz	
<b>MATERIAL</b>	acciaio Inox / stainless steel	
	no	
	no	
<b>STANDARD</b>	4 griglie / grids 330 x 430 mm 4 coppie di guide / pairs of slides	
<b>ENERGY CLASS</b>		
		
	194 Kg	
	225 Kg	
	2260 x 630 x 880(h) mm	2260 x 630 x 980(h) mm

## Professional Line

Tavoli refrigerati SNACK - ventilati/ Refrigerated counters SNACK - ventilated  
Tables réfrigérées SNACK - ventilées / Kühltische SNACK - Umluftkühlung

# Cassettiere refrigerate con ruote

## GN1/1 - ventilate - Professional Line

IT Cassettiere refrigerate con ruote per contenimento bacinelle GN1/1 altezza 150 mm. Cassetti individualmente convertibili al tocco di un tasto (R/F) da temperatura negativa a positiva (da BT a TN), refrigerazione ventilata per veloce discesa di temperatura, sbrinamento automatico.  
I modelli con cassettera doppia G-CBR 22/23 hanno 2 unità refrigeranti che possono essere usate indipendentemente con temperature differenti  
Struttura in acciaio inox AISI 304 - controllo temperatura elettronico - isolamento di 50 mm. Bacinelle escluse.

EN Refrigerated Drawer units with wheels GN1/1 - ventilated - Professional Line  
Refrigerated drawer units with wheels to contain GN1/1 containers, height 150 mm. Drawers individually convertible at the touch of a button (R/F) from negative to positive temperature (BT to TN), ventilated refrigeration for fast temperature drop, automatic defrost.  
G-CBR 22/23 double drawer models have 2 refrigeration units that can be used independently with different temperatures  
Stainless steel AISI 304 casing - electronic temperature control - 50 mm insulation. Container excluded.

FR Éléments à tiroirs réfrigérés avec roues pour le stockage de bacs GN1/1 d'une hauteur de 150 mm. Tiroirs individuellement convertibles sur simple pression d'un bouton (R/F) de la température négative à la température positive (BT à TN), réfrigération ventilée pour une baisse rapide de la température, dégivrage automatique.  
Les modèles à double tiroir G-CBR 22/23 ont 2 unités de réfrigération qui peuvent être utilisées indépendamment avec des températures différentes  
Construction en acier inox AISI 304 - contrôle électronique de la température - isolation de 50 mm. Bacs exclus.

DE Gekühlte Schubladenelemente mit Rädern zur Aufnahme von GN1/1-Blechen, Höhe 150 mm. Die Schubladen können per Knopfdruck (R/F) individuell von Minus- auf Plus-Temperatur (BT auf TN) umgestellt werden, Umluftkühlung für schnellen Temperaturabfall, automatische Abtauung.  
Die Modelle G-CBR 22/23 mit zwei Schubladen verfügen über 2 Kühleinheiten, die unabhängig voneinander mit unterschiedlichen Temperaturen betrieben werden können  
Gehäuse aus Edelstahl AISI 304 - elektronische Temperaturregelung - 50 mm Isolierung. Ohne Blechen.

### OPTIONAL

GNI1150

GN1/1 - 150(h) mm

Bacinella - Container  
Bassine - Behälter

SCOPRI TUTTI I NOSTRI ACCESSORI SUL CATALOGO MULTISERVICE!  
DISCOVER OUR OPTIONAL ON MULTISERVICE CATALOGUE!

IT Rapida conversione da temperatura negativa a positiva tramite pulsante R/F.

EN Quick conversion from negative to positive temperature via R/F button.

FR Conversion rapide de la température négative à positive à l'aide du bouton R/F.

DE Schnelle Umschaltung von Minus- auf Plus-Temperatur über R/F-Taste.



# G-CBR12



G-CBR12



# G-CBR22



G-CBR22

- Bacinelle escluse.
- Containers not included.
- Conteneurs exclus.
- Teigbehälter ausgeschossen.

	G-CBR12	G-CBR22
	+1°C / +4°C -18°C / -21°C	
	905 x 700 x 600(h) mm	905 x 700 x 865(h) mm
	675 x 565 x 205(h) mm	675 x 565 x 470(h) mm
	78 L 2x GN1/1 - 150(h) mm	179 L 4x GN1/1 - 150(h) mm
	+43°C / 50%HR	
	ventilata / ventilated	
<b>DEFROST</b>	automatico / automatic	
<b>GAS</b>	R290	
	automatica / automatic	
	elettronico / electronic	
<b>CONTROL</b>	50 mm	
	240 W	460 W
	230V / 50Hz	
<b>MATERIAL</b>	acciaio Inox / stainless steel AISI 304	
<b>REVERSIBLE</b>	no	
	no	
<b>ENERGY CLASS</b>		
	72 Kg	113 Kg
	82 Kg	125 Kg
	975 x 760 x 700(h) mm	975 x 760 x 965(h) mm



## Professional Line

Cassettiere refrigerate con ruote - GN1/1 / Refrigerated Drawer units with wheels - GN1/1  
 Eléments à tiroirs réfrigérés avec roues GN1/1 / Gekühlte Schubladenelemente mit Rädern - GN1/1

# G-CBR13



G-CBR13

# G-CBR23

- Bacinelle escluse.
- Containers not included.
- Conteneurs exclus.
- Teigbehälter ausgeschlossen.



G-CBR23

	G-CBR13	G-CBR23
	+1°C / +4°C -18°C / -22°C	
	1230 x 700 x 600(h) mm	1230 x 700 x 865(h) mm
	1000 x 565 x 205(h) mm	1000 x 565 x 470(h) mm
	116 L 3x GN1/1 - 150(h) mm	265 L 6x GN1/1 - 150(h) mm
	MAX +43°C / 50%HR	
	ventilata / ventilated	
<b>DEFROST</b>	automatico / automatic	
<b>GAS</b>	R290	
	H <sub>2</sub> O automatica / automatic	
	CONTROL elettronico / electronic	
	50 mm	
	270 W	500 W
	1 Ph 230V / 50Hz	
<b>MATERIAL</b>	acciaio Inox / stainless steel AISI 304	
	REVERSIBLE no	
	no	
<b>ENERGY CLASS</b>	<b>E</b>	<b>G</b>
	NET Kg 90 Kg	131 Kg
	GROSS Kg 105 Kg	154 Kg
	1300 x 760 x 700(h) mm	1300 x 760 x 965(h) mm

### G-CBR12

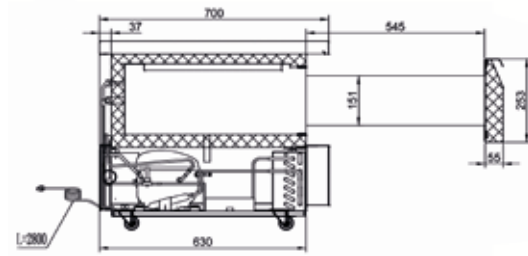
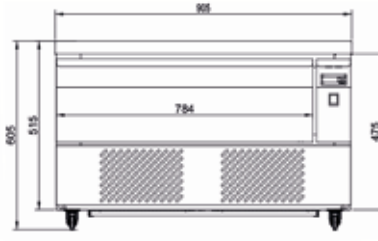
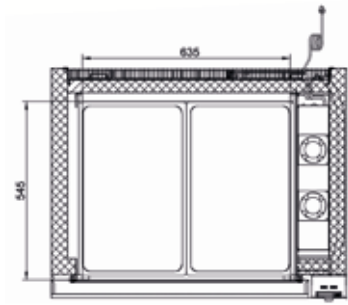

### G-CBR13

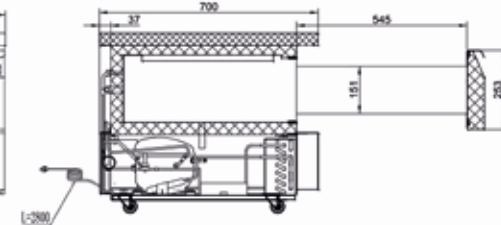
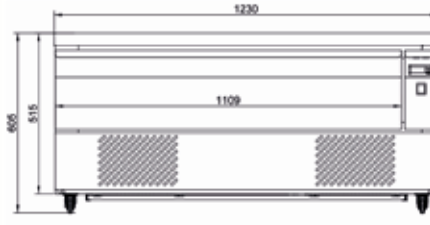
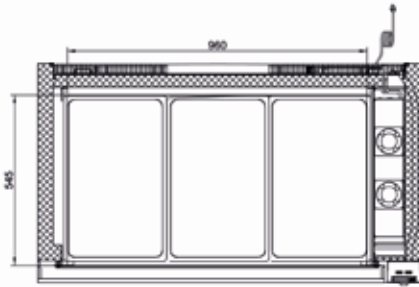

### G-CBR22

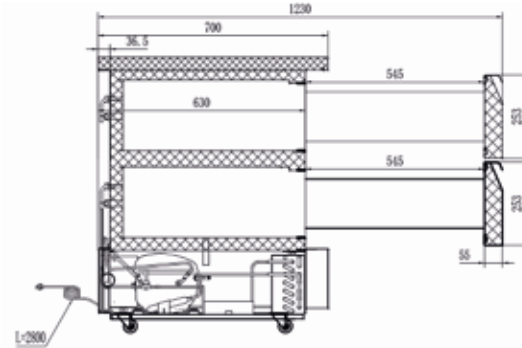
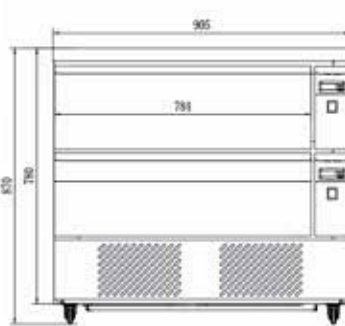
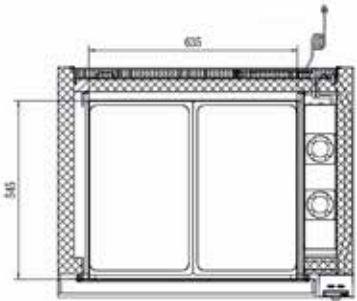

### G-CBR23

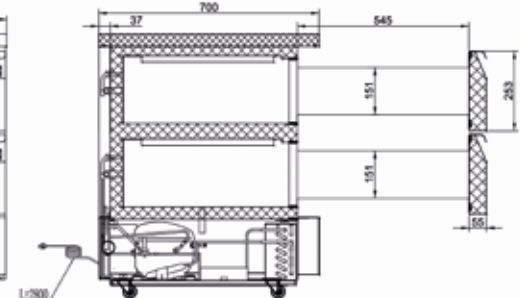
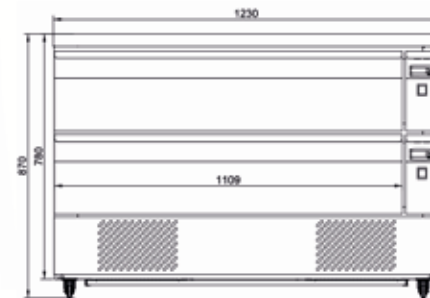
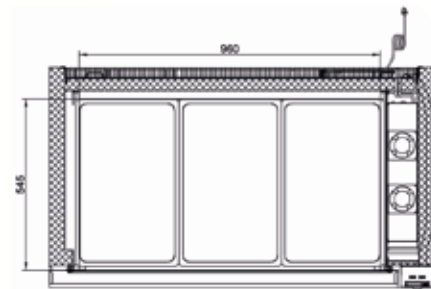

## Professional Line

Cassettiere refrigerate con ruote - GN1/1 / Refrigerated Drawer units with wheels - GN1/1  
Eléments à tiroirs réfrigérés avec roues GN1/1 / Gekühlte Schubladenelemente mit Rädern - GN1/1

# Abbattitori ventilati - Professional Line

IT Abbattitori con struttura monoblocco in acciaio inox AISI 304 - finitura esterna satinata "scotch brite", spessore isolamento 60/70 mm con schiuma alta densità 42 kg/m<sup>3</sup> - piedini regolabili - cella interna con angoli arrotondati per una miglior pulizia - sonda per misurazione temperatura al cuore del prodotto inclusa (solo per abbattimenti positivi) - micro porta per blocco - controllo elettronico della temperatura - evaporazione dell'acqua e sbrinamento manuale per modelli GT3 e GD5A - evaporazione automatica e sbrinamento a caldo per modelli AB. Modello G-T3 con guide adatte per contenere bacinelle GN2/3.

EN Blast chillers with monobloc structure in stainless steel AISI 304 - external satin finish "scotch brite", insulation thickness 60/70 mm with high density foam 42 kg/m<sup>3</sup> - adjustable feet - internal cell with rounded edges for easier cleaning - probe to measure the core temperature of the product included (only for positive chilling) - door microswitch to stop the evaporator fan - electronic temperature control - water evaporation and manual defrosting for models GT3 and GD5A - automatic evaporation and hot-gas defrosting for models AB. Model G-T3 with slides for GN2/3 containers.

FR Cellules de refroidissement rapid avec structure monobloc en acier inox AISI 304 - finition extérieure satinée "scotch brite", épaisseur d'isolation 60/70mm avec mousse à haute densité 42 kg/m<sup>3</sup> - pieds réglables - cellule interne avec coins arrondis pour un meilleur nettoyage - sonde de température au cœur du produit comprise (seulement pour refroidissements positifs) - interrupteur micro porte pour le bloc ventilateur de l'évaporateur - contrôle électronique de température - évaporation d'eau et dégivrage manuel pour modèles GT3 et GD5A - évaporation automatique et dégivrage à gaz chaud pour modèles AB. Modèle G-T3 avec glissières pour bacs GN2/3.

DE Schnellkühler - Monoblockstruktur aus Edelstahl AISI 304, Außenfläche satiniert "Scotch Brite", 60/70 mm Isolationsdicke mit 42 kg/m<sup>3</sup> Hochdichteschäum - verstellbare Füße - Innenzelle mit abgerundeten Ecken zur besseren Reinigung - Fühler zur Temperaturmessung im Kern des Produkts im Lieferumfang enthalten (nur für positive Kühlung), Mikrotürschalter für Verdampfergebläseanhalt - elektronische Temperaturregelung - Wasserverdampfung und manuelle Abtauung für die Modelle GT3 und GD5A - automatische Verdampfung und Heißgasabtauung für die Modelle AB. Modell G-T3 mit Führungsschienen geeignet für Behälter GN2/3.



# G-T3



Ciclo positivo / Positive cycle (90' +70°C > +3°C)
8 Kg
Ciclo negativo / Negative cycle (240' +70°C > -18°C)
5 Kg
Capacità massima teglie Max. trays capacity
3x GN2/3 - 65(h) mm

# G-D5A



Ciclo positivo / Positive cycle (90' +70°C > +3°C)
18 Kg
Ciclo negativo / Negative cycle (240' +70°C > -18°C)
14 Kg
Capacità massima teglie Max. trays capacity
5x 600 x 400 mm GN1/1 - 65(h) mm

	G-T3	G-D5A
	+70°C / +3°C +70°C / -18°C	+90°C / +3°C +90°C / -18°C
	660 x 650 x 420(h) mm	800 x 822 x 1035(h) mm
	360 x 330 x 200(h) mm	660 x 400 x 400(h) mm
	33 L	169 L
	+32°C / 60%HR	+43°C / 60%HR
	ventilata / ventilated	
<b>DEFROST</b>	manuale / manual	
<b>GAS</b>	R290	
	manuale / manual	
	elettronico / electronic	
<b>CONTROL</b>	60 mm	
	500 W	720 W
	230V / 50Hz	
<b>MATERIAL</b>	acciaio Inox / stainless steel AISI 304	
	no	
	no	
<b>STANDARD</b>	3 supporti teglie / trays supports	5 supporti teglie / trays supports
	42 Kg	116 Kg
	52 Kg	159 Kg
	720 x 740 x 570(h) mm	870 x 900 x 1210(h) mm



## Professional Line

Abbattitori / Blast chillers  
Cellules de refroidissement rapide / Schnellkühler

# G-AB1203



Ciclo positivo / Positive cycle (90' +70°C > +3°C)
12 Kg
Ciclo negativo / Negative cycle (240' +70°C > -18°C)
8 Kg
Capacità massima teglie Max. trays capacity
3x 600 x 400 mm GN1/1 - 65(h) mm

# G-AB1805



Ciclo positivo / Positive cycle (90' +70°C > +3°C)
18 Kg
Ciclo negativo / Negative cycle (240' +70°C > -18°C)
14 Kg
Capacità massima teglie Max. trays capacity
5x 600 x 400 mm GN1/1 - 65(h) mm

	G-AB1203	G-AB1805
	+90°C / +3°C +90°C / -18°C	
	800 x 815 x 945(h) mm	800 x 815 x 1015(h) mm
	660 x 400 x 330(h) mm	660 x 400 x 400(h) mm
	140 L	169 L
	+43°C / 60%HR	
	ventilata / ventilated	
<b>DEFROST</b>	gas caldo / hot gas	
<b>GAS</b>	R290	
	automatica / automatic	
	elettronico / electronic	
<b>CONTROL</b>	70 mm	
	700 W	720 W
	230V / 50Hz	
<b>MATERIAL</b>	acciaio Inox / stainless steel AISI 304	
	si / yes	
	no	
<b>STANDARD</b>	3 supporti teglie / trays supports	5 supporti teglie / trays supports
	104 Kg	116 Kg
	140 Kg	159 Kg
	900 x 870 x 1140(h) mm	870 x 900 x 1210(h) mm

# G-AB4010



Ciclo positivo / Positive cycle (90' +70°C > +3°C)
40 Kg
Ciclo negativo / Negative cycle (240' +70°C > -18°C)
28 Kg
Capacità massima teglie Max. trays capacity
10x 600 x 400 mm GN1/1 - 65(h) mm

# G-AB5514



Ciclo positivo / Positive cycle (90' +70°C > +3°C)
50 Kg
Ciclo negativo / Negative cycle (240' +70°C > -18°C)
38 Kg
Capacità massima teglie Max. trays capacity
15x 600 x 400 mm GN1/1 - 65(h) mm

	G-AB4010	G-AB5514
	+90°C / +3°C +90°C / -18°C	
	800 x 815 x 1645(h) mm	800 x 815 x 2170(h) mm
	660 x 400 x 870(h) mm	660 x 400 x 1170(h) mm
	241 L	319 L
	+43°C / 60%HR	
	ventilata / ventilated	
<b>DEFROST</b>	gas caldo / hot gas	
<b>GAS</b>	R290	
	automatica / automatic	
	elettronico / electronic	
<b>CONTROL</b>	70 mm	
	900 W	2500 W
	-	400V / 50Hz
	230V / 50Hz	-
<b>MATERIAL</b>	acciaio Inox / stainless steel AISI 304	
	si / yes	
	no	
<b>STANDARD</b>	10 supporti teglie / trays supports	14 supporti teglie / trays supports
	150 Kg	210 Kg
	200 Kg	236 Kg
	870 x 900 x 1840(h) mm	870 x 900 x 2380(h) mm



## Professional Line

Abbattitori / Blast chillers  
Cellules de refroidissement rapide / Schnellkühler



Sweet Line

# Armadi refrigerati pasticceria ventilati - Sweet Line

**IT** Armadi refrigerati per laboratori di pasticceria. Refrigerazione ventilata - gruppo incorporato - vano motore con fianchi coibentati - evaporatore posizionato a scomparsa in modo da avere il massimo spazio disponibile all'interno - controllo temperatura elettronico con termostato digitale - resistenza elettrica intorno alla cornice porta per eliminazione della condensa - sbrinamento automatico con resistenza elettrica e controllo automatico della temperatura di sbrinamento - evaporazione automatica dell'acqua di condensa - evaporatore trattato anticorrosione. Porta con molla di ritorno e reversibile - chiusura porta con chiave - guarnizione porta estraibile senza utensili - luce interna - fondo con angoli arrotondati - pannelli esterni di fondo e schienale in lamiera galvanizzata. Piedini regolabili in altezza.

**EN** Refrigerated cabinet for pastry shops made. Ventilated refrigeration - incorporated refrigerating unit - insulated engine compartment - concealed evaporator for maximum internal space availability - electronic temperature control with digital thermostat - electrical heating element around the door frame to prevent condensation - automatic defrosting with electric heating element and automatic control of the defrosting temperature - automatic evaporation of the condensate water - anti-corrosion treated evaporator. Reversible door with selfclosing spring - door lock with key - tool-free extractable door gasket - bottom with rounded corners - external back and bottom panels in galvanized plate - height-adjustable feet.

**FR** Armoire réfrigérée pour laboratoires de pâtisserie. Réfrigération ventilée - groupe incorporé - compartiment moteur à parois isolées - évaporateur escamotable pour une plus grande disponibilité d'espace intérieur - régulation électronique de la température avec thermostat digital - résistance électrique autour du cadre de porte pour éliminer la condensation - dégivrage automatique avec résistance électrique et contrôle automatique de la température de dégivrage - évaporation automatique de l'eau condensée - évaporateur traité contre la corrosion. Porte réversible avec ressort auto-fermant - fermeture de la porte par clé - joint de porte extractible sans outils - éclairage intérieur - fond avec coins arrondis - panneaux arrière et inférieur extérieurs en tôle galvanisée. Pieds réglables en hauteur.

**DE** Konditorei Kühlschränke. Umluftkühlung - Motoreinheit eingebaut - isolierter Motorraum - versenkter Verdampfer, um Innenplatz zu gewinnen - elektronische Temperaturregelung mit digitalem Thermostat - elektrischer Heizstab um den Türrahmen herum zur Vermeidung von Kondensation - automatische Abtauung mit elektrischem Heizstab und automatische Steuerung der Abtautemperatur - automatische Kondenswasser-Verdampfung - Verdampfer gegen Korrosion behandelt. Umkehrbare Tür mit Rückholfeder - Türschließung mit Schlüssel - Türdichtung werkzeuglos abnehmbar - Innenbeleuchtung - Boden mit abgerundeten Ecken - Außenrückwand und Bodenplatte aus verzinktem Blech. Höhenverstellbare Füße.

## OPTIONAL

CGPA	GRP68	RUO120	CGGE
	GPA800TN-BT - G-PA800TN-BT-FC		G-GE800BT
-	800 x 600 mm	ø 120 mm	-
Coppia guide per teglie Pair of slides for trays Paire de glissières pour plateaux Paar Führungen für Tablettis	Griglia plastificata Plastic coated grid Grille plastifiée Kunststoffbeschichtetes Gitter	Kit 4 ruote, di cui 2 con freno Set of 4 wheels, 2 with brake Jeu de 4 roues, 2 avec frein Satz mit 4 Rädern, 2 mit Bremse	Coppia guide antiribaltamento per griglia Pair of anti-tilting slides for grid Paire de glissières anti-basculement pour grille Zwei kippssichere Führungsschienen für Gitter

# G-PA800TN G-PA800BT



	G-PA800TN	G-PA800BT
	+2°C / +8°C	-18°C / -22°C
	740 x 990 x 2010(h) mm	
	624 x 846 x 1396(h) mm	
	737 L	
	+32°C / 55%HR	
	ventilata / ventilated	
<b>DEFROST</b>	automatico / automatic	
<b>GAS</b>	R290	
	automatica / automatic	
	elettronico / electronic	
	60 mm	
	330 W	700 W
	230V / 50Hz	
<b>MATERIAL</b>	acciaio Inox / stainless steel AISI 304	
	si / yes	
	si / yes	
<b>STANDARD</b>	10 coppie di guide / pairs of slides ideali per teglie / ideal for trays 600 x 400 mm - 800 x 400 mm	
<b>ENERGY CLASS</b>		
	143 Kg	152 Kg
	169 Kg	178 Kg
	765 x 1015 x 2200(h) mm	

# G-PA800TN-FC G-PA800BT-FC



	G-PA800TN-FC	G-PA800BT-FC
	-2°C / +8°C	-18°C / -22°C
	740 x 990 x 2010(h) mm	
	620 x 860 x 1396(h) mm	
	737 L	
	+35°C / 50%HR	
	ventilata / ventilated	
<b>DEFROST</b>	automatico / automatic	
<b>GAS</b>	R290	
	automatica / automatic	
	elettronico / electronic	
<b>CONTROL</b>	60 mm	
	305 W	591 W
	230V / 50Hz	
<b>MATERIAL</b>	acciaio Inox / stainless steel	
	si / yes	
	si / yes	
<b>STANDARD</b>	10 coppie di guide / pairs of slides ideali per teglie / ideal for trays 600 x 400 mm - 800 x 400 mm	
<b>ENERGY CLASS</b>	<b>D</b>	<b>E</b>
	172 Kg	174 Kg
	182 Kg	184 Kg
	765 x 1015 x 2080(h) mm	

**FORCOLD**  
by flmar

## Sweet Line

Armadi refrigerati pasticceria - ventilati / Refrigerated pastry cabinets - ventilated  
Armoires à pâtisserie réfrigérées - ventilées / Konditorei Kühlchränke - Umluftkühlung

# G-GE800BT



	G-GE800BT
	-10°C / -22°C
	740 x 990 x 2010(h) mm
	624 x 846 x 1396(h) mm
	737 L
	+32°C / 55%HR
	ventilata / ventilated
<b>DEFROST</b>	automatico / automatic
<b>GAS</b>	R290
	automatica / automatic
	elettronico / electronic
<b>CONTROL</b>	60 mm
	700 W
	230V / 50Hz
	1 Ph
<b>MATERIAL</b>	acciaio Inox - stainless steel AISI 304
	si / yes
	si / yes
<b>STANDARD</b>	10 griglie / grids 10 coppie di guide / pairs of slides
<b>ENERGY CLASS</b>	
	162 Kg
	188 Kg
	765 x 1015 x 2200(h) mm



Non include / Not included  
Max. 54 vaschette / containers x 5 L

VG331612

5 L

330 x 165 x 120(h) mm



SCOPRI TUTTI I NOSTRI ACCESSORI SUL CATALOGO MULTISERVICE!  
DISCOVER OUR OPTIONAL ON MULTISERVICE CATALOGUE!

## Sweet Line

Armadi refrigerati pasticceria - ventilati / Refrigerated pastry cabinets - ventilated  
Armoires à pâtisserie réfrigérées - ventilées / Konditorei Kühlchränke - Umluftkühlung

# Tavoli refrigerati pasticceria ventilati - Sweet Line

IT Refrigerazione ventilata. Pannello di controllo elettronico con display digitale - sbrinamento ed evaporazione dell'acqua di sbrinamento automatici - gruppo incorporato estraibile per una facile manutenzione. Porta con guarnizioni magnetiche - angoli interni arrotondati - piedini regolabili - porta con molla di ritorno - schienale in acciaio inox possibilità di appoggiare al muro.

EN Bakery refrigerated. Ventilated refrigeration. Electronic control panel with digital display. Automatic defrosting and evaporation of condensation water. Built-in extractable group for easy maintenance. Door with magnetic gasket - rounded internal corners - height-adjustable feet - door with self-closing spring - stainless steel back panel - can be placed against the wall.

FR Réfrigération ventilée. Panneau de commande électronique avec affichage digital - dégivrage automatique et évaporation de l'eau de dégivrage - groupe extractible intégré pour un entretien facile. Porte avec joints magnétiques - coins intérieurs arrondis - pieds réglables - porte ressort auto-fermant - panneau postérieur en acier inox - peut être placé contre le mur.

DE Umluftkühlung. Elektronisches Bedienfeld mit Digitalanzeige - automatisches Abtauen und Verdampfen des Auftauwassers - eingebaute abnehmbare Gruppe für einfache Wartung. Tür mit Magnetchichtungen - abgerundete Innenecken - verstellbare Füße - Tür mit Rückholfeder - Rückenlehne aus Edelstahl - kann an die Wand gestellt werden.

## OPTIONAL

GUT	GUT70	GAR
G-PA2100-3100-3200-4200TN G-PA2100-3100-3200-4200TN-FC	G-PA1500TNGR7 G-PA2000TNGR7	All models
600 x 400 mm		
Coppia guida per teglie - Pair of tray slides Paire de glissières pour plaque - Führungsschiene für Bleche		Coppia guide antiribaltamento per griglia Pair of anti-tilting slides for grid Paire de glissières anti-basculément pour grille Kippsichere Führungsschienen für Gitter

GRP64	RUO120	RUO120.6
G-PA2100-3100-3200-4200TN G-PA2100-3100-3200-4200TN-FC	G-PA2100-2200TN G-PA2100-2200TN-FC	G-PA3100-3200-4200TN G-PA3100-3200-4200TN-FC
600 x 400 mm	ø120 mm	
Griglia plastificata - Plastic coated grid Grille plastifiée - Kunststoffbeschichtetes Gitter	Kit 4 ruote, di cui 2 con freno - Set of 4 wheels, 2 with brake Jeu de 4 roues, 2 avec frein - Satz mit 4 Rädern, 2 mit Bremse	Kit 6 ruote, di cui 3 con freno - Set of 6 wheels, 3 with brake Jeu de 6 roues, 3 avec frein - Satz mit 6 Rädern, 3 mit Bremse

# G-PA1500TNGR7



- Piano di lavoro in granito
- Granite work surface
- Plan de travail en granit
- Kapazität Schüsseln

# G-PA2000TNGR7



	G-PA1500TNGR7	G-PA2000TNGR7
	+2°C / +8°C	
	1505 x 800 x 870(h) mm	2005 x 800 x 870(h) mm
	1052 x 630 x 589(h) mm	1562 x 630 x 589(h) mm
	390 L	580 L
	+32°C / 55%HR	
	ventilata / ventilated	
<b>DEFROST</b>	automatico / automatic	
<b>GAS</b>	R290	
	automatica / automatic	
	elettronico / electronic	
	60 mm	
	300 W	
	230V / 50Hz	
<b>MATERIAL</b>	acciaio Inox / stainless steel AISI 304	
<b>REVERSIBLE</b>	no	
	no	
<b>STANDARD</b>	7 coppie di guide per porta / pairs of slides for door ideali per teglie / ideal for trays 600 x 400 mm	
<b>ENERGY CLASS</b>	<b>B</b>	<b>C</b>
	242 Kg	300 Kg
	271 Kg	340 Kg
	1550 x 830 x 1040(h) mm	2050 x 830 x 1040(h) mm

Cassetto neutro sopra vano tecnico  
Neutral drawer on technical compartment  
Tiroir neutre sur le compartiment technique  
Neutrale Schublade auf dem Technikraum

# G-PA2100TN



# G-PA3100TN



	G-PA2100TN	G-PA3100TN
	+2°C / +8°C	
	1510 x 800 x 860(h) mm	2020 x 800 x 860(h) mm
	1052 x 630 x 589(h) mm	1562 x 630 x 589(h) mm
	390 L	580 L
	+32°C / 55%HR	
	ventilata / ventilated	
<b>DEFROST</b>	automatico / automatic	
<b>GAS</b>	R290	
	automatica / automatic	
	elettronico / electronic	
	60 mm	
	260 W	
	230V / 50Hz	
<b>MATERIAL</b>	acciaio Inox / stainless steel AISI 304	
	no	
	no	
<b>STANDARD</b>	2 griglie / grids 60x40 cm 2 coppie guide / pairs of slides	3 griglie / grids 60x40 cm 3 coppie guide / pairs of slides
<b>ENERGY CLASS</b>	<b>B</b>	<b>C</b>
	140 Kg	152 Kg
	166 Kg	189 Kg
	1540 x 830 x 1040(h) mm	2050 x 830 x 1040(h) mm



# G-PA2100TN-FC



# G-PA3100TN-FC



	G-PA2100TN-FC	G-PA3100TN-FC
	-2°C / +8°C	
	1510 x 800 x 850(h) mm	2020 x 800 x 850(h) mm
	1052 x 630 x 580(h) mm	1562 x 630 x 580(h) mm
	390 L	580 L
	+35°C / 50%HR	
	ventilata / ventilated	
<b>DEFROST</b>	automatico / automatic	
<b>GAS</b>	R600a	R290
	automatica / automatic	
	elettronico / electronic	
<b>CONTROL</b>	60 mm	
	275 W	398 W
	230V / 50Hz	
<b>MATERIAL</b>	acciaio Inox / stainless steel	
	no	
	no	
<b>STANDARD</b>	2 griglie / grids 60x40 cm 2 coppie di guide / pairs of slides	3 griglie / grids 60x40 cm 3 coppie di guide / pairs of slides
<b>ENERGY CLASS</b>		
	92 Kg	114 Kg
	106 Kg	126 Kg
	1540 x 830 x 880(h) mm	2050 x 830 x 880(h) mm



## Sweet Line

Tavoli refrigerati pasticceria - ventilati / Refrigerated pastry counters - ventilated  
Tables à pâtisserie réfrigérées - ventilées / Konditorei Kühlische - Umluftkühlung

# G-PA2200TN



# G-PA3200TN



	G-PA2200TN	G-PA3200TN
	+2°C / +8°C	
	1510 x 800 x 860/960(h) mm	2020 x 800 x 860/960(h) mm
	1052 x 630 x 589(h) mm	1562 x 630 x 589(h) mm
	390 L	580 L
	+32°C / 55%HR	
	ventilata / ventilated	
<b>DEFROST</b>	automatico / automatic	
<b>GAS</b>	R290	
	automatica / automatic	
	elettronico / electronic	
<b>CONTROL</b>	60 mm	
	260 W	
	230V / 50Hz	
<b>MATERIAL</b>	acciaio Inox / stainless steel AISI 304	
	no	
	no	
<b>STANDARD</b>	2 griglie / grids 60x40 cm 2 coppie di guide / pairs of slides	3 griglie / grids 60x40 cm 3 coppie di guide / pairs of slides
<b>ENERGY CLASS</b>	<b>B</b>	<b>C</b>
	140 Kg	152 Kg
	166 Kg	189 Kg
	1540 x 830 x 1140(h) mm	2050 x 830 x 1140(h) mm



# G-PA2200TN-FC



# G-PA3200TN-FC



	G-PA2200TN-FC	G-PA3200TN-FC
	-2°C / +8°C	
	1510 x 800 x 850/950(h) mm	2020 x 800 x 850/950(h) mm
	1052 x 630 x 580(h) mm	1562 x 630 x 580(h) mm
	390 L	580 L
	+35°C / 50%HR	
	ventilata / ventilated	
<b>DEFROST</b>	automatico / automatic	
<b>GAS</b>	R600a	R290
	automatica / automatic	
	elettronico / electronic	
	60 mm	
	275 W	398 W
	230V / 50Hz	
<b>MATERIAL</b>	acciaio Inox / stainless steel	
	no	
	no	
<b>STANDARD</b>	2 griglie / grids 60x40 cm 2 coppie di guide / pairs of slides	3 griglie / grids 60x40 cm 3 coppie di guide / pairs of slides
<b>ENERGY CLASS</b>		
	92 Kg	114 Kg
	106 Kg	126 Kg
	1540 x 830 x 980(h) mm	2050 x 830 x 980(h) mm



## Sweet Line

Tavoli refrigerati pasticceria - ventilati / Refrigerated pastry counters - ventilated  
Tables à pâtisserie réfrigérées - ventilées / Konditorei Kühlische - Umluftkühlung



# Fast Food & Pizza Line

# Vetrine refrigerate sushi e tapas statiche - Fast Food Line

IT Vetrine refrigerate per sushi e tapas con refrigerazione statica.  
Le vetrine sushi e le vetrine per tapas sono disponibili nel colore nero, la linea Tapas (TS) è a due ripiani - struttura in plastica e vetro - porte scorrevoli in vetro - vetro frontale curvo - illuminazione LED - termostato manuale - bacinelle GN1/3 400(h) mm incluse.

EN Refrigerated display cases for sushi and tapas with static refrigeration.  
The sushi and tapas display cases are available in black, the Tapas (TS) line has two shelves - plastic and glass casing - sliding glass doors - curved front glass - LED lighting - manual thermostat - GN1/3 400(h) mm containers included.

FR Vitrines réfrigérées pour sushis et tapas avec réfrigération statique.  
Les vitrines sushi et tapas sont disponibles en noir, la ligne Tapas (TS) dispose de deux étagères - corps en plastique et verre - portes coulissantes en verre - façade en verre arrondi - éclairage LED - thermostat manuel - GN1/3 400(h) mm bacs inclus.

DE Kühlvitrinen für Sushi und Tapas mit statischer Kühlung.  
Die Sushi- und Tapas-Vitrinen sind in schwarz erhältlich, die Tapas-Linie (TS) hat zwei Einlegeböden - Gehäuse aus Kunststoff und Glas - Glasschiebetüren - gebogenes Frontglas - LED-Beleuchtung - manueller Thermostat - GN1/3 400(h) mm Behälter im Lieferumfang.



# G-SSS1200



4x GN1/3

- Bacinelle comprese
- Containers included

# G-SSS1500



5x GN1/3

- Bacinelle comprese
- Containers included

	G-SSS1200	G-SSS1500
	0°C / +6°C	
	1200 x 415 x 300(h) mm	1500 x 415 x 300(h) mm
	n.4 x GN1/3 - 20 L	n.5 x GN1/3 - 25 L
	+32°C / 60%HR	
	statica / static	
<b>DEFROST</b>	manuale / manual	
<b>GAS</b>	R600a	
	automatica / automatic	
	elettronico / electronic	
	160 W	
	230V / 50Hz	
<b>MATERIAL</b>	vetro / glass + plastica / plastic	
	posteriore scorrevole / sliding back	
	led	
<b>STANDARD</b>	bacinelle / containers 4x GN1/3	bacinelle / containers 5x GN1/3
<b>ENERGY CLASS</b>	<b>B</b>	
	46 kg	51 kg
	62 kg	71 kg
	1281 x 532 x 471(h) mm	1581 x 532 x 471(h) mm

## G-SSS1800



7x GN1/3

- Bacinelle comprese
- Containers included

## G-SSS2000



8x GN1/3

- Bacinelle comprese
- Containers included

	G-SSS1800	G-SSS2000
	0°C / +6°C	
	1800 x 415 x 300(h) mm	2000 x 415 x 300(h) mm
	n.7 x GN1/3 - 36 L	n.8 x GN1/3 - 41 L
	+32°C / 60%HR	
	statica / static	
<b>DEFROST</b>	manuale / manual	
<b>GAS</b>	R600a	
	automatica / automatic	
	elettronico / electronic	
	230 W	
	230V / 50Hz	
<b>MATERIAL</b>	vetro / glass + plastica / plastic	
	posteriore scorrevole / sliding back	
	led	
<b>STANDARD</b>	bacinelle / containers 7x GN1/3	bacinelle / containers 8x GN1/3
<b>ENERGY CLASS</b>	<b>B</b>	<b>C</b>
	61 Kg	71 Kg
	81 Kg	91 Kg
	1881 x 532 x 471(h) mm	2081 x 532 x 471(h) mm



## Fast Food & Pizza Line

Vetrine refrigerate per sushi - statiche / Refrigerated display cases for sushi - static  
Vitrines réfrigérées pour sushis - statiques / Sushi Kühlvitrinen - statischer Kühlung

# G-TS1200



4x GN1/3

- Bacinelle comprese / Containers included
- 2 ripiani / shelves

# G-TS1500



5x GN1/3

- Bacinelle comprese / Containers included
- 2 ripiani / shelves

	G-TS1200	G-TS1500
	+4°C / +8°C	
	1200 x 415 x 330(h) mm	1500 x 415 x 330(h) mm
	n.4 x GN1/3 - 20 L	n.5 x GN1/3 - 25 L
	+32°C / 60%HR	
	statica / static	
<b>DEFROST</b>	manuale / manual	
<b>GAS</b>	R600a	
	automatica / automatic	
	elettronico / electronic	
	160 W	
	230V / 50Hz	
<b>MATERIAL</b>	vetro / glass + plastica / plastic	
	posteriore scorrevole / sliding back	
	led	
<b>STANDARD</b>	bacinelle / containers 4x GN1/3	bacinelle / containers 5x GN1/3
<b>ENERGY CLASS</b>		
	46,5 kg	49 kg
	54 kg	57 kg
	1281 x 532 x 471(h) mm	1581 x 532 x 471(h) mm

# G-TS1800



7x GN1/3

- Bacinelle comprese / Containers included
- 2 ripiani / shelves

# G-TS2000



8x GN1/3

- Bacinelle comprese / Containers included
- 2 ripiani / shelves

	G-TS1800	G-TS2000
	+4°C / +8°C	
	1800 x 415 x 300(h) mm	2000 x 415 x 300(h) mm
	n.7 x GN1/3 - 36 L	n.8 x GN1/3 - 41 L
	+32°C / 60%HR	
	statica / static	
<b>DEFROST</b>	manuale / manual	
<b>GAS</b>	R290	
	automatica / automatic	
	elettronico / electronic	
	230 W	
	230V / 50Hz	
<b>MATERIAL</b>	vetro / glass + plastica / plastic	
	posteriore scorrevole / sliding back	
	led	
<b>STANDARD</b>	bacinelle / containers 7x GN1/3	bacinelle / containers 8x GN1/3
<b>ENERGY CLASS</b>	<b>B</b>	<b>C</b>
	63 Kg	67,5 Kg
	85 Kg	91 Kg
	1881 x 532 x 471(h) mm	2081 x 532 x 471(h) mm



## Fast Food & Pizza Line

Vetrine refrigerate per tapas - statiche / Refrigerated display cases for tapas - static  
Vitrines réfrigérées pour tapas - statiques / Tapas-Kühlvitrinen - statischer Kühlung

# Vetrine refrigerate pizza statiche - Pizza Line



**IT** Vetrine refrigerate pizza con refrigerazione statica. Vetri di protezione - controllo temperatura elettronico - sbrinamento a sosta - gruppo incorporato solo lato destro gas R600a. Adatte per il contenimento di bacinelle gastronorm, inox o in polycarbonato - bacinelle escluse. Disponibili nella Serie 330 o nella Serie 380.

**EN** Refrigerated pizza display cases with static refrigeration. Safety glass - electronic temperature control - stationary defrosting - incorporated motor unit on the right side only - gas R600a. Ideal for gastronorm containers, both in stainless steel or polycarbonate - containers not included. Available with the 330 Line or the 380 Line.

**FR** Vitrines réfrigérées à pizza avec réfrigération statique. Verre de sécurité - régulation électronique de la température - dégivrage par arrête - groupe moteur incorporé à droite uniquement - gaz R600a. Idéal pour les bacs gastronorm, en acier inox ou en polycarbonate - les bacs ne sont pas inclus. Disponible dans la ligne 330 ou la ligne 380.

**DE** Pizza-Kühlvitrinen mit statischer Kühlung. Sicherheitsglas - elektronische Temperaturregelung - Abtauung per Anhalt - eingebautes Aggregat nur auf der rechten Seite - R600a Gas. Ideal für Gastronormbehälter, aus Edelstahl oder Polycarbonat - Behälter sind nicht im Lieferumfang enthalten. Erhältlich mit Linie 330 oder Linie 380.

## Series 330 MAX h 150 mm

L= 1200 mm



L= 1400 mm



L= 1500 mm



L= 1800 mm



















L= 2000 mm



## OPTIONAL

CS330	CSM330
Series 33 (h 100-150-200 mm)	Series 33
Coppia staffe con piedi Pair of brackets with feet Paire de supports avec pieds Paar Halterungen mit Füßen	Coppia di supporti a muro Pair of wall brackets Paire de supports muraux Wandhalterungspaar



	G-RI12033V	G-RI14033V	G-RI15033V	G-RI18033V	G-RI20033V
	+2°C / +8°C				
	1200 x 335 x 230/435(h) mm senza / con vetri without / with glass	1400 x 335 x 230/435(h) mm senza / con vetri without / with glass	1500 x 335 x 230/435(h) mm senza / con vetri without / with glass	1800 x 335 x 230/435(h) mm senza / con vetri without / with glass	2000 x 335 x 230/435(h) mm senza / con vetri without / with glass
	850 x 245 x 150(h) mm	1050 x 245 x 150(h) mm	1150 x 245 x 150(h) mm	1450 x 245 x 150(h) mm	1650 x 245 x 150(h) mm
	5x GN1/4	6x GN1/4	7x GN1/4	9x GN1/4	10x GN1/4
	+32°C / 55%HR				
	statica / static				
<b>DEFROST</b>	automatico / automatic				
<b>GAS</b>	R600a				
	manuale / manual				
	elettronico / electronic				
	45 mm				
	110 W		122 W		
	230V / 50Hz				
<b>MATERIAL</b>	acciaio Inox / stainless steel AISI 304				
	no				
<b>STANDARD</b>	Kit vetri / Glasses set				
					
	42 Kg	50 Kg	50 Kg	56 Kg	59 Kg
	49 Kg	64 Kg	64 Kg	64 Kg	70 Kg
	1290 x 400 x 410(h) mm	1500 x 400 x 410(h) mm	1590 x 400 x 410(h) mm	1890 x 400 x 410(h) mm	2090 x 400 x 410(h) mm

## Fast Food & Pizza Line

Vetrine refrigerate Pizza - statiche / Refrigerated Pizza display cases - static  
Vitrine réfrigérée pour Pizza - statiques / Pizza Kühlvitrine - statisch

# Series 380

## MAX h 150 mm



G-R115038V



G-R118038V

L= 1200 mm

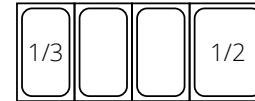

L= 1400 mm



L= 1500 mm

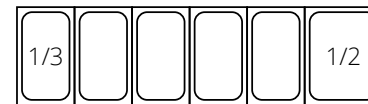

L= 1800 mm

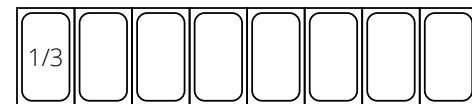

L= 2000 mm

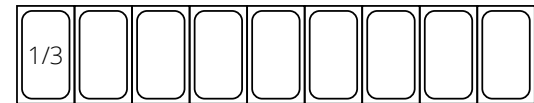

















## OPTIONAL

CS380	CSM380
Series 38 (h 100-150-200 mm)	Series 38
Coppia staffe con piedi Pair of brackets with feet Paire de supports avec pieds Paar Halterungen mit Füßen	Coppia di supporti a muro Pair of wall brackets Paire de supports muraux Wandhalterungspaar



G-R12038V

	G-RI12038V	G-RI14038V	G-RI15038V	G-RI18038V	G-RI20038V
	+2°C / +8°C				
	1200 x 395 x 230/435(h) mm senza / con vetri without / with glass	1400 x 395 x 230/435(h) mm senza / con vetri without / with glass	1500 x 395 x 230/435(h) mm senza / con vetri without / with glass	1800 x 395 x 230/435(h) mm senza / con vetri without / with glass	2000 x 395 x 230/435(h) mm senza / con vetri without / with glass
	850 x 305 x 150(h) mm	1050 x 305 x 150(h) mm	1150 x 305 x 150(h) mm	1450 x 305 x 150(h) mm	1650 x 305 x 150(h) mm
	3x GN1/3 + 1x GN1/2	4x GN1/3 + 1x GN1/2	5x GN1/3 + 1x GN1/2	8x GN1/3	9x GN1/3
	+32°C / 55%HR				
	statica / static				
<b>DEFROST</b>	automatico / automatic				
<b>GAS</b>	R600a				
	manuale / manual				
	elettronico / electronic				
	45 mm				
	110 W		122 W		
	230V / 50Hz				
<b>MATERIAL</b>	acciaio Inox / stainless steel AISI 304				
	no				
<b>STANDARD</b>	Kit vetri / Glasses set				
					
	45 Kg	52 Kg	55 Kg	57 Kg	63 Kg
	53 Kg	66 Kg	69 Kg	70 Kg	75 Kg
	1290 x 460 x 400(h) mm	1490 x 460 x 400(h) mm	1590 x 460 x 400(h) mm	1890 x 460 x 400(h) mm	2090 x 460 x 400(h) mm

## Fast Food & Pizza Line

Vetrine refrigerate Pizza - statiche / Refrigerated Pizza display cases - static  
Vitrine réfrigérée pour Pizza - statiques / Pizza Kühlvitrine - statisch

# Vetrine refrigerate pizza

## statiche - Pizza Line



IT Vetrine refrigerate pizza con refrigerazione statica. Vetri di protezione - gruppo incorporato solo lato destro gas R600a. Adatte per il contenimento di bacinelle gastronorm, inox o in polycarbonato - bacinelle escluse. Disponibili nella Serie 330 o nella Serie 380.

EN Refrigerated pizza display cases with static refrigeration. Safety glass - incorporated motor unit on the right side only - gas R600a. Ideal for gastronorm containers, both in stainless steel or polycarbonate - containers not included. Available with the 330 Line or the 380 Line.

FR Vitrines réfrigérées à pizza avec réfrigération statique. Verre de sécurité - groupe moteur incorporé à droite uniquement - gaz R600a. Idéal pour les bacs gastronorm, en acier inox ou en polycarbonate - les bacs ne sont pas inclus. Disponible dans la ligne 330 ou la ligne 380.

DE Pizza-Kühlvitrinen mit statischer Kühlung. Sicherheitsglas - eingebautes Aggregat nur auf der rechten Seite - R600a Gas. Ideal für Gastronormbehälter, aus Edelstahl oder Polycarbonat - Behälter sind nicht im Lieferumfang enthalten. Erhältlich mit der Serie 330 oder Serie 380.

## Series 330

### MAX 150(h) mm

L= 1200 mm



L= 1400 mm



L= 1500 mm



L= 1800 mm



L= 2000 mm



















## OPTIONAL

CS330	CSM330
Series 33 (h 100-150-200 mm)	Series 33
Coppia staffe con piedi Pair of brackets with feet Paire de supports avec pieds Paar Halterungen mit Füßen	Coppia di supporti a muro Pair of wall brackets Paire de supports muraux Wandhalterungspaar



G-VRX1400-330

	G-VRX1200-330	G-VRX1400-330	G-VRX1500-330	G-VRX1800-330	G-VRX2000-330
	+2°C / +8°C				
	1200 x 335 x 230/435(h) mm senza / con vetri without / with glass	1400 x 335 x 230/435(h) mm senza / con vetri without / with glass	1500 x 335 x 230/435(h) mm senza / con vetri without / with glass	1800 x 335 x 230/435(h) mm senza / con vetri without / with glass	2000 x 335 x 230/435(h) mm senza / con vetri without / with glass
	850 x 245 x 150(h) mm	1050 x 245 x 150(h) mm	1150 x 245 x 150(h) mm	1450 x 245 x 150(h) mm	1650 x 245 x 150(h) mm
	5x GN1/4	6x GN1/4	7x GN1/4	9x GN1/4	10x GN1/4
	+35°C / 50%HR				
	statica / static				
<b>DEFROST</b>	automatico / automatic				
<b>GAS</b>	R600a				
	manuale / manual				
	elettronico / electronic				
	45 mm				
	145 W				
	230V / 50Hz				
<b>MATERIAL</b>	acciaio Inox / stainless steel				
	no				
<b>STANDARD</b>	Kit vetri / Glasses set				
					
	36 Kg	38 Kg	42 Kg	48 Kg	59 Kg
	49 Kg	54 Kg	57 Kg	60 Kg	71 Kg
	1240 x 400 x 430(h) mm	1440 x 400 x 430(h) mm	1540 x 400 x 430(h) mm	1840 x 400 x 430(h) mm	2040 x 400 x 430(h) mm

## Fast Food & Pizza Line

Vetrine refrigerate Pizza - statiche / Refrigerated Pizza display cases - static  
Vitrine réfrigérée pour Pizza - statiques / Pizza Kühlvitrine - statisch

# Series 380

## MAX 150(h) mm



G-VRX1500-380



G-VRX1800-380

L= 1200 mm

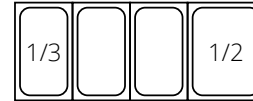

L= 1400 mm

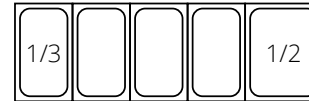

L= 1500 mm

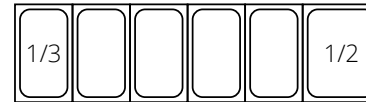

L= 1800 mm



L= 2000 mm

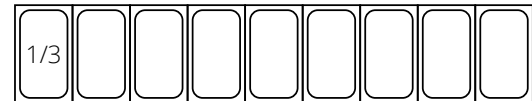

















## OPTIONAL

CS380	CSM380
Series 38 (h 100-150-200 mm)	Series 38
Coppia staffe con piedi Pair of brackets with feet Paire de supports avec pieds Paar Halterungen mit Füßen	Coppia di supporti a muro Pair of wall brackets Paire de supports muraux Wandhalterungspaar



G-VRX1200-380

	G-VRX1200-380	G-VRX1400-380	G-VRX1500-380	G-VRX1800-380	G-VRX2000-380
	+2°C / +8°C				
	1200 x 395 x 230/435(h) mm senza / con vetri without / with glass	1400 x 395 x 230/435(h) mm senza / con vetri without / with glass	1500 x 395 x 230/435(h) mm senza / con vetri without / with glass	1800 x 395 x 230/435(h) mm senza / con vetri without / with glass	2000 x 395 x 230/435(h) mm senza / con vetri without / with glass
	850 x 305 x 150(h) mm	1050 x 305 x 150(h) mm	1150 x 305 x 150(h) mm	1450 x 305 x 150(h) mm	1650 x 305 x 150(h) mm
	3x GN1/3 + 1x GN1/2	4x GN1/3 + 1x GN1/2	5x GN1/3 + 1x GN1/2	8x GN1/3	9x GN1/3
	+35°C / 50%HR				
	statica / static				
<b>DEFROST</b>	automatico / automatic				
<b>GAS</b>	R600a				
	manuale / manual				
	elettronico / electronic				
	45 mm				
	145 W				
	230V / 50Hz				
<b>MATERIAL</b>	acciaio Inox / stainless steel				
	no				
<b>STANDARD</b>	Kit vetri / Glasses set				
					
	38 Kg	42 Kg	43 Kg	52 Kg	61 Kg
	53 Kg	60 Kg	61 Kg	64 Kg	75 Kg
	1290 x 480 x 430(h) mm	1500 x 480 x 430(h) mm	1590 x 480 x 430(h) mm	1890 x 480 x 430(h) mm	2090 x 480 x 430(h) mm

## Fast Food & Pizza Line

Vetrine refrigerate Pizza - statiche / Refrigerated Pizza display cases - static  
Vitrine réfrigérée pour Pizza - statiques / Pizza Kühlvitrine - statisch



# Vetrine refrigerate pizza

## con struttura e coperchio in acciaio inox

### Pizza Line

IT Vetrine refrigerate pizza con refrigerazione statica. Coperchio di protezione per una migliore conservazione del cibo - gruppo incorporato solo lato destro gas R600a. Adatte per il contenimento di bacinelle gastronorm inox o policarbonato - bacinelle escluse. Disponibili nella Serie 330 o nella Serie 380.

EN Pizza refrigerated display cases with static refrigeration. Protective lid for better food preservation - built-in unit on the right side only gas R600a. Ideal for Gastronorm stainless steel or polycarbonate containers - containers not included. Available in 330 or 380 range.

FR Vitrines réfrigérées pour pizzas avec réfrigération statique. Couvercle protecteur pour une meilleure conservation des aliments - unité intégrée uniquement côté droit gaz R600a. Convient pour contenir des bacs gastronorm en acier inox ou en polycarbonate - bacs non inclus. Disponible dans les séries 330 ou 380.

DE Pizza-Kühlvittrinen mit statischer Kühlung. Schutzdeckel für eine bessere Konservierung der Lebensmittel - Einbaueinheit nur rechte Seite Kältemittel R600a. Geeignet für die Aufnahme von Gastronormbehältern aus Edelstahl oder Polycarbonat - Behälter ausgeschlossen. Erhältlich in Serie 330 oder 380.

## Series 330

### MAX 150(h) mm

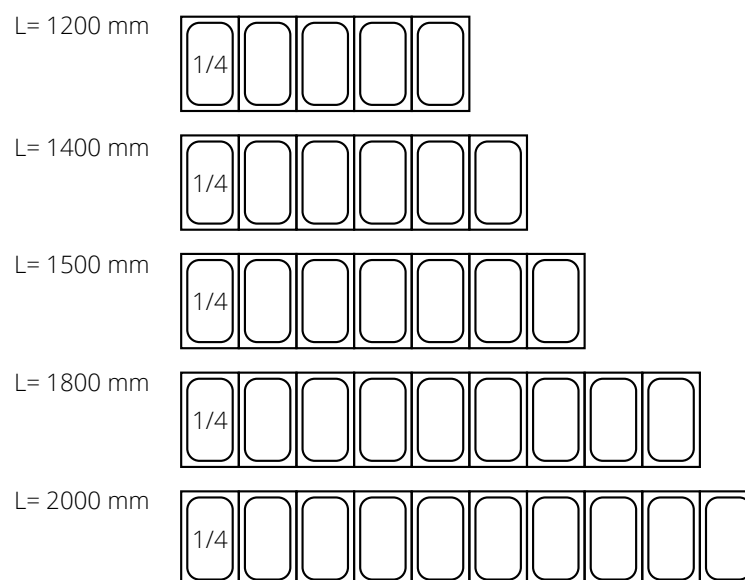

















## OPTIONAL

CS330	CSM330
Series 33 (h 100-150-200 mm)	Series 33
Coppia staffe con piedi Pair of brackets with feet Paire de supports avec pieds Paar Halterungen mit Füßen	Coppia di supporti a muro Pair of wall brackets Paire de supports muraux Wandhalterungspaar



G-VRX1400-330SS

	G-VRX1200-330SS	G-VRX1400-330SS	G-VRX1500-330SS	G-VRX1800-330SS	G-VRX2000-330SS
	+2°C / +8°C				
	1200 x 335 x 285/557(h) mm con coperchio chiuso / aperto with steel closed / open lid	1400 x 335 x 285/557(h) mm con coperchio chiuso / aperto with steel closed / open lid	1500 x 335 x 285/557(h) mm con coperchio chiuso / aperto with steel closed / open lid	1800 x 335 x 285/557(h) mm con coperchio chiuso / aperto with steel closed / open lid	2000 x 335 x 285/557(h) mm con coperchio chiuso / aperto with steel closed / open lid
	5x GN1/4	6x GN1/4	7x GN1/4	9x GN1/4	10x GN1/4
	+35°C / 50%HR				
	statica / static				
<b>DEFROST</b>	automatico / automatic				
<b>GAS</b>	R600a				
	manuale / manual				
	elettronico / electronic				
	45 mm				
	125 W			145 W	
	230V / 50Hz				
<b>MATERIAL</b>	acciaio Inox / stainless steel				
	no				
<b>STANDARD</b>	Kit acciaio inox / Stainless steel set				
					
	32 kg	34 kg	37 kg	43 kg	54 kg
	45 kg	50 kg	52 kg	55 kg	66 kg
	1265 x 400 x 430(h) mm	1465 x 400 x 430(h) mm	1565 x 400 x 430(h) mm	1865 x 400 x 430(h) mm	2065 x 400 x 430(h) mm

## Fast Food & Pizza Line

Vitrine refrigerate Pizza - statiche / Refrigerated Pizza display cases - static  
Vitrine réfrigérée pour Pizza - statiques / Pizza Kühlvitrine - statisch

# Series 380

## MAX 150(h) mm



G-VRX1800-380SS



G-VRX2000-380SS

L= 1200 mm

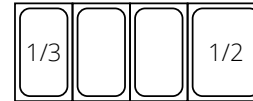

L= 1400 mm

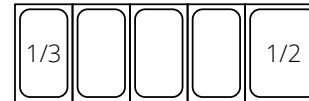

L= 1500 mm

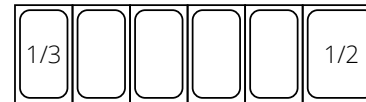

L= 1800 mm

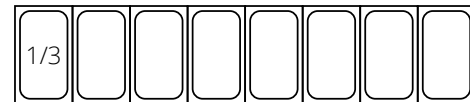

L= 2000 mm

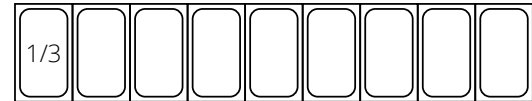

















## OPTIONAL

CS380	CSM380
Series 38 (h 100-150-200 mm)	Series 38
Coppia staffe con piedi Pair of brackets with feet Paire de supports avec pieds Paar Halterungen mit Füßen	Coppia di supporti a muro Pair of wall brackets Paire de supports muraux Wandhalterungspaar



G-VRX1500-380SS

	G-VRX1200-380SS	G-VRX1400-380SS	G-VRX1500-380SS	G-VRX1800-380SS	G-VRX2000-380SS
	+2°C / +8°C				
	1200 x 395 x 285/617(h) mm con coperchio chiuso / aperto with steel closed / open lid	1400 x 395 x 285/617(h) mm con coperchio chiuso / aperto with steel closed / open lid	1500 x 395 x 285/617(h) mm con coperchio chiuso / aperto with steel closed / open lid	1800 x 395 x 285/617(h) mm con coperchio chiuso / aperto with steel closed / open lid	2000 x 395 x 285/617(h) mm con coperchio chiuso / aperto with steel closed / open lid
	3x GN1/3 + 1x GN1/2	4x GN1/3 + 1x GN1/2	5x GN1/3 + 1x GN1/2	8x GN1/3	9x GN1/3
	+35°C / 50%HR				
	statica / static				
<b>DEFROST</b>	automatico / automatic				
<b>GAS</b>	R600a				
	manuale / manual				
	elettronico / electronic				
	45 mm				
	125 W		145 W		
	230V / 50Hz				
<b>MATERIAL</b>	acciaio Inox / stainless steel				
	no				
<b>STANDARD</b>	Kit acciaio inox / Stainless steel set				
					
	35 kg	38 kg	39 kg	47 kg	56 kg
	50 kg	56 kg	57 kg	59 kg	70 kg
	1265 x 480 x 430(h) mm	1465 x 480 x 430(h) mm	1565 x 480 x 430(h) mm	1865 x 480 x 430(h) mm	2065 x 480 x 430(h) mm

## Fast Food & Pizza Line

Vetrine refrigerate Pizza - statiche / Refrigerated Pizza display cases - static  
Vitrine réfrigérée pour Pizza - statiques / Pizza Kühlvitrine - statisch





# Cassettiera inox

## Pizza Line

CAS7  
CAS7-FC



- Cassette pizza escluse - Pizza dough containers not included
- Conteneurs pour pâte exclus - Pizzateigbehälter ausgeschlössen.

	CAS7	CAS7-FC
		
	520 x 800 x 810(h) mm	
<b>MATERIAL</b>	acciaio inox / stainless steel AISI 304	acciaio inox / stainless steel AISI 201
		
	28 Kg	
	30 Kg	
	530 x 810 x 820(h) mm	

- IT Cassettiera inox per contenitori impasti pizza  
600 x 400 x 75(h) mm senza coperchi.
- EN Stainless steel drawers for pizzadough containers  
600 x 400 x 75(h) mm without lids.
- FR Meuble a tiroirs pour conteneurs a pate a pizza  
600 x 400 x 75(h) mm sans couvercles.
- DE Schubladenschrank aus edelstahl fuer pizzateigebhaelter  
600 x 400 x 75(h) mm ohne deckel.

AV4938	AV4939 Coperchio / cover
600 x 400 x 75(h) mm	600 x 400 mm
Contenitore per impasti pizza Pizza dough container Conteneur pour pâte à pizza Pizzateigbehälter	Coperchio - cover couverture - Abdeckung

SCOPRI TUTTI I NOSTRI ACCESSORI SUL CATALOGO MULTISERVICE!  
DISCOVER OUR OPTIONAL ON MULTISERVICE CATALOGUE!



# Banchi pizza refrigerati ventilati - Pizza Line

IT Banchi pizza refrigerati con refrigerazione ventilata. Gruppo incorporato estraibile per facile manutenzione - andamento circolare dell'aria fredda in modo da non investire direttamente il prodotto - controllo temperatura elettronico con termostato digitale - resistenza elettrica intorno alla cornice porta per eliminazione della condensa - sbrinamento automatico con resistenza elettrica e controllo automatico della temperatura di sbrinamento - evaporazione automatica dell'acqua di condensa - evaporatore trattato anticorrosione. Porta con molla di ritorno - guarnizione porta estraibile senza utensili - fondo con angoli arrotondati - piedini regolabili in altezza - schienale in acciaio inox - possibilità di appoggio al muro.

EN Refrigerated pizza counters with ventilated refrigeration. Built-in extractable unit for easy maintenance - circular cold air flow to avoid direct product impact - electronic temperature control with digital thermostat - electrical heating element around the door frame to prevent condensation - automatic defrosting with electrical heating element and automatic defrosting temperature control - automatic evaporation of condensate water - anti-corrosion treated evaporator. Door with self-closing spring - tool-free extractable door gasket - bottom with rounded corners - height-adjustable feet - stainless steel back panel - can be placed against the wall.

FR Comptoirs à pizza réfrigérés avec réfrigération ventilée. Unité extractible intégrée pour un entretien facile - flux d'air froid circulaire pour ne pas affecter directement le produit - régulation électronique de la température avec thermostat digital - résistance électrique autour du cadre de la porte pour éliminer la condensation - dégivrage automatique avec résistance électrique et contrôle automatique de la température de dégivrage - évaporation automatique de l'eau de condensation - évaporateur avec traitement anti-corrosion. Porte avec ressort auto-fermant - joint de porte extractible sans outils - fond avec coins arrondis - pieds réglables en hauteur - panneau arrière en acier inox - possibilité de s'appuyer sur le mur.

DE Pizzakühltische mit Umluftkühlung. Integrierte ausziehbare Einheit für einfache Wartung - runder Kaltluftstrom, um das Produkt nicht direkt zu beeinflussen - elektronische Temperaturregelung mit digitalem Thermostat - elektrischer Heizstab um den Türrahmen herum zur Vermeidung von Kondensation - automatische Abtauung mit elektrischem Heizstab und automatischer Abtautemperaturregelung - automatische Verdampfung des Kondenswassers - Verdampfer gegen Korrosion behandelt. Tür mit Rückholfeder - Türdichtung werkzeuglos abnehmbar - Boden mit abgerundeten Ecken - höhenverstellbare Füße - Rückwand aus Edelstahl - kann an die Wand gestellt werden.

## OPTIONAL

GUT	GAR	GRP64
600 x 400 mm	-	600 x 400 mm
Coppia guida per teglie Pair of tray slides Paire de glissières pour plaque Führungsschiene für Bleche	Coppia guide antiribaltamento per griglia Pair of anti-tilting slides for grid Paire de glissières anti-basculément pour grille Kippsichere Führungsschienen für Gitter	Griglia plastificata Plastic coated grid Grille plastifiée Kunststoffbeschichtetes Gitter

RUO120	RUO120.6	2 KIT RUO120
G-PZ2610-2600TN G-PZ1610-2600TN-FC	G-PZ3600TN G-PZ3600TN-FC	G-PZ2610TN G-PZ2610TN-FC
ø 120 mm		
Kit 4 ruote, di cui 2 con freno - Set of 4 wheels, 2 with brake Jeu de 4 roues, 2 avec frein - Satz mit 4 Rädern, 2 mit Bremse	Kit 6 ruote, di cui 3 con freno - Set of 6 wheels, 3 with brake Jeu de 6 roues, 3 avec frein - Satz mit 6 Rädern, 3 mit Bremse	2x Kit 4 ruote, di cui 2 con freno - Set of 2x4 wheels, 2 with brake Jeu de 2x4 roues, 2 avec frein - Satz mit 2x4 Rädern, 2 mit Bremse

# G-PZ2600TN



NON INCLUSA  
NOT INCLUDED

## Abbinato con / Combined with...

**RI15033V**  
**G-VRX1500-330**  
**G-VRX1500-330SS**  
L= 1500 mm



**RI15038V**  
**G-VRX1500-380**  
**G-VRX1500-380SS**  
L= 1500 mm

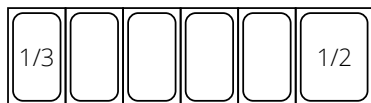

	G-PZ2600TN
	+2°C / +8°C
	1510 x 800 x 1000(h) mm senza vetrina / without display
	1052 x 630 x 589(h) mm
	390 L
	+32°C / 55%HR
	ventilata / ventilated
<b>DEFROST</b>	automatico / automatic
<b>GAS</b>	R290
	automatica / automatic
	elettronico / electronic
<b>CONTROL</b>	50 mm
	260 W
	230V / 50Hz 1 Ph
<b>MATERIAL</b>	acciaio Inox / stainless steel AISI 304
	no
	no
<b>STANDARD</b>	7 coppie guide per porta / pairs of slides for door
<b>ENERGY CLASS</b>	<b>B</b>
	257 Kg
	288 Kg
	1540 x 830 x 1180(h) mm

Cassetto neutro sopra vano tecnico  
Neutral drawer on technical compartment  
Tiroir neutre sur le compartiment technique  
Neutrale Schublade auf dem Technikraum



# G-PZ2600TN-FC



NON INCLUSA  
NOT INCLUDED

## Abbinato con / Combined with...

**RI15033V**  
**G-VRX1500-330**  
**G-VRX1500-330SS**  
L= 1500 mm



**RI15038V**  
**G-VRX1500-380**  
**G-VRX1500-380SS**  
L= 1500 mm

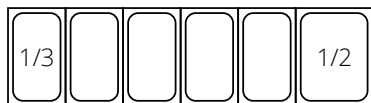

	G-PZ2600TN-FC
	-2°C / +8°C
	1510 x 800 x 1000(h) mm senza vetrina / without display
	1052 x 630 x 580(h) mm
	390 L
	+35°C / 50%HR
	ventilata / ventilated
<b>DEFROST</b>	automatico / automatic
<b>GAS</b>	R600a
	automatica / automatic
	elettronico / electronic
	60 mm
	275 W
	230V / 50Hz 1 Ph
<b>MATERIAL</b>	acciaio Inox / stainless steel
	no
	no
<b>STANDARD</b>	7 coppie guide per porta / pairs of slides for door
<b>ENERGY CLASS</b>	
	252 Kg
	267 Kg
	1540 x 830 x 1180(h) mm

## Fast Food & Pizza Line

Banchi Pizza refrigerati - ventilati / Refrigerated Pizza counters - ventilated  
Comptoirs à Pizza réfrigérés - ventilés / Pizzakühltsche - umluftgekühlt



# G-PZ2610TN



# G-PZ3600TN



NON INCLUSA  
NOT INCLUDED

Abbinato con / Combined with...

RI20033V  
G-VRX2000-330  
G-VRX2000-330SS  
L= 2000 mm



RI20038V  
G-VRX2000-380  
G-VRX2000-380SS  
L= 2000 mm



	G-PZ2610TN	G-PZ3600TN
	+2°C / +8°C	
	2020 x 800 x 1000(h) mm senza vetrina / without display	
	1052 x 630 x 589(h) mm	1562 x 630 x 589(h) mm
	390 L	580 L
	+32°C / 55%HR	
	ventilata / ventilated	
<b>DEFROST</b>	automatico / automatic	
<b>GAS</b>	R290	
	automatica / automatic	
	elettronico / electronic	
	50 mm	
	260 W	
	230V / 50Hz	
<b>MATERIAL</b>	acciaio Inox / stainless steel AISI 304	
<b>REVERSIBLE</b>	no	
	no	
<b>STANDARD</b>	7 coppie guide per porta / pairs of slides for door	
<b>ENERGY CLASS</b>	<b>B</b>	<b>C</b>
<b>NET Kg</b>	362 Kg	320 Kg
<b>GROSS Kg</b>	399 Kg	359 Kg
	2055 x 830 x 1160(h) mm	

Cassetto neutro sopra vano tecnico  
Neutral drawer on technical compartment  
Tiroir neutre sur le compartiment technique  
Neutrale Schublade auf dem Technikraum



# G-PZ2610TN-FC



# G-PZ3600TN-FC



NON INCLUSA  
NOT INCLUDED

Abbinato con / Combined with...

**RI20033V**  
**G-VRX2000-330**  
**G-VRX2000-330SS**  
L = 2000 mm



**RI20038V**  
**G-VRX2000-380**  
**G-VRX2000-380SS**  
L = 2000 mm



	G-PZ2610TN-FC	G-PZ3600TN-FC
	-2°C / +8°C	
	2020 x 800 x 1000(h) mm senza vetrina / without display	
	1052 x 630 x 580(h) mm	1562 x 630 x 580(h) mm
	390 L	580 L
	+35°C / 50%HR	
	ventilata / ventilated	
<b>DEFROST</b>	automatico / automatic	
<b>GAS</b>	R600a	R290
	automatica / automatic	
	elettronico / electronic	
<b>CONTROL</b>	60 mm	
	275 W	398 W
	230V / 50Hz	
<b>1 Ph</b>		
<b>MATERIAL</b>	acciaio Inox / stainless steel	
	no	
<b>REVERSIBLE</b>		
	no	
<b>STANDARD</b>	7 coppie guide per porta / pairs of slides for door	
<b>ENERGY CLASS</b>		
	327 Kg	306 Kg
	347 Kg	326 Kg
	2055 x 830 x 1180(h) mm	

## Fast Food & Pizza Line

Banchi Pizza refrigerati - ventilati / Refrigerated Pizza counters - ventilated  
Comptoirs à Pizza réfrigérés - ventilés / Pizzakühlische - umluftgekühlt

# G-PZ1610TN-FC



NON INCLUSA  
NOT INCLUDED

Abbinato con / Combined with...

**R115033V**  
**G-VRX1500-330**  
**G-VRX1500-330SS**  
L = 1500 mm



**R115038V**  
**G-VRX1500-380**  
**G-VRX1500-380SS**  
L = 1500 mm



	G-PZ1610TN-FC
	-2°C / +8°C
	1510 x 800 x 1000(h) mm senza vetrina / without display
	540 x 630 x 580(h) mm
	221 L
	+35°C / 50%HR
	ventilata / ventilated
<b>DEFROST</b>	automatico / automatic
<b>GAS</b>	R600a
	automatica / automatic
	elettronico / electronic
<b>CONTROL</b>	60 mm
	275 W
	230V / 50Hz 1 Ph
<b>MATERIAL</b>	acciaio Inox / stainless steel
	no
	no
<b>STANDARD</b>	7 coppie guide per porta / pairs of slides for door
<b>ENERGY CLASS</b>	
	304 Kg
	321 Kg
	1540 x 830 x 1180(h) mm

## Fast Food & Pizza Line

Banchi Pizza refrigerati - ventilati / Refrigerated Pizza counters - ventilated  
Comptoirs à Pizza réfrigérés - ventilés / Pizzakühltische - umluftgekühlt

forcar®

# Banchi pizza refrigerati

## statici - Pizza Line

IT Banchi pizza refrigerati con refrigerazione statica. Gruppo incorporato estraibile per facile manutenzione - controllo temperatura elettronico con termostato digitale - resistenza elettrica intorno alla cornice porta per eliminazione della condensa - evaporazione automatica dell'acqua di condensa. Porta con molla di ritorno - guarnizione porta estraibile senza utensili - fondo con angoli arrotondati - piedini regolabili in altezza - schienale in acciaio inox - possibilità di appoggio al muro.

EN Refrigerated pizza counters with static refrigeration. Built-in extractable unit for easy maintenance - electronic temperature control with digital thermostat - electrical heating element around the door frame to prevent condensation - automatic evaporation of condensate water. Door with self-closing spring - tool-free extractable door gasket - bottom with rounded corners - height-adjustable feet - stainless steel back panel - can be placed against the wall.

FR Comptoirs à pizza réfrigérés avec réfrigération statique. Unité extractible intégrée pour un entretien facile - régulation électronique de la température avec thermostat digital - résistance électrique autour du cadre de la porte pour éliminer la condensation - évaporation automatique de l'eau de condensation. Porte avec ressort auto-fermant - joint de porte extractible sans outils - fond avec coins arrondis - pieds réglables en hauteur - panneau arrière en acier inox - possibilité de s'appuyer sur le mur.

DE Pizzakühltische mit statischer Kühlung. Integrierte ausziehbare Einheit für einfache Wartung - elektronische Temperaturregelung mit digitalem Thermostat - elektrischer Heizstab um den Türrahmen herum zur Vermeidung von Kondensation - automatische Verdampfung des Kondenswassers. Tür mit Rückholfeder - Türdichtung werkzeuglos abnehmbar - Boden mit abgerundeten Ecken - höhenverstellbare Füße - Rückwand aus Edelstahl - kann an die Wand gestellt werden.

## OPTIONAL

CG11	GRP11	GRP11-FC
All models	G-S903PZ-PZCAS	G-S903PZ-PZCAS-FC
GN1/1	GN1/1 530 x 325 mm	GN1/1-FC 530 x 333 mm
Coppia guide per griglia - Pair of slides for grid Paire de glissières pour grille - Führungsschienenpaar für Gitterrost	Griglia plastificata - Plastic coated grid Grille plastifiée - Kunststoffbeschichtetes Gitter	

# G-S903PZ



NON INCLUSA  
NOT INCLUDED

Abbinato con / Combined with...

**RI14038V**  
**G-VRX1400380**  
**G-VRX1400380SS**  
L= 1400 mm

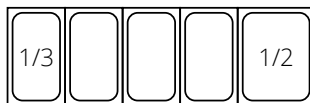

**RI14033V**  
**G-VRX1400330**  
**G-VRX1400330SS**  
L= 1400 mm



	G-S903PZ
	+2°C / +8°C
	1400 x 700 x 1020(h) mm senza vetrina / without display
	1295 x 515 x 500(h) mm
	368 L
	+32°C / 55%HR
	statica / static
DEFROST	automatico / automatic
GAS	R600a
	automatica / automatic
	elettronico / electronic
CONTROL	50 mm
	235 W
	230V / 50Hz 1 Ph
MATERIAL	acciaio Inox / stainless steel AISI 304
	no
	no
STANDARD	3 griglie / grids GN1/1 3 coppie di guide / pairs of slides
ENERGY CLASS	
	170 Kg
	198 Kg
	1430 x 730 x 1275(h) mm

# G-S903PZ-FC



NON INCLUSA  
NOT INCLUDED

## Abbinato con / Combined with...

**G-VRX1400330**  
**G-VRX1400330SS**

L= 1400 mm



**G-VRX1400380**  
**G-VRX1400380SS**

L= 1400 mm



	<b>G-S903PZ-FC</b>
	+2°C / +10°C
	1400 x 700 x 1020(h) mm senza vetrina / without display
	1293 x 515 x 500(h) mm
	368 L
	+35°C / 50%HR
	statica / static
<b>DEFROST</b>	automatico / automatic
<b>GAS</b>	R290
	automatica / automatic
	elettronico / electronic
<b>CONTROL</b>	50 mm
	435 W
	230V / 50Hz 1 Ph
<b>MATERIAL</b>	acciaio Inox / stainless steel
	no
	no
<b>STANDARD</b>	3 griglie / grids GN1/1 3 coppie di guide / pairs of slides
<b>ENERGY CLASS</b>	<b>E</b>
	198 Kg
	223 Kg
	1420 x 750 x 1150(h) mm

## Fast Food & Pizza Line

Banchi Pizza refrigerati - statici / Refrigerated Pizza counters - static  
Comptoirs à Pizza réfrigérés - statiques / Pizzakühlische - statisch

**FORCOLD**  
by finmar

# G-S903PZCAS



- Con cassettera per impasto pizza
- With drawers for pizza dough
- Avec tiroirs pour pâte à pizza
- Mit Schubladen für Pizzateig

NON INCLUSA  
NOT INCLUDED

## Abbinato con / Combined with...

**RI14038V**

**G-VRX1400380**

**G-VRX1400380SS**

L = 1400 mm

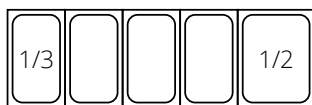

**RI14033V**

**G-VRX1400330**

**G-VRX1400330SS**

L = 1400 mm



	G-S903PZCAS
	+2°C / +8°C
	1400 x 700 x 1020(h) mm senza vetrina / without display
	854 x 530 x 500(h) mm
	257 L
	+32°C / 55%HR
	statica / static
DEFROST	automatico / automatic
GAS	R600a
	automatica / automatic
	elettronico / electronic
CONTROL	45 mm
	155 W
	230V / 50Hz
MATERIAL	acciaio Inox / stainless steel AISI 304
REVERSIBLE	no
	no
STANDARD	2 griglie / grids GN1/1 - 2 coppie di guide / pairs of slides 6 cassetti / drawers
ENERGY CLASS	
	268 Kg
	288 Kg
	1470 x 760 x 1310(h) mm

# G-S903PZCAS-FC



- Con cassetteria per impasto pizza
- With drawers for pizza dough
- Mit Schubladen für Pizzateig
- Avec tiroirs pour pâte à pizza

NON INCLUSA  
NOT INCLUDED

## Abbinato con / Combined with...

**G-VRX1400330**  
**G-VRX1400330SS**

L= 1400 mm



**G-VRX1400380**  
**G-VRX1400380SS**

L= 1400 mm

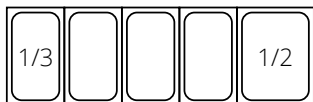

	G-S903PZCAS-FC
	+2°C / +10°C
	1420 x 700 x 1020(h) mm senza vetrina / without display
	827 x 512 x 500(h) mm
	257 L
	+35°C / 50%HR
	statica / static
DEFROST	automatico / automatic
GAS	R600a
	automatica / automatic
	elettronico / electronic
CONTROL	45 mm
	235 W
	230V / 50Hz 1 Ph
MATERIAL	acciaio Inox / stainless steel
REVERSIBLE	no
	no
STANDARD	2 griglie / grids GN1/1 - 2 coppie di guide / pairs of slides 6 cassetti / drawers
ENERGY CLASS	
	198 Kg
	223 Kg
	1440 x 750 x 1150(h) mm

## Fast Food & Pizza Line

Banchi Pizza refrigerati - statici / Refrigerated Pizza counters - static  
Comptoirs à Pizza réfrigérés - statiques / Pizzakühltische - statisch



# Saladette refrigerate per insalate statiche - Fast Food & Pizza Line

IT Saladette refrigerate con refrigerazione statica. Sbrinamento automatico - evaporatore statico schiumato su tre lati con ventola per uniformare la temperatura - coperchio ad apertura telescopica - termostato elettronico - 1 griglia intermedia GN1/1 per porta - bacinelle escluse.

EN Refrigerated saladettes with static refrigeration. Automatic defrosting - static evaporator foamed on three sides with fan to regulate the temperature - lid with telescopic opening - electronic thermostat - 1 intermediate grid GN1/1 per door - containers not included.

DE Saladettes réfrigérées avec réfrigération statique. Dégivrage automatique - évaporateur statique moussé sur trois côtés avec ventilateur pour une température uniforme - couvercle télescopique - thermostat électronique - 1 grille intermédiaire GN1/1 par porte - sans bacs.

FR Gekühlte Saladette mit statischer Kühlung. Automatische Abtauung - statischer Verdampfer dreiseitig geschäumt mit Lüfter für eine gleichmäßige Temperatur - teleskopischer Deckel - elektronischer Thermostat - 1 GN1/1 Zwischengitter pro Tür - ohne Behälter.

## OPTIONAL

CG11	GRPSA	GRP11-FC	RUO50	RUO50-FC	CS12	CS12-FC
All models	G-S400-S900 S902-S903 PS900-PS903 PS200-PS300 S903TOP-SS445BT	G-S900FC-S902FC-S903FC PS900FC-PS903FC-PS200FC PS300FC-S903TOPFC S901S-S901FC S9012DS-S9014DS S9012DFC-S9014DFC	G-S400-S900 S902-S903 PS900-PS903 PS200-PS300 S903TOP-SS445BT	G-S900FC-S902FC-S903FC PS900FC-PS903FC-PS200FC PS300FC-S903TOPFC S901S-S901FC S9012DS-S9014DS S9012DFC-S9014DFC	G-S903TOP G-S903PZ G-PS200 G-PS300	G-S903TOP-FC G-S903PZ-FC
-	570 x 323 mm	530 x 333 mm	ø 50 mm			
Coppia guide per griglia Pair of slides for grid Paire de glissières pour grille Führungsschienenpaar für Gitterrost	Griglia plastificata Plastic coated grid Grille plastifiée Kunststoffbeschichtetes Gitter		Kit 4 ruote con freno Set of 4 wheels with brake Jeu de 4 roues Satz mit 4 Rädern		Set 2 cassette Set 2 drawers Set 2 tiroirs Set 2 Schubfächer	

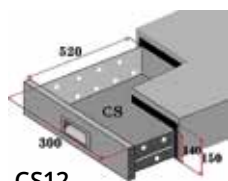

CS12

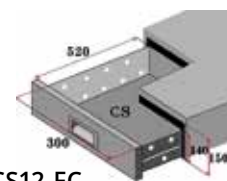

CS12-FC

# G-S400



G-S400

- Con piano in polietilene
- Worktop in polyethylene
- Plan de travail en polyéthylène
- Arbeitsplatte aus Polyethylen

	G-S400
	+2°C / +8°C
	435 x 700 x 870(h) mm
	365 x 595 x 456(h) mm
	109 L
	+30°C / 55%HR
	statica / static
<b>DEFROST</b>	automatico / automatic
<b>GAS</b>	R600a
	automatica / automatic
	elettronico / electronic
	35 mm
	125 W
	230V / 50Hz
<b>MATERIAL</b>	acciaio Inox / stainless steel AISI 304
	no
	no
<b>STANDARD</b>	1 griglia / grid GN1/1 1 coppia di guide / pair of slid
	36 Kg
	41 Kg
	510 x 760 x 1070(h) mm



## Fast Food & Pizza Line

Saladette refrigerate per insalate - statiche / Refrigerated saladettes for salads - static  
Saladettes réfrigérées pour salades - statiques / Gekühlte Saladette für Salate - statisch

# G-S900 - G-S902 G-S903



G-S900 / G-S902

- Con piano in polietilene
- Worktop in polyethylene
- Plan de travail en polyéthylène
- Arbeitsplatte aus Polyethylen



G-S903

	G-S900	G-S902	G-S903
	+2°C / +8°C		
	900 x 700 x 850(h) mm	1045 x 700 x 850(h) mm	1365 x 700 x 850(h) mm
	830 x 530 x 500(h) mm	975 x 530 x 500(h) mm	1295 x 530 x 500(h) mm
	2x GN1/1 + 3x GN1/6 - 240 L	3x GN1/1 - 275 L	4x GN1/1 - 368 L
	+32°C / 55%HR		
	statica / static		
<b>DEFROST</b>	automatico / automatic		
<b>GAS</b>	R600a		
	automatica / automatic		
<b>CONTROL</b>	elettronico / electronic		
	40 mm		
	155 W	175 W	235 W
	230V / 50Hz		
<b>MATERIAL</b>	acciaio Inox / stainless steel AISI 304		
<b>REVERSIBLE</b>	no		
	no		
<b>STANDARD</b>	2 griglie / grids GN1/1 2 coppie di guide / pairs of slides	3 griglie / grids GN1/1 3 coppie guide / pairs of slides	
	70 Kg	80 Kg	107 Kg
	88 Kg	98 Kg	130 Kg
	980 x 760 x 1170(h) mm	1115 x 760 x 1160(h) mm	1390 x 730 x 1160(h) mm

# G-S900-FC - G-S902-FC G-S903-FC



G-S900-FC / G-S902-FC

- Con piano in polietilene
- Worktop in polyethylene
- Plan de travail en polyéthylène
- Arbeitsplatte aus Polyethylen



G-S903-FC

	G-S900-FC	G-S902-FC	G-S903-FC
	+2°C / +10°C		
	900 x 700 x 850(h) mm	1045 x 700 x 850(h) mm	1365 x 700 x 865(h) mm
	827 x 512 x 500(h) mm	972 x 512 x 500(h) mm	1293 x 515 x 500(h) mm
	2x GN1/1 + 3x GN1/6 - 240 L	3x GN1/1 - 302 L	4x GN1/1 - 368 L
	+35°C / 50%HR		
	statica / static		
<b>DEFROST</b>	automatico / automatic		
<b>GAS</b>	R600a	R290	
	automatica / automatic		
<b>CONTROL</b>	elettronico / electronic		
	40 mm		
	235 W	435 W	
	230V / 50Hz		
<b>MATERIAL</b>	acciaio Inox / stainless steel		
<b>REVERSIBLE</b>	no		
	no		
<b>STANDARD</b>	2 griglie / grids GN1/1 2 coppie di guide / pairs of slides	3 griglie / grids GN1/1 3 coppie guide / pairs of slides	
	65 Kg	75 Kg	104 Kg
	79 Kg	89 Kg	116 Kg
	970 x 753 x 900(h) mm	1115 x 753 x 900(h) mm	1390 x 750 x 1100(h) mm

## Fast Food & Pizza Line

Saladette refrigerate per insalate - statiche / Refrigerated saladettes for salads - static  
Saladettes réfrigérées pour salades - statiques / Gekühlte Saladette für Salate - statisch

# G-PS900



- Con piano in granito
- Granite top
- Granitplatte
- Plan de travail en granit

# G-PS903



	G-PS900	G-PS903
	+2°C / +8°C	
	900 x 700 x 1100(h) mm	1365 x 700 x 1100(h) mm
	830 x 515 x 500(h) mm	1295 x 595 x 500(h) mm
	5x GN1/6 - 288 L	8x GN1/6 - 400 L
	+32°C / 55%HR	
	statica / static	
<b>DEFROST</b>	automatico / automatic	
<b>GAS</b>	R600a	
	automatica / automatic	
<b>CONTROL</b>	elettronico / electronic	
	40 mm	
	155 W	235 W
	230V / 50Hz	
<b>MATERIAL</b>	acciaio Inox / stainless steel AISI 304	
<b>REVERSIBLE</b>	no	
	no	
<b>STANDARD</b>	2 griglie / grids GN1/1 2 coppie di guide / pairs of slides	3 griglie / grids GN1/1 3 coppie di guide / pairs of slides
	92 Kg	155 Kg
	120 Kg	175 Kg
	970 x 760 x 1380(h) mm	1390 x 730 x 1264(h) mm

# G-PS900-FC



# G-PS903-FC

- Con piano in granito
- Granite top
- Granitplatte
- Plan de travail en granit



	G-PS900-FC	G-PS903-FC
	+2°C / +10°C	
	900 x 700 x 1075(h) mm	1365 x 700 x 1020(h) mm
	827 x 512 x 500(h) mm	1293 x 515 x 500(h) mm
	5x GN1/6 - 288 L	8x GN1/6 - 400 L
	+35°C / 50%HR	
	statica / static	
<b>DEFROST</b>	automatico / automatic	
<b>GAS</b>	R600a	R290
	automatica / automatic	
<b>CONTROL</b>	elettronico / electronic	
	40 mm	
	235 W	435 W
	230V / 50Hz	
<b>MATERIAL</b>	acciaio Inox / stainless steel	
<b>REVERSIBLE</b>	no	
	no	
<b>STANDARD</b>	2 griglie / grids GN1/1 2 coppie di guide / pairs of slides	3 griglie / grids GN1/1 3 coppie di guide / pairs of slides
	98 Kg	184 Kg
	109 Kg	202 Kg
	970 x 753 x 1100(h) mm	1390 x 750 x 1100(h) mm

## Fast Food & Pizza Line

Saladette refrigerate per insalate - statiche / Refrigerated saladettes for salads - static  
Saladettes réfrigérées pour salades - statiques / Gekühlte Saladette für Salate - statisch

## G-PS200



## G-PS300



	G-PS200	G-PS300
	+2°C / +8°C	
	900 x 700 x 1010(h) mm	1370 x 700 x 1010(h) mm
	830 x 530 x 500(h) mm	1296 x 530 x 500(h) mm
	5x GN1/6 - 254 L	8x GN1/6 - 392 L
	+32°C / 55%HR	
	statica / static	
<b>DEFROST</b>	automatico / automatic	
<b>GAS</b>	R600a	
	automatica / automatic	
	elettronico / electronic	
	40 mm	
	230 W	
	230V / 50Hz	
<b>MATERIAL</b>	acciaio Inox / stainless steel AISI 304	
	no	
	no	
<b>STANDARD</b>	2 griglie / grids GN1/1 2 coppie di guide / pairs of slides	3 griglie / grids GN1/1 3 coppie guide / pairs of slides
	80 Kg	120 Kg
	101 Kg	148 Kg
	970 x 760 x 1280(h) mm	1390 x 730 x 1280(h) mm

## G-PS200-FC



## G-PS300-FC



	G-PS200-FC	G-PS300-FC
	+2°C / + 10°C	
	900 x 700 x 970(h) mm	1365 x 700 x 970(h) mm
	827 x 512 x 500(h) mm	1293 x 515 x 500(h) mm
	5x GN1/6 - 254 L	7x GN1/3 - 392 L
	+35°C / 50%HR	
	statica / static	
<b>DEFROST</b>	automatico / automatic	
<b>GAS</b>	R600a	R290
	automatica / automatic	
<b>CONTROL</b>	elettronico / electronic	
	40 mm	
	235 W	435 W
	230V / 50Hz	
<b>MATERIAL</b>	acciaio Inox / stainless steel	
<b>REVERSIBLE</b>	no	
	no	
<b>STANDARD</b>	2 griglie / grids GN1/1 2 coppie di guide / pairs of slides	3 griglie / grills GN1/1 3 coppie di guide / pairs of slides
<b>NET Kg</b>	72 Kg	120 Kg
<b>GROSS Kg</b>	87 Kg	141 Kg
	970 x 750 x 985(h) mm	1390 x 750 x 985(h) mm

## Fast Food & Pizza Line

Saladette refrigerate per insalate - statiche / Refrigerated saladettes for salads - static  
Saladettes réfrigérées pour salades - statiques / Gekühlte Saladette für Salate - statisch

# G-S901S



# G-S903TOP



	G-S901S	G-S903TOP
	+2°C / +8°C	
	900 x 700 x 860(h) mm	1365 x 700 x 860(h) mm
	830 x 530 x 500(h) mm	1295 x 530 x 500(h) mm
	240 L	368 L
	+32°C / 55%HR	
	statica / static	
<b>DEFROST</b>	automatico / automatic	
<b>GAS</b>	R600a	
	automatica / automatic	
	elettronico / electronic	
	40 mm	
	155 W	235 W
	230V / 50Hz	
<b>MATERIAL</b>	acciaio Inox / stainless steel AISI 304	
	no	
	no	
<b>STANDARD</b>	2 griglie / grids GN1/1 2 coppie di guide / pairs of slides	3 griglie / grids 3 coppie di guide / pairs of slides
<b>ENERGY CLASS</b>	<b>E</b>	<b>C</b>
	72 Kg	110 Kg
	90 Kg	138 Kg
	978 x 760 x 1170(h) mm	1390 x 730 x 1170(h) mm

## G-S901-FC



## G-S903TOP-FC



	G-S901-FC	G-S903TOP-FC
	+2°C / +10°C	
	900 x 700 x 880(h) mm	1365 x 700 x 880(h) mm
	827 x 512 x 500(h) mm	1293 x 515 x 500(h) mm
	240 L	368 L
	+35°C / 50%HR	
	statica / static	
<b>DEFROST</b>	automatico / automatic	
<b>GAS</b>	R600a	R290
	automatica / automatic	
	elettronico / electronic	
	40 mm	
	235 W	
	230V / 50Hz	
<b>MATERIAL</b>	acciaio Inox / stainless steel	
<b>REVERSIBLE</b>	no	
	no	
<b>STANDARD</b>	2 griglie / grids GN1/1 2 coppie di guide / pairs of slides	3 griglie / grids GN1/1 3 coppie di guide / pairs of slides
<b>ENERGY CLASS</b>		
<b>NET Kg</b>	65 Kg	110 Kg
<b>GROSS Kg</b>	79 Kg	122 Kg
	970 x 753 x 900(h) mm	1390 x 750 x 900(h) mm

## Fast Food & Pizza Line

Saladette refrigerate per insalate - statiche / Refrigerated saladettes for salads - static  
Saladettes réfrigérées pour salades - statiques / Gekühlte Saladette für Salate - statisch

# G-SS45BT



	G-SS45BT
	-12°C / -18°C
	943 x 700 x 860(h) mm
	810 x 530 x 500(h) mm
	240 L
	+32°C / 55%HR
	statica / static
<b>DEFROST</b>	automatico / automatic
<b>GAS</b>	R290
	automatica / automatic
	elettronico / electronic
	55 mm
	260 W
	230V / 50Hz
<b>MATERIAL</b>	acciaio Inox / stainless steel AISI 304
	no
	no
<b>STANDARD</b>	2 griglie / grids GN1/1 2 coppie di guide / pairs of slides
<b>ENERGY CLASS</b>	
	86 Kg
	103 Kg
	1010 x 773 x 1160(h) mm



## Fast Food & Pizza Line

Saladette refrigerate per insalate - statiche / Refrigerated saladettes for salads - static  
Saladettes réfrigérées pour salades - statiques / Gekühlte Saladette für Salate - statisch

## G-S9012DS



## G-S9014DS



	G-S9012DS	G-S9014DS
	+2°C / +8°C	
	900 x 700 x 860(h) mm	
	340 x 530 x 500(h) mm + 2 cassetti drawers 300 x 510 x 140(h) mm	340 x 530 x 500(h) mm + 4 cassetti drawers 300 x 510 x 140(h) mm
	240 L	
	+32°C / 55%HR	
	statica / static	
<b>DEFROST</b>	automatico / automatic	
<b>GAS</b>	R600a	
	automatica / automatic	
<b>CONTROL</b>	elettronico / electronic	
	40 mm	
	155 W	
	230V / 50Hz	
<b>MATERIAL</b>	acciaio Inox / stainless steel AISI 304	
<b>REVERSIBLE</b>	no	
	no	
<b>STANDARD</b>	1 griglia / grids GN1/1 1 coppia di guide / pair of slid + 2 cassetti / drawers	4 cassetti / drawers
<b>ENERGY CLASS</b>		
<b>NET Kg</b>	81 Kg	89 Kg
<b>GROSS Kg</b>	98 Kg	106 Kg
	978 x 760 x 1170(h) mm	

## G-S9012D-FC



## G-S9014D-FC



	G-S9012D-FC	G-S9014D-FC
	+2°C / +10°C	
	900 x 700 x 880(h) mm	
	340 x 530 x 500(h) mm + 2 cassetti drawers 300 x 510 x 140(h) mm	340 x 530 x 500(h) mm + 4 cassetti drawers 300 x 510 x 140(h) mm
	240 L	
	+35°C / 50%HR	
	statica / static	
<b>DEFROST</b>	automatico / automatic	
<b>GAS</b>	R600a	
	automatica / automatic	
<b>CONTROL</b>	elettronico / electronic	
	40 mm	
	235 W	
	230V / 50Hz	
<b>MATERIAL</b>	acciaio Inox / stainless steel	
<b>REVERSIBLE</b>	no	
	no	
<b>STANDARD</b>	1 griglia / grids GN1/1 1 coppia di guide / pair of slid 2 cassetti / drawers	4 cassetti / drawers
<b>ENERGY CLASS</b>		
<b>NET Kg</b>	71 Kg	80 Kg
<b>GROSS Kg</b>	89 Kg	98 Kg
	970 x 753 x 900(h) mm	

## Fast Food & Pizza Line

Saladette refrigerate per insalate - statiche / Refrigerated saladettes for salads - static  
Saladettes réfrigérées pour salades - statiques / Gekühlte Saladette für Salate - statisch



Eco Line

# Armadi refrigerati ventilati - Eco Line



IT Armadi refrigerati ECOVENT con refrigerazione ventilata. Struttura esterna in lamiera verniciata epossidica bianca o in acciaio inox AISI 430 - interno in PS - pannelli esterni di fondo e retro in lamiera zincata.

EN ECOVENT refrigerated cabinets with ventilated refrigeration. External casing in white epoxy painted plate or in stainless steel AISI 430 - internal casing in PS - external bottom and back panels in galvanised plate.

FR Armoires réfrigérées ECOVENT avec réfrigération ventilée. Structure externe en tôle peinte à l'époxy blanc ou en acier inox AISI 430 - intérieur en PS - panneaux extérieurs de fond et arrière en tôle galvanisée.

DE ECOVENT-Kühlschränke mit Umluftkühlung. Außengehäuse aus weißem, epoxidharzlackiertem Blech oder Edelstahl AISI 430 - innen aus PS - Außenboden und Rückwand aus verzinktem Blech.

## OPTIONAL

GRP400ECO	GRP402ECO	GRP600ECO	GRP602ECO
G-ERV400-400SS - G-ERV400G-400GSS G-EFV400-400SS - G-EFV400G-400GSS		G-ERV600-600SS - G-ERV600G-600GSS G-EFV600-600SS - G-EFV600G-600GSS	
475 x 377 mm	475 x 147 mm	650 x 527 mm	650 x 297 mm
Griglia plastificata - Plastic coated grid - Grille plastifiée - Kunststoffbeschichtetes Gitter			

# G-ERV400 - G-EFV400 G-ERV400SS - G-EFV400SS



G-ERV400



G-EFV400SS

## STANDARD

### G-ERV400 - G-ERV400SS

3 griglie/grids 475 x 377 mm  
1 griglia inferiore/bottom grid  
475 x 147 mm

### G-EFV400 - G-EFV400SS

4 griglie/grids 475 x 377 mm  
1 griglia inferiore/bottom grid  
475 x 147 mm

	G-ERV400	G-EFV400	G-ERV400SS	G-EFV400SS
	0°C / +8°C	-18°C / -22°C	0°C / +8°C	-18°C / -22°C
	600 x 600 x 1860(h) mm			
	460 x 460 x 1627(h) mm			
	279 L			
	+35°C / 65%HR			
	ventilata / ventilated			
<b>DEFROST</b>	automatico / automatic			
<b>GAS</b>	R600a	R290	R600a	R290
	automatica / automatic			
<b>CONTROL</b>	elettronico / electronic			
	70 mm			
	210 W	390 W	210 W	390 W
	230V / 50Hz			
<b>MATERIAL</b>	lamiera verniciata / painted tin plate - PS		acciaio Inox / stainless steel AISI 430 - PS	
<b>REVERSIBLE</b>	si / yes			
	no			
<b>ENERGY CLASS</b>				
	73 Kg	82 Kg	78 Kg	88 Kg
	85 Kg	94 Kg	90 Kg	100 Kg
	630 x 660 x 2003(h) mm			

# G-ERV600 - G-EFV600 G-ERV600SS - G-EFV600SS



G-ERV600



G-EFV600SS

## STANDARD

### G-ERV600 - G-ERV600SS

3 ripiani / shelves 650 x 527 mm  
+ 1 ripiano / shelf 650 x 297 mm

### G-EFV600 - G-EFV600SS

4 ripiani / shelves 650 x 527 mm  
+ 1 ripiano / shelf 650 x 297 mm

	G-ERV600	G-EFV600	G-ERV600SS	G-EFV600SS
	0°C / +8°C	-18°C / -22°C	0°C / +8°C	-18°C / -22°C
	775 x 750 x 1860(h) mm			
	635 x 460 x 1627(h) mm			
	509 L			
	+35°C / 65%HR			
	ventilata / ventilated			
<b>DEFROST</b>	automatico / automatic			
<b>GAS</b>	R600a	R290	R600a	R290
	automatica / automatic			
<b>CONTROL</b>	elettronico / electronic			
	70 mm			
	280 W	480 W	280 W	480 W
	230V / 50Hz			
<b>MATERIAL</b>	lamiera verniciata / painted tin plate - PS		acciaio Inox / stainless steel AISI 430 - PS	
<b>REVERSIBLE</b>	si / yes			
	no			
<b>ENERGY CLASS</b>				
	92 Kg	102 Kg	98 Kg	108 Kg
	112 Kg	122 Kg	118 Kg	128 Kg
	805 x 815 x 2003(h) mm			

## Eco Line

Armadi refrigerati - ventilati / Refrigerated cabinets - ventilated  
Armoires réfrigérées - ventilées / Kühlschränke - Umluftkühlung

# G-ERV400G - G-EFV400G G-ERV400GSS - G-EFV400GSS



G-EFV400G



G-ERV400GSS

## STANDARD

### G-ERV400G - G-ERV400GSS

3 ripiani / shelves 475 x 377 mm  
+ 1 ripiano / shelf 475 x 147 mm

### G-EFV400G - G-EFV400GSS

4 ripiani / shelves 475 x 377 mm  
+ 1 ripiano / shelf 475 x 147 mm

	G-ERV400G	G-EFV400G	G-ERV400GSS	G-EFV400GSS
	0°C / +8°C	-18°C / -22°C	0°C / +8°C	-18°C / -22°C
	600 x 600 x 1860(h) mm			
	460 x 460 x 1627(h) mm			
	300 L			
	+30°C / 55%HR			
	ventilata / ventilated			
<b>DEFROST</b>	automatico / automatic			
<b>GAS</b>	R600a	R290	R600a	R290
	automatica / automatic			
<b>CONTROL</b>	elettronico / electronic			
	70 mm			
	210 W	530 W	210 W	530 W
	230V / 50Hz			
<b>MATERIAL</b>	lamiera verniciata / painted tin plate PS + vetrocamera / insulating glass		acciaio Inox / stainless steel AISI 430 PS + vetrocamera / insulating glass	
<b>REVERSIBLE</b>	no			
	si / yes			
<b>ENERGY CLASS</b>				
<b>NET Kg</b>	86 Kg	96 Kg	91 Kg	103 Kg
<b>GROSS Kg</b>	98 Kg	108 Kg	103 Kg	115 Kg
	630 x 660 x 2003(h) mm			

# G-ERV600G - G-EFV600G G-ERV600GSS - G-EFV600GSS



G-ERV600G

G-EFV600GSS

## STANDARD

### G-ERV600G - G-ERV600GSS

3 ripiani / shelves 650 x 527 mm  
+ 1 ripiano / shelf 650 x 297 mm

### G-EFV600G - G-EFV600GSS

4 ripiani / shelves 650 x 527 mm  
+ 1 ripiano / shelf 650 x 297 mm

	G-ERV600G	G-EFV600G	G-ERV600GSS	G-EFV600GSS
	0°C / +8°C	-18°C / -22°C	0°C / +8°C	-18°C / -22°C
	775 x 750 x 1860(h) mm			
	635 x 460 x 1627(h) mm			
	538 L			
	+30°C / 55%HR			
	ventilata / ventilated			
<b>DEFROST</b>	automatico / automatic			
<b>GAS</b>	R600a	R290	R600a	R290
	automatica / automatic			
<b>CONTROL</b>	elettronico / electronic			
	70 mm			
	280 W	480 W	280 W	630 W
	230V / 50Hz			
<b>MATERIAL</b>	lamiera verniciata / painted tin plate PS + vetrocamera / insulating glass		acciaio Inox / stainless steel AISI 430 PS + vetrocamera / insulating glass	
<b>REVERSIBLE</b>	no			
	si / yes			
<b>ENERGY CLASS</b>				
	110 Kg		115 Kg	
	130 Kg		135 Kg	
	805 x 815 x 2003(h) mm			

## Eco Line

Armadi refrigerati - ventilati / Refrigerated cabinets - ventilated  
Armoires réfrigérées - ventilées / Kühlschränke - Umluftkühlung

# Armadi refrigerati statici - Eco Line

IT Armadi refrigerati con refrigerazione statica. Struttura esterna in lamiera verniciata epossidica bianca o in acciaio inox AISI 430 - interno ABS - refrigerazione statica con ventilatore interno per uniformare la temperatura - pannelli esterni di fondo e retro in lamiera zincata - resistenza sulla porta per i modelli in vetro.

EN Refrigerated cabinets with static refrigeration. External casing in white epoxy-coated plate or stainless steel AISI 430 - inside ABS - static refrigeration with internal fan for uniform temperature - external back and bottom panels in galvanised plate - heating element on door for glass models.

FR Armoires réfrigérées avec réfrigération statique. Corps extérieur en tôle époxy blanche ou en acier inox AISI 430 - intérieur en ABS - réfrigération statique avec ventilateur interne pour uniformiser la température - panneaux extérieurs arrière et inférieur en tôle galvanisée - résistance sur la porte pour les modèles en verre.

DE Kühlschränke mit statischer Kühlung. Äußeres Gehäuse aus weißem, epoxidharzlackiertem Blech oder Edelstahl AISI 430 - Innenraum aus ABS - statische Kühlung mit internem Gebläse zum Temperatur-ausgleich - äußere Rückwand und Boden aus verzinktem Blech - Heiz-stab an der Tür bei den Modellen mit Glas.

## OPTIONAL

GRP200	GRP400	GRP600	GRP600P
G-ER200-200SS - G-ER200G-200GSS G-ER400-400SS - G-ER400G-400GSS		G-ER600-600SS - G-ER600G-600GSS	
505 x 215 mm	505 x 415 mm	650 x 520 mm	650 x 290 mm
Griglia plastificata - Plastic coated grid - Grille plastifiée - Kunststoffbeschichtetes Gitter			

CG500	GRI64
G-ER500P - G-ER500PSS	
600 x 400 mm	
Coppia guide per teglia - Pair of slides for pans Paire de glissières pour plaques - Führungsschienen	Griglia inox - Stainless steel grid Grille acier inox - Edelstahlgitter

# G-ER200 - G-EF200 G-ER200SS - G-EF200SS



G-ER200

G-ER200SS

## STANDARD

### G-ER200 - G-ER200SS

2 griglie / grids 505 x 415 mm  
1 griglia / grid 505 x 215 mm

### G-EF200 - G-EF200SS

2 ripiani fissi / fixed shelves  
480 x 440 mm

	G-ER200	G-EF200	G-ER200SS	G-EF200SS
	+2°C / +8°C	-18°C / -22°C	+2°C / +8°C	-18°C / -22°C
	600 x 585 x 855(h) mm			
	510 x 485 x 620(h) mm			
	130 L			
	+32°C / 55%HR			
	evaporatore a piastra / plate evaporator	evaporatore a ripiani / shelves evaporator	evaporatore a piastra / plate evaporator	evaporatore a ripiani / shelves evaporator
DEFROST	automatico automatic	manuale manual	automatico automatic	manuale manual
GAS	R600a			
	automatica / automatic			
CONTROL	termostato / thermostat			
	40 mm	60 mm	40 mm	60 mm
	100 W	105 W	100 W	105 W
	230V / 50Hz			
MATERIAL	lamiera verniciata / painted tin plate - ABS		acciaio Inox / stainless steel AISI 430 - ABS	
REVERSIBLE	si / yes			
	no			
ENERGY CLASS	<b>A</b>	-	<b>A</b>	-
	45 Kg	45 Kg	44 Kg	45 Kg
	56 Kg	57 Kg	56 Kg	57 Kg
	680 x 650 x 1160(h) mm			

## Eco Line

Armadi refrigerati - statici / Refrigerated cabinets - static  
Armoires réfrigérées - statiques / Kühlschränke - statische Kühlung

# G-ER400 - G-EF400 G-ER400SS - G-EF400SS



G-ER400

G-ER400SS

## STANDARD

### G-ER400 - G-ER400SS

3 griglie / grids 505 x 415 mm  
+ 1 griglia / grid 505 x 215 mm

### G-EF400 - G-EF400SS

6 ripiani fissi / fixed shelves  
480 x 440 mm

	G-ER400	G-EF400	G-ER400SS	G-EF400SS
	+2°C / +8°C	-18°C / -22°C	+2°C / +8°C	-18°C / -22°C
	600 x 585 x 1855(h) mm			
	510 x 485 x 1620(h) mm			
	340 L			
	+32°C / 55%HR			
	evaporatore a piastra / plate evaporator	evaporatore a ripiani / shelves evaporator	evaporatore a piastra / plate evaporator	evaporatore a ripiani / shelves evaporator
DEFROST	automatico automatic	manuale manual	automatico automatic	manuale manual
GAS	R600a			
	automatica / automatic			
CONTROL	termostato / thermostat			
	45 mm	60 mm	45 mm	60 mm
	150 W	185 W	150 W	185 W
	230V / 50Hz			
MATERIAL	lamiera verniciata / painted tin plate - ABS		acciaio Inox / stainless steel AISI 430 - ABS	
REVERSIBLE	si / yes			
	no			
ENERGY CLASS		-		-
NET Kg	69 Kg	74 Kg	69 Kg	74 Kg
GROSS Kg	81 Kg	86 Kg	81 Kg	86 Kg
	680 x 650 x 2210(h) mm			

# G-ER600 - G-EF600 G-ER600SS - G-EF600SS



G-ER600

G-ER600SS

## STANDARD

### G-ER600 - G-ER600SS

3 griglie / grids 650 x 520 mm  
+ 1 griglia / grid 650 x 290 mm

### G-EF600 - G-EF600SS

6 ripiani fissi / fixed shelves  
650 x 500 mm

	G-ER600	G-EF600	G-ER600SS	G-EF600SS
	+2°C / +8°C	-18°C / -22°C	+2°C / +8°C	-18°C / -22°C
	777 x 695 x 1895(h) mm			
	657 x 580 x 1660(h) mm			
	570 L			
	+32°C / 55%HR			
	evaporatore a piastra / plate evaporator	evaporatore a ripiani / shelves evaporator	evaporatore a piastra / plate evaporator	evaporatore a ripiani / shelves evaporator
DEFROST	automatico automatic	manuale manual	automatico automatic	manuale manual
GAS	R600a			
	automatica / automatic			
CONTROL	termostato / thermostat			
	60 mm			
	185 W	300 W	185 W	300 W
	230V / 50Hz			
MATERIAL	lamiera verniciata / painted tin plate - ABS		acciaio Inox / stainless steel AISI 430 - ABS	
REVERSIBLE	si / yes			
	no			
ENERGY CLASS		-		-
	90 Kg	94 Kg	90 Kg	94 Kg
	107 Kg	111 Kg	107 Kg	111 Kg
	840 x 760 x 2210(h) mm			

## Eco Line

Armadi refrigerati - statici / Refrigerated cabinets - static  
Armoires réfrigérées - statiques / Kühlschränke - statische Kühlung

# G-EF600CAS G-EF600SSCAS



<b>HF600.60</b>
cassetta - container
515 x 310 x 175(h) mm
18 Kg

	G-EF600CAS	G-EF600SSCAS
	-18°C / -22°C	
	777 x 695 x 1895(h) mm	
	657 x 580 x 1660(h) mm	
	570 L	
	+32°C / 55%HR	
	evaporatore a ripiani / shelves evaporator	
<b>DEFROST</b>	manuale / manual	
<b>GAS</b>	R600a	
	automatica / automatic	
	termostato / thermostat	
	60 mm	
	300 W	
	230V / 50Hz	
<b>MATERIAL</b>	lamiera verniciata / painted tin plate - ABS	acciaio Inox / stainless steel AISI 430 - ABS
<b>REVERSIBLE</b>	si / yes	
	no	
<b>STANDARD</b>	6 ripiani fissi e 13 cassette fixed shelves + 13 containers	
	94 Kg	
	111 Kg	
	840 x 760 x 2210(h) mm	

# G-ER200G - G-EF200G G-ER200GSS - G-EF200GSS



G-ER200G

G-ER200GSS

**B**  
NERO / BLACK  
pag. 206

## STANDARD

**G-ER200G - G-ER200GSS**

2 griglie / grids 505 x 415 mm  
+ 1 griglia / grid 505 x 215 mm

**G-EF200G - G-EF200GSS**

2 ripiani fissi / fixed shelves  
480 x 440 mm

	G-ER200G	G-EF200G	G-ER200GSS	G-EF200GSS
	+2°C / +8°C	-18°C / -22°C	+2°C / +8°C	-18°C / -22°C
	600 x 585 x 855(h) mm			
	510 x 485 x 620(h) mm			
	130 L			
	+32°C / 55%HR			
	evaporatore a piastra / plate evaporator	evaporatore a ripiani / shelves evaporator	evaporatore a piastra / plate evaporator	evaporatore a ripiani / shelves evaporator
<b>DEFROST</b>	automatico automatic	manuale manual	automatico automatic	manuale manual
<b>GAS</b>	R600a	R290	R600a	R290
	automatica / automatic			
	termostato / thermostat			
	40 mm			
	105 W	270 W	105 W	270 W
	230V / 50Hz			
<b>MATERIAL</b>	lamiera verniciata / painted tin plate ABS + vetrocamera / insulating glass		acciaio Inox / stainless steel AISI 430 ABS - vetrocamera / insulating glass	
	si / yes	no	si / yes	no
	led			
<b>ENERGY CLASS</b>				
	44 Kg	45 Kg	44 Kg	45 Kg
	56 Kg	57 Kg	56 Kg	57 Kg
	680 x 650 x 1160(h) mm			

## Eco Line

Armadi refrigerati - statici / Refrigerated cabinets - static  
Armoires réfrigérées - statiques / Kühlschränke - statische Kühlung

# G-ER400G - G-EF400G G-ER400GSS - G-EF400GSS



G-ER400G

**B**

G-ER400GSS

NERO / BLACK  
pag. 207

## STANDARD

### G-ER400G - G-ER400GSS

3 griglie / grids 505 x 415 mm  
+ 1 griglia / grid 505 x 215 mm

### G-EF400G - G-EF400GSS

6 ripiani fissi / fixed shelves  
480 x 440 mm

	G-ER400G	G-EF400G	G-ER400GSS	G-EF400GSS
	+2°C / +8°C	-18°C / -22°C	+2°C / +8°C	-18°C / -22°C
	600 x 585 x 1855(h) mm			
	510 x 485 x 1620(h) mm			
	340 L			
	+32°C / 55%HR			
	evaporatore a piastra / plate evaporator	evaporatore a ripiani / shelves evaporator	evaporatore a piastra / plate evaporator	evaporatore a ripiani / shelves evaporator
DEFROST	automatico automatic	manuale manual	automatico automatic	manuale manual
GAS	R600a	R290	R600a	R290
	automatica automatic	manuale manual	automatica automatic	manuale manual
CONTROL	termostato / thermostat			
	45 mm	60 mm	45 mm	60 mm
	185 W	380 W	185 W	380 W
	230V / 50Hz			
MATERIAL	lamiera verniciata / painted tin plate ABS + vetrocamera / insulating glass		acciaio Inox / stainless steel AISI 430 ABS - vetrocamera / insulating glass	
REVERSIBLE	si / yes	no	si / yes	no
	led			
ENERGY CLASS	<b>B</b>	<b>C</b>	<b>B</b>	<b>C</b>
	69 Kg	76 Kg	69 Kg	76 Kg
	81 Kg	102 Kg	81 Kg	102 Kg
	680 x 650 x 2210(h) mm			

# G-ER600G - G-EF600G G-ER600GSS - G-EF600GSS



G-ER600G

G-ER600GSS

## STANDARD

### G-ER600G - G-ER600GSS

3 griglie / grids 650 x 520 mm  
+ 1 griglia / grid 650 x 290 mm

### G-EF600G - G-EF600GSS

6 ripiani fissi / fixed shelves  
650 x 510 mm

	G-ER600G	G-EF600G	G-ER600GSS	G-EF600GSS
	+2°C / +8°C	-18°C / -22°C	+2°C / +8°C	-18°C / -22°C
	777 x 695 x 1895(h) mm			
	657 x 580 x 1660(h) mm			
	570 L			
	+32°C / 55%HR			
	evaporatore a piastra / plate evaporator	evaporatore a ripiani / shelves evaporator	evaporatore a piastra / plate evaporator	evaporatore a ripiani / shelves evaporator
DEFROST	automatico automatic	manuale manual	automatico automatic	manuale manual
GAS	R600a	R290	R600a	R290
	automatica automatic	manuale manual	automatica automatic	manuale manual
CONTROL	termostato / thermostat			
	60 mm			
	185 W	480 W	185 W	480 W
	230V / 50Hz			
MATERIAL	lamiera verniciata / painted tin plate ABS + vetrocamera / insulating glass		acciaio Inox / stainless steel AISI 430 ABS - vetrocamera / insulating glass	
REVERSIBLE	si / yes	no	si / yes	no
	led			
ENERGY CLASS				
	93 Kg	94 Kg	93 Kg	94 Kg
	107 Kg	111 Kg	107 Kg	111 Kg
	840 x 760 x 2210(h) mm			

## Eco Line

Armadi refrigerati - statici / Refrigerated cabinets - static  
Armoires réfrigérées - statiques / Kühlschränke - statische Kühlung

# G-ER500P G-ER500PSS

Ideali per pasticceria / For pastry



G-ER500P

G-ER500PSS

	G-ER500P	G-ER500PSS
	+2°C / +8°C	
	780 x 715 x 1750(h) mm	
	667 x 570 x 1485(h) mm	
	520 L	
	+32°C / 55%HR	
	evaporatore a piastra / plate evaporator	
<b>DEFROST</b>	automatico / automatic	
<b>GAS</b>	R600a	
	automatica / automatic	
	termostato / thermostat	
	55 mm	
	150 W	
	230V / 50Hz	
<b>MATERIAL</b>	lamiera verniciata / painted tin plate - ABS	acciaio Inox / stainless steel AISI 430 - ABS
<b>REVERSIBLE</b>	si / yes	
	no	
<b>STANDARD</b>	6 coppie guide per teglie / pairs of slides for trays 600 x 400 mm	
<b>ENERGY CLASS</b>		
	90 Kg	
	107 Kg	
	840 x 760 x 2210(h) mm	



Eco Line

Armadi refrigerati - statici / Refrigerated cabinets - static  
Armoires réfrigérées - statiques / Kühlschränke - statische Kühlung

# Armadi refrigerati

## GN2/1 - statici - Eco Line

IT Armadi refrigerati con refrigerazione statica e misure GN2/1. Struttura in lamiera verniciata epossidica bianca, interno in alluminio - refrigerazione statica con ventilatore e convogliatore d'aria interno per uniformare la temperatura - gruppo incorporato in vano superiore - vano motore con fianchi coibentati - controllo temperatura elettronico con termostato digitale - resistenza elettrica intorno alla cornice porta per eliminazione della condensa. Eliminazione dell'acqua di condensa tramite bacinella. Porta con molla di ritorno - chiusura porta con chiave - guarnizione porta estraibile senza utensili - fondo con angoli arrotondati - pannelli esterni di fondo e schienale in lamiera galvanizzata. Piedini in acciaio Inox AISI 304 regolabili in altezza.

EN Refrigerated cabinets with static refrigeration and GN2/1 size. Casing in white epoxy painted plate, inside in aluminium - static refrigeration with fan and internal air conveyor to even out the temperature - incorporated refrigerating unit in the upper compartment - motor compartment with insulated sides - electronic temperature control with digital thermostat - electrical heating element around the door frame to eliminate condensation. Drip tray to collect condensation water. Door with self-closing spring - door lock with key - tool-free extractable door gasket - bottom with rounded corners - external back and bottom panels in galvanised plate. Height-adjustable feet in stainless steel AISI 304.

FR Armoires réfrigérées GN2/1 avec réfrigération statique. Corps extérieur en tôle peinte en blanc époxy, structure intérieure en aluminium - réfrigération statique avec ventilateur et convoyeur d'air interne pour uniformiser la température - groupe incorporé dans le compartiment supérieur - compartiment moteur avec côtés isolés - régulation électronique de la température avec thermostat digital - résistance électrique autour du cadre de porte pour éliminer la condensation - élimination de l'eau de condensation avec bac. Porte avec ressort auto-fermant - fermeture de la porte par clé - joint de porte extractible sans outils - fond avec coins arrondis - panneaux de fond extérieurs et panneau postérieur en tôle galvanisée - pieds en acier inox AISI 304 réglables en hauteur.

DE GN2/1 Kühlschränke mit statischer Kühlung - Äußere Gehäuse aus weißem, epoxidlackiertem Blech, Innengehäuse aus Aluminium - statische Kühlung - Gebläse und interner Luftförderer zur Temperaturregelung - integrierte Einheit im oberen Raum - Motorraum mit isolierten Seiten - elektronische Temperaturregelung mit digitalem Thermostat - elektrischer Heizstab um den Türrahmen herum zur Vermeidung von Kondensation - Beseitigung von Kondenswasser durch eine Wanne. Tür mit Rückholfeder - Türschließung mit Schlüssel - Türdichtung werkzeuglos abnehmbar - Boden mit abgerundeten Ecken - äußere Rücken- und Bodenverkleidung aus verzinktem Blech - Höhenverstellbare Füße aus Edelstahl AISI 304.

## OPTIONAL

CG21	GRP21	P60	RUO120
		G-GNB600TN-BT G-GNB1200TN-BT	
	GN2/1 640 x 530 mm	600 x 400 mm	ø 120 mm
Coppia guide per griglia Pair of slides for grid Paire de glissières pour grille Führungsschienenpaar für Gitterrost	Griglia plastificata Plastic coated grid Grille plastifiée Kunststoffgitter	Kit supporti e 9 coppie di guide per teglie Set of supports and 9 pairs of runners for pans Kit de supports et 9 paires de glissières pour bacs Trägersatz und 9 Paare Führungsschienen für Bleche	Kit 4 ruote di cui 2 con freno Set of 4 wheels, 2 with brake Jeu de 4 roues, 2 avec frein Satz mit 4 Rädern, 2 mit Bremse

# G-GNB600TN G-GNB600BT



	G-GNB600TN	G-GNB600BT
	+2°C / +8°C	-18°C / -20°C
	680 x 800 x 2010(h) mm	
	560 x 653 x 1386(h) mm	
	507 L	
	+32°C / 55%HR	
	statica / static	
<b>DEFROST</b>	automatico / automatic	manuale / manual
<b>GAS</b>	R290	
	vasca di raccolta / collecting basin	
	elettronico / electronic	
<b>CONTROL</b>	60 mm	
	260 W	510 W
	230V / 50Hz	
<b>MATERIAL</b>	lamiera verniciata / painted tin plate - alluminio / aluminium	
	si / yes	
	no	
<b>STANDARD</b>	3 griglie / grids GN2/1 + 3 coppie di guide / pairs of slides	
<b>ENERGY CLASS</b>		
	135 Kg	
	155 Kg	
	710 x 840 x 2180(h) mm	

# G-GNB1200TN G-GNB1200BT

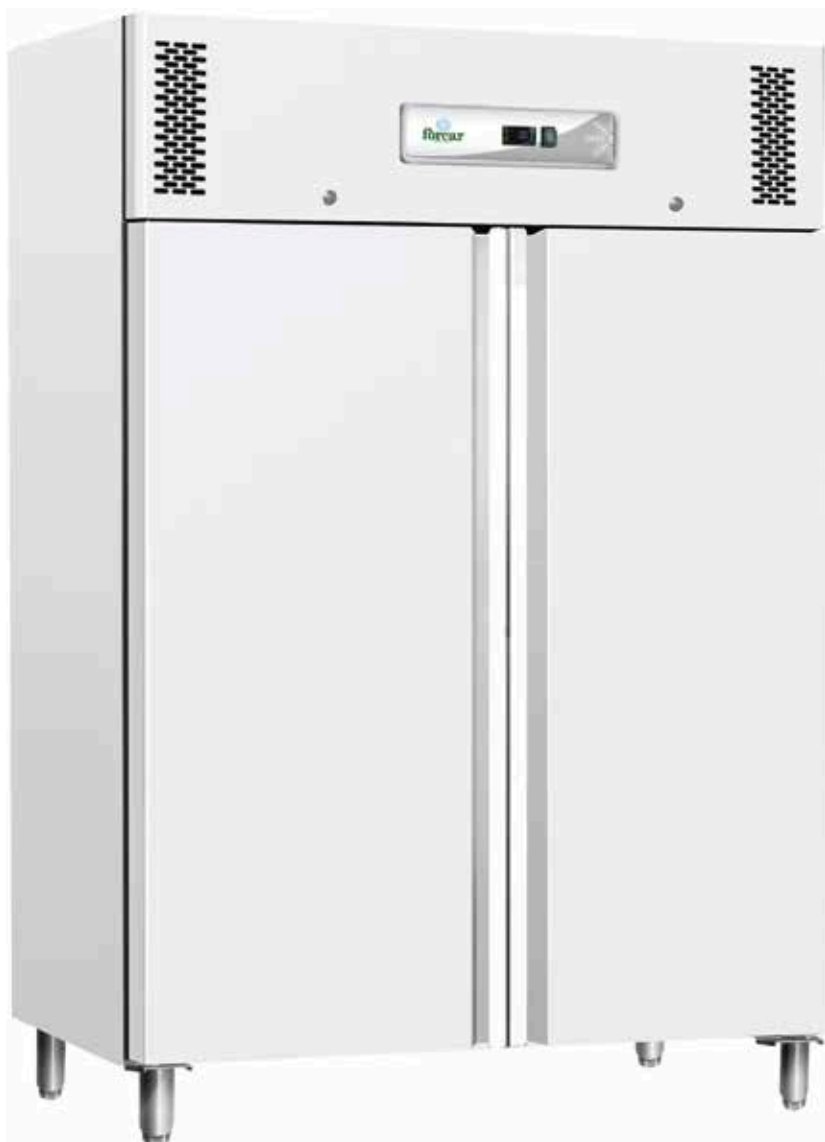

	G-GNB1200TN	G-GNB1200BT
	+2°C / +8°C	-18°C / -20°C
	1340 x 800 x 2010(h) mm	
	1220 x 653 x 1386(h) mm	
	1104 L	
	+32°C / 55%HR	
	statica / static	
<b>DEFROST</b>	automatico / automatic	manuale / manual
<b>GAS</b>	R290	
	vasca di raccolta / collecting basin	
	elettronico / electronic	
<b>CONTROL</b>	60 mm	
	450 W	710 W
	230V / 50Hz	
<b>MATERIAL</b>	lamiera verniciata / painted tin plate - alluminio / aluminium	
	no	
	no	
<b>STANDARD</b>	6 griglie / grids GN2/1 6 coppie di guide / pairs of slides	
<b>ENERGY CLASS</b>		
	180 Kg	
	204 Kg	
	1370 x 840 x 2180(h) mm	



## Eco Line

Armadi refrigerati - GN2/1 - statici / Refrigerated cabinets - static - GN2/1  
Armoires réfrigérées - statiques - GN2/1 / Kühlschränke - statische Kühlung - GN2/1

# Congelatori a pozzetto statici - Eco Line

IT Congelatori a pozzetto con refrigerazione statica. Struttura esterna in acciaio verniciato bianco - interna in alluminio goffrato. Controllo temperatura manuale con termostato manuale - eliminazione dell'acqua di condensa tramite tubo di scarico - sbrinamento manuale.

EN Deep-freezers with static refrigeration. External casing in white painted steel - casted aluminium inside. Manual temperature control with manual thermostat - condensation water drain through a pipe - manual defrosting.

FR Congélateurs coffres avec réfrigération statique. Corps extérieur en acier laqué blanc - corps intérieur en aluminium gaufré. Régulation manuelle de la température avec thermostat manuel - élimination de l'eau de condensation au moyen d'un tuyau d'évacuation - dégivrage manuel.

DE Gefriertruhen mit statischer Kühlung. Außengehäuse aus weißlackiertem Stahl - Innengehäuse aus geprägtem Aluminium. Manuelle Temperaturregelung mit manuellem Thermostat - Kondenswasserentleerung über eine Ablassleitung - manuelle Abtauung.

## OPTIONAL

CEP01	CEP02	CEP03	CEP04
G-SD100S - G-SD200S	G-SD320PS	G-BD350S - G-BD450S G-BD550S - G-BD650S	G-BD205S - G-BD305S
Cestello per congelatore a pozzetto - Basket for deepfreezer - Panier pour congélateur coffre - Korb für Tiefkühltruhe			
			

# G-BD205S G-BD305S G-BD350S



G-BD205S

- Porta a ribalta / Flap door
- 1 cestello compreso / 1 basket included



G-BD305S



## Eco Line

Armadi refrigerati - GN2/1 - statici / Refrigerated cabinets - static - GN2/1  
Armoires réfrigérées - statiques - GN2/1 / Kühlschränke - statische Kühlung - GN2/1

	G-BD205S	G-BD305S	G-BD350S
	≤ -18		
	960 x 525 x 840(h) mm	1160 x 525 x 850(h) mm	1035 x 680 x 850(h) mm
	810 x 374 x 645(h) mm	1015 x 375 x 665(h) mm	875 x 520 x 660(h) mm
	190 L	242 L	269 L
	+38°C / 60%HR		
	statica / static		
<b>DEFROST</b>	manuale / manual		
<b>GAS</b>	R600a		
	con tubo di scarico / with drain pipe		
	meccanico / mechanical		
	64 mm		70 mm
	56 W	61 W	64 W
	230V / 50Hz		
<b>MATERIAL</b>	lamiera verniciata bianca + alluminio goffrato white painted metal sheet + embossed aluminium		
	no		
<b>STANDARD</b>	paletta di sbrinamento / defrost shovel		
<b>ENERGY CLASS</b>			
	39 Kg	46 Kg	52 Kg
	43 Kg	50,5 Kg	57,5 Kg
	1005 x 585 x 905(h) mm	1210 x 585 x 905(h) mm	1080 x 780 x 905(h) mm

# G-BD450S G-BD550S G-BD650S



G-BD450S / G-BD550S

- Porta a ribalta / Flap door
- 1 cestello compreso / 1 basket included



G-BD650S

	G-BD450S	G-BD550S	G-BD650S
	≤ -18		
	1276 x 680 x 850(h) mm	1535 x 680 x 840(h) mm	1810 x 680 x 860(h) mm
	1115 x 520 x 660(h) mm	1370 x 525 x 645(h) mm	1650 x 520 x 660(h) mm
	354 L	439 L	537 L
	+38°C / 60%HR		
	statica / static		
<b>DEFROST</b>	manuale / manual		
<b>GAS</b>	R600a		
	con tubo di scarico / with drain pipe		
	meccanico / mechanical		
	70 mm		
	69 W	71 W	98 W
	230V / 50Hz		
<b>MATERIAL</b>	lamiera verniciata bianca + alluminio goffrato white painted metal sheet + embossed aluminium		
	no		
<b>STANDARD</b>	paletta di sbrinamento / defrost shovel		
<b>ENERGY CLASS</b>			
	59 Kg	68,5 Kg	76 Kg
	65,5 Kg	75 Kg	83,5 Kg
	1400 x 780 x 1000(h) mm	1580 x 780 x 1040(h) mm	1870 x 770 x 1110(h) mm

# G-SD100S G-SD200S G-SD320PS



G-SD100S

- Apertura superiore scorrevole / Upper sliding lid
- 1 cestello compreso / 1 basket included



G-SD200S / G-SD320PS



## Eco Line

Congelatori a pozzetto / Deep freezers  
Congélateurs Coffres / Gefriertruhen

	G-SD100S	G-SD200S	G-SD320PS
	≤ -18		
	580 x 520 x 810(h) mm	960 x 520 x 810(h) mm	1030 x 675 x 840(h) mm
	430 x 370 x 680(h) mm	810 x 370 x 680(h) mm	880 x 520 x 630(h) mm
	97 L	197 L	245 L
	+43°C / 60%HR		
	statica / static		
<b>DEFROST</b>	manuale / manual		
<b>GAS</b>	R600a	R290	
	con tubo di scarico / with drain pipe		
	meccanico / mechanical		
	64 mm		70 mm
	58 W	110 W	198 W
	230V / 50Hz		
<b>MATERIAL</b>	lamiera verniciata bianca + alluminio goffrato white painted metal sheet + embossed aluminium		
	no		
<b>STANDARD</b>	paletta di sbrinamento / defrost shovel		
<b>ENERGY CLASS</b>			
	28 Kg	43,5 Kg	56,5 Kg
	30,5 Kg	47 Kg	61,5 Kg
	630 x 580 x 1060(h) mm	1010 x 580 x 1090(h) mm	1080 x 780 x 890(h) mm



# Glass Line

# Vetrine espositive 4 lati

## ventilate - statiche - Glass Line

IT Vetrine espositive con refrigerazione ventilata o statica. Quattro lati espositivi con vetrocamera - panoramica di tutti i prodotti - efficienza termica - sbrinamento automatico (tranne per il modello G-VGP420BT che avviene tramite vaschetta) - controllo temperatura elettronico - luce interna a LED.

EN Display windows with ventilated or static refrigeration. Four display sides with double-glazing - overview of all products - thermal efficiency - automatic defrosting (except for the G-VGP420BT model, which uses a tray) - electronic temperature control - internal LED light.

FR Vitrines avec réfrigération ventilée ou statique. Quatre faces d'exposition avec double vitrage - vue d'ensemble de tous les produits - efficacité thermique - dégivrage automatique (sauf pour le modèle G-VGP420BT, qui utilise un récipient de collecte) - contrôle électronique de la température - éclairage interne par LED.

DE Aufsatzvitrinen mit Umluft- oder statischer Kühlung. Vier Ausstellungsseiten mit Doppelverglasung - Übersicht über alle Produkte - thermische Leistungsfähigkeit - automatische Abtauung (mit Ausnahme des Modells G-VGP420BT, welches über eine Auffangwanne verfügt) - elektronische Temperaturkontrolle - interne LED-Beleuchtung.

## OPTIONAL

GRCVGP420	GRCVGP	GRP65B	GRCLSCB ●	GRCLSC ●	GRPTCDBD ●	GRPTCBD ●
G-VGP420	G-VGP200R - VGP400R	G-LSC65B - LSC65LB LDC65B - LDC65LB	G-LSC235B LSC280B	G-LSC235 LSC280	G-TCBD68B TCBD98B	G-TCBD68 TCBD98
530 x 450 mm	510 x 485 mm	530 x 417 mm	404 x 411 mm		375 x 335 mm	
Griglia cromata - Chromed grids Grille chromée - Verchromter Gitterrost		Ripiano in vetro - Glass Shelf Étagères en verre - Glasböden	Griglia plastificata - Plastic coated grid Grille plastifiée - Kunststoffgitter			

AG	AG1	AGTCBD
G-VGP200 - VGP400R LSC235 - LSC280	G-LDC65B - G-LDC65LB G-LSC65B - G-LSC65LB	G-TCBD68 - TCBD98
Set aggancio per griglie - Clamping set for grids Jeu de serrage pour grilles - Klemmset für Gitterroste		Coppia aggancio per griglie - Pair of hooks for grilles Paire accrochage pour grilles - Ankupplungspaar für Abstellgitter



















# G-VGP420TN G-VGP420BT



  
MADE IN ITALY

G-VGP420BT

G-VGP420TN

	G-VGP420TN	G-VGP420BT
		
	-2°C / +15°C	-15°C / -24°C
	700 x 650 x 1900(h) mm	
	420 L	
	+30°C / 60%HR	
	ventilata / ventilated	statica / static
<b>DEFROST</b>	automatico / automatic	manuale / manual
<b>GAS</b>	R290	
	automatica / automatic	vasca di raccolta / collecting basin
	elettronico / electronic	
	triplo vetro / triple glazing	
	550 W	650 W
	230V / 50Hz	
<b>MATERIAL</b>	alluminio anodizzato / aluminium	
	no	
	led	
<b>STANDARD</b>	5 ripiani regolabili in altezza / adjustable shelves 530 x 450 mm	5 ripiani fissi / fixed shelves 520 x 440 mm + 1 griglia / grid 530 x 450 mm
<b>ENERGY CLASS</b>		
		
	172 Kg	177 Kg
	192 Kg	197 Kg
	760 x 730 x 2150(h) mm	

# G-VGP200R G-VGP400R



G-VGP200R

G-VGP400R



## Glass Line

Vetrine 4 lati espositivi refrigerate / 4-sides refrigerated display windows  
Vitrines réfrigérées 4 faces / Kühlvitrine mit 4 Ausstellungsseiten

	G-VGP200R	G-VGP400R
	+2°C / +8°C	
	701x 742 x 1300(h) mm	706 x 740 x 1800(h) mm
	638 x 628 x 618(h) mm	638 x 628 x 1180(h) mm
	200 L	408 L
	+32°C / 55%HR	
	ventilata / ventilated	
<b>DEFROST</b>	automatico / automatic	
<b>GAS</b>	R290	
	automatica / automatic	
	elettronico / electronic	
<b>CONTROL</b>	doppio vetro / double glazing	
	260 W	330 W
	230V / 50Hz	
<b>1 Ph</b>		
<b>MATERIAL</b>	acciaio inox / stainless steel AISI 430 + vetro / glass	
	no	
	led	
<b>STANDARD</b>	2 griglie / grids 510 x 485 mm	4 griglie / grids 510 x 485 mm
<b>ENERGY CLASS</b>		
	96 Kg	180 Kg
	116 Kg	210 Kg
	760 x 820 x 1540(h) mm	760 x 820 x 2040(h) mm

# G-LDC65B G-LDC65LB



G-LDC65LB

G-LDC65B

	G-LDC65B	G-LDC65LB
	-18°C / -22°C	
	650 x 650 x 1500(h) mm	650 x 650 x 1950(h) mm
	588 x 515 x 925(h) mm	588 x 515 x 1425(h) mm
	280 L	431 L
	+32°C / 80%HR	
	ventilata / ventilated	
<b>DEFROST</b>	automatico / automatic	
<b>GAS</b>	R290	
	automatica / automatic	
	elettronico / electronic	
<b>CONTROL</b>	1000 W	
	230V / 50Hz	
	1 Ph	
<b>MATERIAL</b>	lamiera verniciata / painted tin plate + plastica / plastic + vetro / glass	
	no	
	led	
<b>STANDARD</b>	3 ripiani in vetro glass shelf 530 x 417 mm	5 ripiani in vetro glass shelf 530 x 417 mm
<b>ENERGY CLASS</b>		
	130 Kg	203 Kg
	160 Kg	230 Kg
	720 x 720 x 1720(h) mm	720 x 720 x 2170(h) mm

# G-LSC65B G-LSC65LB



G-LSC65LB

G-LSC65B

	G-LSC65B	G-LSC65LB
	+2°C / +8°C	
	650 x 650 x 1500(h) mm	650 x 650 x 1950(h) mm
	588 x 515 x 925(h) mm	588 x 515 x 1425(h) mm
	280 L	431 L
	+32°C / 80%HR	
	ventilata / ventilated	
<b>DEFROST</b>	automatico / automatic	
<b>GAS</b>	R290	
	automatica / automatic	
	elettronico / electronic	
	320 W	
	230V / 50Hz	
<b>MATERIAL</b>	lamiera verniciata / painted tin plate + plastica / plastic + vetro / glass	
	no	
	led	
<b>STANDARD</b>	3 ripiani in vetro glass shelf 530 x 417 mm	5 ripiani in vetro glass shelf 530 x 417 mm
<b>ENERGY CLASS</b>		
	130 Kg	203 Kg
	160 Kg	230 Kg
	720 x 720 x 1720(h) mm	720 x 720 x 2170(h) mm



## Glass Line

Vetrine 4 lati espositivi refrigerate - ventilate / 4-sides refrigerated display windows - ventilated  
Vitrines réfrigérées 4 faces - ventilées / Kühlvitrine mit 4 Ausstellungsseiten - Umluftgekühlt

# G-LSC235 G-LSC280



G-LSC235



G-LSC280

	G-LSC235	G-LSC280
	+2°C / +8°C	
	515 x 485 x 1695(h) mm	515 x 485 x 2035(h) mm
	473 x 408 x 1138(h) mm	473 x 408 x 1338(h) mm
	235 L	280 L
	+32°C / 60%HR	
	ventilata / ventilated	
<b>DEFROST</b>	automatico / automatic	
<b>GAS</b>	R290	
	automatica / automatic	
	elettronico / electronic	
	doppio vetro / double glazing	
	260 W	
	230V / 50Hz	
<b>MATERIAL</b>	lamiera verniciata / painted tin plate + plastica / plastic + vetro / glass	
	no	
	led	
<b>STANDARD</b>	3 griglie / grids 404 x 411 mm	4 griglie / grids 404 x 411 mm
<b>ENERGY CLASS</b>		
<b>NET Kg</b>	96 Kg	107 Kg
<b>GROSS Kg</b>	110 Kg	127 Kg
	575 x 545 x 1885(h) mm	575 x 545 x 2085(h) mm

# G-LSC235B G-LSC280B



G-LSC235B



G-LSC280B

	G-LSC235B	G-LSC280B
	+2°C / +8°C	
	515 x 485 x 1695(h) mm	515 x 485 x 2035(h) mm
	473 x 408 x 1138(h) mm	473 x 408 x 1338(h) mm
	235 L	280 L
	+32°C / 60%HR	
	ventilata / ventilated	
<b>DEFROST</b>	automatico / automatic	
<b>GAS</b>	R290	
	automatica / automatic	
	elettronico / electronic	
<b>CONTROL</b>	doppio vetro / double glazing	
	260 W	
	230V / 50Hz	
	1 Ph	
<b>MATERIAL</b>	lamiera verniciata / painted tin plate + plastica / plastic + vetro / glass	
	no	
	led	
<b>STANDARD</b>	3 griglie / grids 404 x 411 mm	4 griglie / grids 404 x 411 mm
<b>ENERGY CLASS</b>		
	96 Kg	107 Kg
	110 Kg	127 Kg
	575 x 545 x 1885(h) mm	575 x 545 x 2085(h) mm



## Glass Line

Vetrine 4 lati espositivi refrigerate - ventilate / 4-sides refrigerated display windows - ventilated  
Vitrines réfrigérées 4 faces - ventilées / Kühlvitrine mit 4 Ausstellungsseiten - Umluftgekühlt

# G-TCBD68 G-TCBD98



G-TCBD68

G-TCBD98

	G-TCBD68	G-TCBD98
	+2°C / +8°C	
	428 x 386 x 924(h) mm	428 x 386 x 1150(h) mm
	400 x 358 x 535(h) mm	400 x 358 x 760(h) mm
	68 L	98 L
	+32°C / 60%HR	
	ventilata / ventilated	
<b>DEFROST</b>	automatico / automatic	
<b>GAS</b>	R600a	
	automatica / automatic	
	elettronico / electronic	
<b>CONTROL</b>	doppio vetro / double glazing	
	160 W	170 W
	230V / 50Hz	
	1 Ph	
<b>MATERIAL</b>	lamiera verniciata bianca + plastica + vetro white painted tin plate + plastic + glass	
	no	
	led	
<b>STANDARD</b>	3 griglie / grids 375 x 335 mm	4 griglie / grids 375 x 335 mm
<b>ENERGY CLASS</b>		
	33 Kg	38 Kg
	35 Kg	48 Kg
	495 x 460 x 975(h) mm	495 x 460 x 1310(h) mm

# G-TCBD68B G-TCBD98B



G-TCBD68B

G-TCBD98B

	G-TCBD68B	G-TCBD98B
	+2°C / +8°C	
	428 x 386 x 924(h) mm	428 x 386 x 1150(h) mm
	400 x 358 x 535(h) mm	400 x 358 x 760(h) mm
	68 L	98 L
	+32°C / 60%HR	
	ventilata / ventilated	
<b>DEFROST</b>	automatico / automatic	
<b>GAS</b>	R600a	
	automatica / automatic	
	elettronico / electronic	
	doppio vetro / double glazing	
	160 W	170 W
	230V / 50Hz	
	1 Ph	
<b>MATERIAL</b>	lamiera verniciata nera + plastica + vetro black painted tin plate + plastic + glass	
	no	
	led	
<b>STANDARD</b>	3 griglie / grids 375 x 335 mm	4 griglie / grids 375 x 335 mm
<b>ENERGY CLASS</b>		
	33 Kg	38 Kg
	35 Kg	41 Kg
	495 x 460 x 975(h) mm	495 x 460 x 1200(h) mm



## Glass Line

Vetrine 4 lati espositivi refrigerate - ventilate / 4-sides refrigerated display windows - ventilated  
Vitrines réfrigérées 4 faces - ventilées / Kühlvitrine mit 4 Ausstellungsseiten - Umluftgekühlt

# Vetrinette espositiva

## refrigerate - ventilate - Glass Line

IT Vetrinette espositive con refrigerazione ventilata. Quattro lati espositivi - panoramica di tutti i prodotti esposti - efficienza termica data dal vetro-camera - sbrinamento temporizzato con vaschetta di raccolta condensa auto-evaporante - ante scorrevoli su entrambi i lati - illuminazione a LED.

EN Display windows with ventilated refrigeration. Four display sides - overview of all displayed products - thermal efficiency given by the double glazing - time-controlled defrosting with self-evaporating condensate collection tray - sliding doors on both sides - LED lighting.

FR Vitrines avec réfrigération ventilée. Quatre faces vitrées avec isolation thermique - vue d'ensemble de tous les produits - efficacité thermique donnée par le double vitrage - dégivrage temporisé avec bac de récupération de condensat auto-extractible - portes vitrées coulissantes des deux côtés - éclairage interne par LED.

DE Aufsatzvitrinen mit Umluftkühlung. Vier Ausstellungsseiten - Übersicht über alle Produkte - thermische Leistungsfähigkeit dank der Doppelverglasung - zeitgesteuerte Abtauung mit automatischer Verdampfung des Kondenswasser in der Abtropfschale - Schiebeglas auf beiden Seiten - LED-Innenbeleuchtung.

### OPTIONAL

GRC91	GRC111	GRC131	AG
G-HAV91	G-HAV111	G-HAV131	G-HAV91-HAV111-HAV131
Griglia cromata - Chromed grids - Grilles chromes - Verchromte Gitter			Set aggancio per griglie - Clamping set for grids Jeu de serrage pour grilles - Klemmset für Gitterroste

## G-HAV91



## G-HAV111



- Porta scorrevole  
Doppia apertura  
- Sliding doors  
on both sides

## G-HAV131



	G-HAV91	G-HAV111	G-HAV131
	+2°C / +8°C		
	910 x 510 x 550(h) mm	1110 x 510 x 550(h) mm	1310 x 510 x 550(h) mm
	565 x 420 x 460(h) mm	760 x 420 x 460(h) mm	965 x 420 x 460(h) mm
	110 L	150 L	190 L
	+28°C / 60%HR		
	ventilata / ventilated		
DEFROST	automatico / automatic		manuale / manual
GAS	R600a		
	automatica / automatic		manuale / manual
	elettronico / electronic	termostato / thermostat	
CONTROL	doppio vetro / double glazing		
	180 W		
	230V / 50Hz		
MATERIAL	acciaio inox / stainless steel AISI 430 + plastica / plastic + vetro / glass		
	led		
STANDARD	1 griglia / grid 390 x 552 mm	1 griglia / grid 390 x 752 mm	1 griglia / grid 390x 952 mm
ENERGY CLASS			
	59 Kg	70 Kg	72 Kg
	70 Kg	81 Kg	84 Kg
	970 x 570 x 750(h) mm	1170 x 570 x 750(h) mm	1370 x 570 x 750(h) mm

## Glass Line

Vetrinette espositive refrigerate / Refrigerated display windows  
Vitrines réfrigérées / Aufsatzkühlvitrinen

# Espositori murali refrigerati - ventilati - Glass Line

IT Espositori murali refrigerati con refrigerazione ventilata. Sbrinamento automatico - luce interna a led - controllo temperatura digitale con display - base in acciaio inox - vetri laterali e tendina frontale scorrevole - ripiani in acciaio inox 4 ruote di cui 2 con freno.

EN Refrigerated wall displays cases with ventilated refrigeration. Automatic defrosting - internal led light - digital temperature control with display - stainless steel base - sliding side glass panels and sunshade - stainless steel shelves, 4 wheels, 2 of which with brake.

FR Présentoirs réfrigérés à mur avec réfrigération ventilée. Dégivrage automatique - éclairage interne à LED - thermorégulation numérique avec afficheur - piètement en acier inox - vitres latérales et rideau avant coulissant - étagères en acier inox 4 roues dont 2 avec frein.

DE Wandkühlvittrinen mit Umluftkühlung. Automatische Abtauung - LED-Innenbeleuchtung - digitale Temperaturregelung mit Display - Edelstahlunterteil - seitliche Schaugläser und Schiebevorhang - Edelstahlzwischenregale, 4 Räder, 2 davon mit Bremse.



RTS200C

# RTS200C RTS180C



RTS180C

- Vetri laterali e tendina frontale
- Sliding side glass panels and sunshade

	RTS200C	RTS180C
	+2°C / +10°C	
	1000 x 638 x 1250(h) mm	494 x 674 x 1450(h) mm
	200 L	180 L
	+28°C / 60%HR	
	ventilata / ventilated	
<b>DEFROST</b>	automatico / automatic	
<b>GAS</b>	R290	
	automatica / automatic	
	elettronico / electronic	termostato / thermostat
	1300 W	
	230V / 50Hz	
<b>MATERIAL</b>	acciaio inox / stainless steel AISI 430 + vetro / glass	
	tendina / curtain only	
	led	
<b>STANDARD</b>	2 ripiani in acciaio inox AISI 430 2 shelves stainless steel AISI 430	
<b>ENERGY CLASS</b>	<b>E</b>	<b>G</b>
	115 Kg	82 Kg
	121 Kg	91 Kg
	1080 x 640 x 1430(h) mm	720 x 570 x 1760(h) mm



## Glass Line

Espositori murali refrigerati - ventilati / Refrigerated wall displays cases - ventilated  
Présentoirs réfrigérés à mur - ventilées / Wandkühlvitrinen - Umluftgekühlt

# Espositori refrigerati con vetro tondo - ventilati - Glass Line

- IT Espositori refrigerati con vetro tondo e refrigerazione ventilata. Parte espositiva tutta in vetro - panoramica di tutto il prodotto - efficienza termica. Sbrinatorio automatico - controllo temperatura elettronico - luce interna a LED. Mod. ARC100B da banco con 4 piedini. Mod. ARC400RC con 5 ruote di cui 2 con freno.
- FR Présentoirs réfrigérés avec verre rond et réfrigération ventilée. Surface d'exposition entièrement en verre - vue d'ensemble du produit entier - efficacité thermique. Dégivrage automatique - contrôle électronique de la température - éclairage interne à LED. Mod. de table ARC100B avec 4 pieds. Mod. ARC400RC avec 5 roues, dont 2 avec frein.
- EN Refrigerated display cases with rounded glass and ventilated refrigeration. The whole display area is made of glass - full view of the product - thermal efficiency. Automatic defrosting - electronic temperature control - internal LED light. Counter-top Mod. ARC100B with 4 feet. Mod. ARC400RC with 5 wheels, 2 of which with brake.
- DE Kühlvitrinen mit Rundglas und Kühlung. Ausstellungsfläche ganz aus Glas - Überblick über das gesamte Produkt - thermische Effizienz. Automatische Abtauung - elektronische Temperaturregelung - LED Innenbeleuchtung. Tisch-Mod. ARC100B mit 4 Füßen. Mod. ARC400RC mit 5 Rädern, 2 davon mit Bremse.



# ARC100B ARC400RC



ARC100B



ARC400RC

	ARC100B	ARC400RC
	+2°C / +8°C	
	ø 480 x 1030(h) mm	ø 680 x 1750(h) mm
	ø 350 x 535(h) mm	ø 350 x 760(h) mm
	100 L	400 L
	+30°C / 55%HR	
	ventilata / ventilated	
<b>DEFROST</b>	automatico / automatic	
<b>GAS</b>	R290	
	automatica / automatic	
	elettronico / electronic	termostato / thermostat
	30 mm	
	210 W	
	230V / 50Hz	
<b>MATERIAL</b>	acciaio inox / stainless steel AISI 430 + vetro / glass	
<b>REVERSIBLE</b>	no	
	led	
<b>STANDARD</b>	3 ripiani in vetro glasses shelves	4 ripiani in vetro glasses shelves
<b>ENERGY CLASS</b>		
	50 Kg	127 Kg
	62 Kg	152 Kg
	570 x 570 x 1340(h) mm	800 x 755 x 2010(h) mm



## Glass Line

Espositori refrigerati con vetro tondo / Refrigerated display cases with rounded glass  
Présentoirs réfrigérés avec verre rond / Kühlvitrienen mit rundem Glas

# Espositori refrigerati ventilati - Glass Line

- IT Espositori refrigerati da banco con refrigerazione ventilata. Quattro lati espositivi - panoramica di tutti i prodotti - efficienza termica data dal vetro camera - sbrinamento automatico - controllo temperatura elettronico - struttura in vetro, materiale plastico e frontale inox - porte scorrevoli e luce interna a LED.
- EN Counter-top refrigerated display cases and ventilated refrigeration. Four display sides - overview of all products - thermal efficiency given by the double glazing - automatic defrosting - electronic temperature control - glass and plastic casing and stainless steel front - sliding doors and internal led light.
- FR Présentoirs de table réfrigérés et réfrigération ventilée. Quatre faces vitrées - vue d'ensemble de tous les produits - efficacité thermique donnée par le double vitrage - dégivrage automatique - contrôle électronique de la température - corps en verre, matière plastique et façade en acier inox - portes vitrées coulissantes et éclairage interne par LED.
- DE Kühlvitrinen und Umluftkühlung, Tischmodell. Vier Ausstellungsseiten - Übersicht über alle Produkte - thermische Leistungsfähigkeit dank der Doppelverglasung - automatische Abtauung - elektronische Temperaturregelung - Glas - und Kunststoffgehäuse und Edelstahlfrontblende - Schiebeglas und LED - Innenbeleuchtung.

# G-HTR125F G-HTR165F

New



G-HTR125F

DISPONIBILE DA  
AVAILABLE FROM 01/2026



## Glass Line

Espositori refrigerati - ventilati / Refrigerated display cases - ventilated  
Présentoirs réfrigérés - ventilées / Kühlvittrinen - Umluftgekühlt

	G-HTR125F	G-HTR165F
	+3°C / +8°C	
	695 x 576 x 680(h) mm	876 x 576 x 680(h) mm
	674 x 500 x 409(h) mm	852 x 500 x 409(h) mm
	137 L	174 L
	+28°C / 60%HR	
	ventilata / ventilated	
<b>DEFROST</b>	automatico / automatic	
<b>GAS</b>	R600a	
	automatica / automatic	
	elettronico / electronic	
	doppio vetro / double glazing	
	160 W	
	230V / 50Hz	
<b>MATERIAL</b>	acciaio inox / stainless steel AISI 430 + vetro / glass	
	no	
	led	
<b>STANDARD</b>	2 griglie / grids 642 x 376 / 642 x 412 mm	2 griglie / grids 820 x 376 / 820 x 412 mm
<b>ENERGY CLASS</b>		
	70 Kg	75 Kg
	87 Kg	97,5 Kg
	820 x 655 x 780(h) mm	995 x 655 x 780(h) mm

G-VPR100  
G-VPR120  
G-VPR160



G-VPR100

	G-VPR100	G-VPR120	G-VPR160
	+2°C / +8°C		
	695 x 462 x 670(h) mm	695 x 580 x 670(h) mm	873 x 580 x 670(h) mm
	663 x 380 x 384(h) mm	663 x 498 x 384(h) mm	841 x 498 x 384(h) mm
	100 L	120 L	160 L
	+28°C / 60%HR		
	ventilata / ventilated		
<b>DEFROST</b>	automatico / automatic	manuale / manual	
<b>GAS</b>	R600a		
	automatica / automatic	manuale / manual	
	elettronico / electronic	termostato / thermostat	
	doppio vetro / double glazing		
	150 W	160 W	
	230V / 50Hz 1 Ph		
<b>MATERIAL</b>	acciaio inox / stainless steel AISI 430 + vetro / glass		
	no		
	led		
<b>STANDARD</b>	2 griglie / grids 642x276 / 642x312 mm	2 griglie / grids 642x376 / 642x412 mm	2 griglie / grids 820x376 / 820x412 mm
<b>ENERGY CLASS</b>			
	57 Kg	70 Kg	75 Kg
	81 Kg	95 Kg	98 Kg
	810 x 532 x 860(h) mm	810 x 650 x 860(h) mm	990 x 650 x 850(h) mm



## Glass Line

Espositori refrigerati - ventilati / Refrigerated display cases - ventilated  
Présentoirs réfrigérés - ventilées / Kühlvitrinen - Umluftgekühlt

# Espositori in legno

## refrigerati - statici - Glass Line

IT Espositori con refrigerazione statica con struttura esterna in legno, disponibili con interno bianco o nero ed esternamente in diversi colori come noce chiaro, noce scuro e carbon. Porte con telaio in legno massiccio e vetrocamera - refrigerazione di tipo statico con evaporatore in piastra di alluminio posizionato sulla parete di fondo - termoregolatore per il controllo automatico della temperatura - evaporazione acqua di condensa automatica - illuminazione a LED comandata da interruttore - ventilatore interno collegato direttamente all'alimentazione per rendere uniforme la temperatura.

EN Displays with static refrigeration with an external wooden casing, available with a white or black interior and externally in different colours such as light walnut, dark walnut and carbon. Doors with solid wood frame and double-glazing - static refrigeration with aluminium plate evaporator positioned on the back - temperature regulator for automatic temperature control - automatic condensation water evaporation - LED lighting controlled by a switch - internal fan connected directly to the power supply to make the temperature uniform.

FR Présentoirs avec réfrigération statique avec corps extérieur en bois, disponibles avec un intérieur blanc ou noir et, à l'extérieur, dans différentes couleurs telles que le noyer clair, le noyer foncé et le carbone. Portes avec cadre en bois massif et double vitrage - réfrigération statique avec évaporateur à plaques d'aluminium positionné sur la paroi arrière - régulateur de température pour le contrôle automatique de la température - évaporation automatique de l'eau de condensation - éclairage LED contrôlé par interrupteur - ventilateur interne branché directement sur l'alimentation électrique pour uniformiser la température.

DE Displays mit statischer Kühlung mit äußerem Holzgehäuse, erhältlich mit weißem oder schwarzem Innenraum und außen in verschiedenen Farben wie hellem Nussbaum, dunklem Nussbaum und Carbon. Türen mit Massivholzrahmen und Doppelverglasung - statische Kühlung mit Aluminiumplatten-Verdampfer an der Rückwand - Temperaturregler für die automatische Temperaturkontrolle - automatische Kondenswasser-Verdunstung - LED-Beleuchtung über Schalter gesteuert - interner Gebläse, der direkt an die Stromversorgung angeschlossen ist, um die Temperatur gleichmäßig zu halten.

## OPTIONAL

GRP200 ●	GRP200B ●	GRP400 ●	GRP400B ●
colore bianco / white colour	colore nero / black colour	colore bianco / white colour	colore nero / black colour
505 x 215 mm		505 x 415 mm	
Griglia plastificata - Plastic coated grid - Grille plastifiée - Kunststoff Gitter			

# KL2791-KL2791N KL2791CA-KL2791B KL2791NB-KL2791CAB

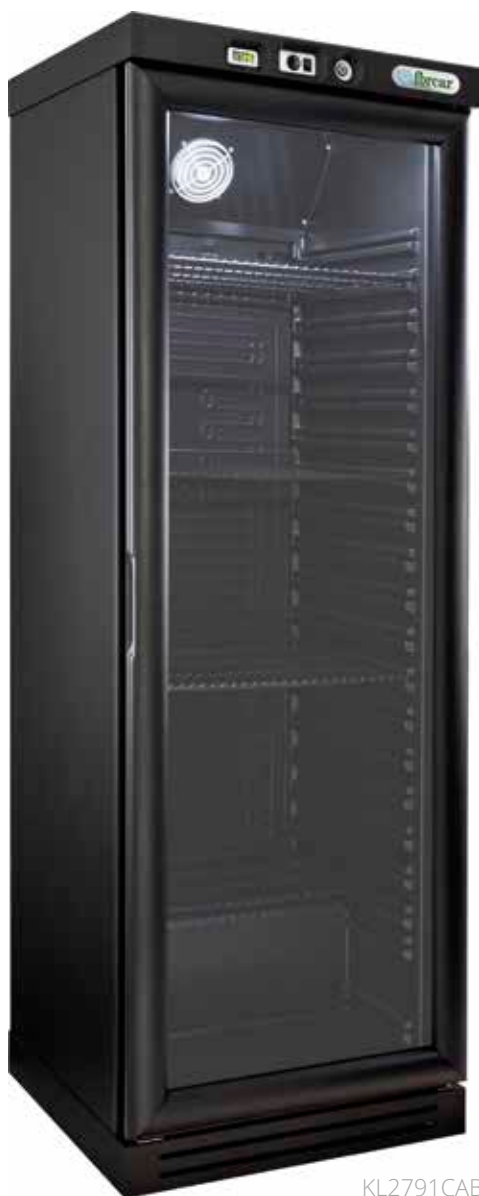

KL2791CAB

Specificare al momento dell'ordine il colore interno ed esterno scelto.  
Specify internal/external color  
ES: bianco/noce chiaro - White/light walnut

## ESTERNO EXTERNAL



NOCE SCURO  
DARK WALNUT



NOCE CHIARO  
LIGHT WALNUT



CARBON  
CHARCOAL GRAY

## INTERNO INTERNAL



BIANCO / WHITE



NERO / BLACK

	KL2791 - KL2791N KL2791CA interno bianco / internal white	KL2791B - KL2791NB KL2791CAB interno nero / internal black
	+2°C / +8°C	
	640 x 610 x 1860(h) mm	
	460 x 450 x 1500(h) mm	
	340 L	
	+32°C / 55%HR	
	evaporatore a piastra / plate evaporator	
<b>DEFROST</b>	automatico / automatic	
<b>GAS</b>	R600a	
	automatica / automatic	
	automatica / automatic	
	45 mm	
	185 W	
	230V / 50Hz	
<b>MATERIAL</b>	legno / wood - ABS	
<b>REVERSIBLE</b>	no	
	led	
<b>STANDARD</b>	3 griglie / grids 505 x 415 mm 1 griglia / grid 505 x 215 mm	
<b>ENERGY CLASS</b>		
	130 Kg	
	150 Kg	
	800 x 800 x 2280(h) mm	

# KL2791F-KL2791FN KL2791FCA-KL2791FB KL2791FNB-KL2791FCAB



KL2791F

Specificare al momento dell'ordine il colore interno ed esterno scelto.  
Specify internal/external color  
ES: nero/noce scuro - black/ dark walnut

## ESTERNO EXTERNAL



NOCE SCURO  
DARK WALNUT



NOCE CHIARO  
LIGHT WALNUT



CARBON  
CHARCOAL GRAY

## INTERNO INTERNAL



BIANCO / WHITE



NERO / BLACK

	KL2791F - KL2791FN KL2791FCA interno bianco / internal white	KL2791FB - KL2791FNB KL2791FCAB interno nero / internal black
	-18°C / -22°C	
	640 x 610 x 1860(h) mm	
	460 x 450 x 1500(h) mm	
	340 L	
	+32°C / 55%HR	
	evaporatore a piastra / plate evaporator	
<b>DEFROST</b>	automatico / automatic	
<b>GAS</b>	R600a	
	automatica / automatic	
	automatica / automatic	
	45 mm	
	380 W	
	230V / 50Hz	
<b>MATERIAL</b>	legno / wood - ABS	
<b>REVERSIBLE</b>	no	
	led	
<b>STANDARD</b>	6 ripiani fissi / fixed shelves 480 x 440 mm	
<b>ENERGY CLASS</b>		
	130 Kg	
	150 Kg	
	800 x 800 x 2280(h) mm	

## Glass Line

Cantinette vini refrigerate - statiche / Refrigerated wine cellars - statics  
Caves à vin réfrigérées - statiques / Gekühlte Weinkeller - statisch

# KL2792-KL2792N KL2792CA-KL2792B KL2792NB-KL2792CAB



KL2792

## ESTERNO EXTERNAL



NOCE SCURO  
DARK WALNUT



NOCE CHIARO  
LIGHT WALNUT



CARBON  
CHARCOAL GRAY

## INTERNO INTERNAL



BIANCO / WHITE



NERO / BLACK

	KL2792 - KL2792N KL2792CA interno bianco / internal white	KL2792B - KL2792NB KL2792CAB interno nero / internal black
	+2°C / +8°C +2°C / +8°C	
	1280 x 610 x 1860(h) mm	
	460 x 450 x 1500(h) mm 460 x 450 x 1500(h) mm	
	340 + 340 L	
	+32°C / 55%HR	
	evaporatore a piastra / plate evaporator	
<b>DEFROST</b>	automatico / automatic	
<b>GAS</b>	R600a	
	automatica / automatic	
	automatica / automatic	
	45 mm	
	185 + 185 W	
	230V / 50Hz	
<b>MATERIAL</b>	legno / wood - ABS	
	no	
	led	
<b>STANDARD</b>	6 griglie / grids 505 x 415 mm 2 griglie / grids 505 x 215 mm	
<b>ENERGY CLASS</b>		
	260 Kg	
	290 Kg	
	1430 x 800 x 2280(h) mm	

Specificare al momento dell'ordine il colore interno ed esterno scelto.  
Specify internal/external color  
ES: bianco/noce chiaro - White/light walnut

# KL2794-KL2794N KL2794CA-KL2794B KL2794NB-KL2794CAB



KL2794B

## ESTERNO EXTERNAL



NOCE SCURO  
DARK WALNUT



NOCE CHIARO  
LIGHT WALNUT



CARBON  
CHARCOAL GRAY

## INTERNO INTERNAL



BIANCO / WHITE



NERO / BLACK

Specificare al momento dell'ordine il colore interno ed esterno scelto.  
Specify internal/external color  
ES: nero/noce scuro - black/ dark walnut

	KL2794 - KL2794N KL2794CA interno bianco / internal white	KL2794B - KL2794NB KL2794CAB interno nero / internal black
	+2°C / + 8°C -18°C / -22°C	
	1280 x 610 x 1860(h) mm	
	460 x 450 x 1500(h) mm 460 x 450 x 1500(h) mm	
	340 + 340 L	
	+32°C / 55%HR	
	evaporatore a piastra / plate evaporator	
<b>DEFROST</b>	automatico / automatic	
<b>GAS</b>	R600a	
	automatica / automatic	
	automatica / automatic	
	45 mm	
	185 + 380 W	
	230V / 50Hz	
<b>MATERIAL</b>	legno / wood - ABS	
	no	
	led	
<b>STANDARD</b>	3 griglie / grids 505 x 415 mm - 1 griglia / grid 505 x 215 mm 6 ripiani fissi / fixed shelves 480 x 440 mm	
	260 Kg	
	290 Kg	
	1430 x 800 x 2280(h) mm	

## Glass Line

Cantinerie vini refrigerate - statiche / Refrigerated wine cellars - statics  
Caves à vin réfrigérées - statiques / Gekühlte Weinkeller - statisch

# KL2793-KL2793N KL2793CA-KL2793B KL2793NB-KL2793CAB



KL2793N

## ESTERNO EXTERNAL



NOCE SCURO  
DARK WALNUT



NOCE CHIARO  
LIGHT WALNUT



CARBON  
CHARCOAL GRAY

## INTERNO INTERNAL



BIANCO / WHITE



NERO / BLACK

	KL2793 - KL2793N KL2793CA interno bianco / internal white	KL2793B - KL2793NB KL2793CAB interno nero / internal black
	+2°C / +8°C	
	640 x 610 x 870(h) mm	
	510 x 485 x 620(h) mm	
	130 L	
	+32°C / 55%HR	
	evaporatore a piastra / plate evaporator	
<b>DEFROST</b>	automatico / automatic	
<b>GAS</b>	R600a	
	automatica / automatic	
	automatica / automatic	
	40 mm	
	105 W	
	230V / 50Hz	
<b>MATERIAL</b>	legno / wood - ABS	
	si / yes	
	led	
<b>STANDARD</b>	1 griglia / grid 505 x 415 mm 1 griglia / grid 505 x 215 mm	
<b>ENERGY CLASS</b>	<b>B</b>	
	44 Kg	
	60 Kg	
	680 x 650 x 1180(h) mm	

Specificare al momento dell'ordine il colore interno ed esterno scelto.  
Specify internal/external color  
ES: bianco/noce chiaro - White/light walnut



## Glass Line

Cantinette vini refrigerate - statiche / Refrigerated wine cellars - statics  
Caves à vin réfrigérées - statiques / Gekühlte Weinkeller - statisch

# Cantinette vini refrigerate - ventilate modello ENOLO - Glass Line



**IT** Cantinette per vini con refrigerazione ventilata - modello Enolo. Centralina e display digitali - struttura esterna verniciata nera - fianchi interni in ABS nero e pannello posteriore in acciaio inox AISI 304 - luce interna LED - doppio vetro temperato con protezione raggi UV - cornice porta in acciaio inox - chiusura porta con chiave. Modelli VI120D e VI180D con temperature differenziate. Il prezzo delle cantinette vini è comprensivo di griglie plastificate nere scorrevoli (vedi tabella dotazione standard), come optional è possibile ordinare griglie in legno scorrevoli.

**EN** Wine cellars with ventilated refrigeration - Enolo model. Digital control unit and display - black painted external casing - internal sides in black ABS and back panel in stainless steel AISI 304 - internal LED light - double tempered glass with UV protection - stainless steel door frame - door lock with key. Models VI120D and VI180D with differentiated temperatures. The price of wine cellars includes black plastic-coated sliding grids (see standard equipment table). Sliding wooden grids can be ordered as option.

**FR** Caves à vin avec réfrigération ventilée - modèle Enolo. Unité de commande et afficheur numériques - corps extérieur peint en noir - côtés intérieurs en ABS noir et panneau arrière en acier inox AISI 304 - éclairage interne à LED - double verre trempé avec protection UV - cadre de porte en acier inox - serrure de porte avec clé. Modèles VI120D et VI180D avec températures variables. Le prix des caves à vin comprend des grilles glissantes revêtues de plastique noir (voir tableau équipement standard). Des grilles glissantes en bois sont disponibles en option.

**DE** Weinkeller mit Umluftkühlung - Modell Enolo. Digitale Steuereinheit und Display - schwarz lackiertes Außengehäuse - Innenseiten aus schwarzem ABS und Rückwand aus Edelstahl AISI 304 - LED-Innenbeleuchtung - doppelt gehärtetes Glas mit UV-Schutz - Türrahmen aus Edelstahl - Türschloss mit Schlüssel. Modelle VI120D und VI180D mit unterschiedbare Temperaturen. Der Preis für die Weinkühlschränke beinhaltet schwarz kunststoffbeschichtete Schiebegitter (siehe Tabelle Standardausstattung). Optional können auch Schiebegitter aus Holz bestellt werden.

## OPTIONAL

DZ18S	DZ18W
<p>Griglia plastificata nera scorrevole + coppia guide Black plasticized sliding grid + pair of slides Grille coulissante plastifiée noire + paire de glissières Schwarzes plastifiziertes Gleitgitter + Paar Dias</p>	<p>Griglia in legno scorrevole + coppia guide Sliding wood grid + pair of slides Grille coulissante en bois + paire de glissières Gleitendes Holzgitter + Führungsschienen</p>
	

# G-VI120S G-VI120D



G-VI120S

- Max. 10 griglie/grids

G-VI120D

- Max. 9 griglie/grids



Packing list: 2 colli

	G-VI120S	G-VI120D
	+5°C / +18°C	+5°C / +12°C +12°C / +20°C
	595 x 710 x 1270(h) mm	
	490 x 551 x 1055(h) mm	
	270 L max. 71 bottiglie / bottles	261 L max. 65 bottiglie / bottles
	+32°C / 55%HR	
	ventilata / ventilated	
<b>DEFROST</b>	automatica / automatic	
<b>GAS</b>	R600a	
	automatico / automatic	
	controllo touchpad / touch pad controller	
	55 mm	
	160 W	
	230V / 50Hz	
<b>MATERIAL</b>	lamiera verniciata + ABS + acciaio Inox + vetro painted tin plate + ABS + stainless steel + glass	
<b>REVERSIBLE</b>	si / yes	
	led	
<b>STANDARD</b>	3 griglie plastificate nere scorrevoli + 3 coppia guide 3 black plasticized sliding grids + 3 pair of slides	
<b>ENERGY CLASS</b>		
	71 Kg	74 Kg
	82 Kg	85 Kg
	645 x 780 x 1420(h) mm	

# G-VI180S G-VI180D



G-VI180S  
- Max. 15 griglie/grids

G-VI180D  
- Max. 14 griglie/grids



## Glass Line

Cantinette vini refrigerate - ventilate - modello ENOLO / Refrigerated wine cellars - ventilated - ENOLO model  
Caves à vin réfrigérées - ventilées - Ligne ENOLO / Gekühlte Weinkeller - Umluftgekühlt - Modell ENOLO

	G-VI180S	G-VI180D
	+5°C / +18°C	+5°C / +12°C +12°C / +20°C
	595 x 710 x 1720(h) mm	
	490 x 551 x 1500(h) mm	
	388 L max. 101 bottiglie / bottles	379 L max. 95 bottiglie / bottles
	+32°C / 55%HR	
	ventilata / ventilated	
<b>DEFROST</b>	automatica / automatic	
<b>GAS</b>	R600a	
	automatico / automatic	
	controllo touchpad / touch pad controller	
	55 mm	
	160 W	
	230V / 50Hz	
<b>MATERIAL</b>	lamiera verniciata + ABS + acciaio Inox + vetro painted tin plate + ABS + stainless steel + glass	
	si / yes	
	led	
<b>STANDARD</b>	5 griglie plastificate nere scorrevoli + 5 coppia guide 5 black plasticized sliding grids + 5 pair of slides	
<b>ENERGY CLASS</b>		
	92 Kg	94 Kg
	103 Kg	106 Kg
	645 x 780 x 1870(h) mm	

Packing list: 2 colli



# Cantinette vini

## refrigerate - statiche - modello BJ - Glass Line



IT Cantinette per vini con refrigerazione statica. Centralina e display digitali - temperatura differenziata a seconda della posizione (da +5°C del ripiano inferiore a +18°C di quello superiore) - struttura esterna verniciata nera - interno alluminio nero goffato - luce interna LED - doppio vetro temperato con protezione raggi UV - chiusura a porta con chiave. Il prezzo delle cantinette vini è comprensivo di griglie in acciaio fisse (vedi tabella dotazione standard), come optional è possibile ordinare griglie in legno scorrevoli.

EN Wine cellars with static refrigeration. Digital control unit and display - temperature differentiated according to the position (from +5°C on the lower shelf to +18°C on the upper shelf) - black painted external structure - embossed black aluminium internal structure - internal LED light - double tempered glass with UV protection - door lock with key. The price of wine cellars includes fixed steel grids (see standard equipment table). Sliding wooden grids can be ordered as option.

FR Caves à vin avec réfrigération statique. Unité de commande et d'affichage numérique - température différenciée selon la position (de +5°C de l'étagère inférieure à +18°C de l'étagère supérieure) - corps extérieur peint en noir - profil intérieur en aluminium gaufré noir - éclairage intérieur à LED - double verre trempé avec protection UV - serrure avec clé. Le prix des caves à vin comprend des grilles fixes en acier (voir tableau équipement standard). Des grilles glissantes en bois sont disponibles en option.

DE Weinkeller mit statischer Kühlung. Digitales Steuergerät und Display - je nach Position unterschiedliche Temperatur (von +5°C des unteren Fachs bis +18°C des oberen Fachs) - schwarz lackiertes Außen-gehäuse - schwarz geprägte Innenstruktur aus Aluminium - LED-Innenbeleuchtung - doppelt gehärtetes Glas mit UV-Schutz - Türschloss mit Schlüssel. Der Preis für die Weinkühlschränke beinhaltet feste Stahlgitter (siehe Tabelle Standardausstattung). Optional können auch Schiebegeritter aus Holz bestellt werden.

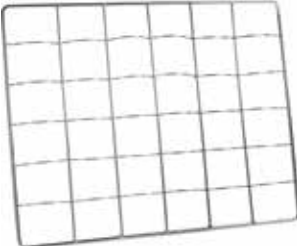
### OPTIONAL

BJ22S	BJ21W
Griglia in acciaio fissa + coppia guide Fixed steel grid + slides Grille fixe en acier + glissières Festes Stahlgitter + Führungsschienen	Griglia in legno scorrevole + coppia guide Sliding wood grid + pair of slides Grille coulissante en bois + paire de glissières Gleitendes Holzgitter + Führungsschienen
	

# G-BJ118 G-BJ208



G-BJ118  
- Max. 4 griglie/grids



G-BJ208  
- Max. 9 griglie/grids

	G-BJ118	G-BJ208
	+5°C / +18°C	
	600 x 603 x 860(h) mm	600 x 603 x 1260(h) mm
	520 x 470 x 695(h) mm	520 x 470 x 1095(h) mm
	24 bottiglie / bottles max 4 griglie / grills	54 bottiglie / bottles max 9 griglie / grills
	+33°C / 60%HR	
	statica / static	
<b>DEFROST</b>	automatico / automatic	
<b>GAS</b>	R600a	
	automatica / automatic	
	elettronico / electronic	
	40 mm	
	77 W	82 W
	230V / 50Hz	
<b>MATERIAL</b>	vernice nera + alluminio nero goffrato black coating + black embossed aluminium	
	no	
	led	
<b>STANDARD</b>	1 griglia in acciaio / stainless steel grid + 1 coppia guide / pair of slides	3 griglia in acciaio / stainless steel grids + 3 coppie guide / pair of slides
<b>ENERGY CLASS</b>		
	46 Kg	60 Kg
	66 Kg	83 Kg
	660 x 660 x 1140(h) mm	660 x 660 x 1540(h) mm

# G-BJ308 G-BJ408



G-BJ308

- Max. 12 griglie/grids

G-BJ408

- Max. 16 griglie/grids

	G-BJ308	G-BJ408
	+5°C / +18°C	
	600 x 603 x 1560(h) mm	600 x 603 x 1860(h) mm
	520 x 470 x 1395(h) mm	520 x 470 x 1695(h) mm
	72 bottiglie / bottles max 12 griglie / grills	96 bottiglie / bottles max 16 griglie / grills
	+33°C / 60%HR	
	statica / static	
<b>DEFROST</b>	automatico / automatic	
<b>GAS</b>	R600a	
	automatica / automatic	
<b>CONTROL</b>	elettronico / electronic	
	40 mm	
	100 W	112 W
	230V / 50Hz	
<b>MATERIAL</b>	vernice nera + alluminio nero goffrato black coating + black embossed aluminium	
<b>REVERSIBLE</b>	no	
	led	
<b>STANDARD</b>	4 griglie in acciaio / stainless steel grids + 4 coppie guide / pair of slides	5 griglie in acciaio / stainless steel grids + 5 coppie guide / pair of slides
<b>ENERGY CLASS</b>		
<b>NET</b> Kg	72 Kg	85 Kg
<b>GROSS</b> Kg	99 Kg	110 Kg
	660 x 660 x 1840(h) mm	660 x 660 x 2140(h) mm



Packing list: 2 colli

## Glass Line

Cantinette vini refrigerate- statica - modello BJ / Refrigerated wine cellars - static - model BJ  
Cave à vins réfrigérées - statiques - modél BJ / Gekühlte Weinkeller - statisch - Modell BJ

# Armadi refrigerati

## linea snack - ventilati - Glass Line

IT Armadi refrigerati linea snack con refrigerazione ventilata.  
Struttura esterna e interna in lamiera verniciata epossidica - chiusura porta con molla di ritorno - porta in doppio vetro con resistenza anti condensa - luce interna a LED - pannelli esterni di fondo e retro in lamiera zincata.

EN Snack line refrigerated cabinets with ventilated refrigeration.  
External and internal casings in epoxy-coated plate - door closure with self closing spring - double-glazed door with anti-condensation resistance - internal LED light - external back and bottom panels in galvanised plate.

FR Armoires réfrigérées de la ligne Snack avec réfrigération ventilée. Corps extérieur et intérieur en tôle époxy - fermeture de la porte avec ressort de rappel - porte à double vitrage avec résistance anti-condensation - éclairage intérieur à LED - panneaux extérieurs arrière et de fond en tôle galvanisée.

DE Snack-Serie-Kühlschränke mit Umluftkühlung.  
Äußeres Gehäuse und Innenstruktur aus epoxidbeschichtetem Blech - Türverschluss mit Rückholfeder - doppelt verglaste Tür Heizstab zur Kondensatwasserverdampfung - LED-Innenbeleuchtung - äußere Rückwand und Boden aus verzinktem Blech.

### OPTIONAL

GRP610B	GRP1200B	GRP420	GRP930	AG	AG1
G-SNACK610BTG	G-SNACK1220BTG	G-SNACK420BTG	G-SNACK930BTG		G-SNACK610BTG G-SNACK1220BTG
461 x 490 mm	490 x 490 mm	545 x 485 mm	615 x 445 mm		
Griglia plastificata - Plastic-coated grid - Grille plastifiée - Kunststoff Gitter				Set aggancio per griglie Clamping set for grids Jeu de serrage pour grilles Klemmset für Gitterroste	

# G-SNACK610BTG G-SNACK1220BTG



G-SNACK1220BTG

G-SNACK610BTG

	G-SNACK610BTG	G-SNACK1220BTG
	-18°C / -22°C	
	610 x 765 x 1893(h) mm	1220 x 765 x 1893(h) mm
	493 x 558 x 1394(h) mm	1103 x 558 x 1394(h) mm
	332 L	744 L
	+32°C / 55%HR	
	ventilata / ventilated	
<b>DEFROST</b>	automatico / automatic	
<b>GAS</b>	R290	
	automatica / automatic	
<b>CONTROL</b>	elettronico / electronic	
	60 mm	
	690 W	1100 W
	230V / 50Hz	
<b>MATERIAL</b>	lamiera verniciata nera + alluminio black painted tin plate + aluminum	
<b>REVERSIBLE</b>	no	
	si / yes	
<b>STANDARD</b>	5 griglie / grids 461 x 490 mm	10 griglie / grids 490 x 490 mm
<b>ENERGY CLASS</b>	<b>E</b>	<b>F</b>
<b>NET Kg</b>	122 Kg	194 Kg
<b>GROSS Kg</b>	141 Kg	236 Kg
	660 x 815 x 2010(h) mm	1270 x 815 x 2010(h) mm





















## Glass Line

Armadi refrigerati linea snack - ventilati / Snack Refrigerated cabinets - ventilated  
Armoires réfrigérées ligne snack - ventilées / Kühlschränke - Umluftkühlung - Snack-Linie



















# G-SNACK420BTG



	G-SNACK420BTG
	-18°C / -22°C
	680 x 700 x 2000(h) mm
	564 x 570 x 1310(h) mm
	578 L
	+32°C / 55%HR
	ventilata / ventilated
<b>DEFROST</b>	automatico / automatic
<b>GAS</b>	R290
	automatica / automatic
	elettronico / electronic
<b>CONTROL</b>	60 mm
	850 W
	230V / 50Hz
<b>MATERIAL</b>	lamiera verniciata / painted tin plate + porta in vetro / glass door
	no
	si / yes
<b>STANDARD</b>	4 griglie / grids 545 x 485 mm
<b>ENERGY CLASS</b>	
	
	138 Kg
	167 Kg
	715 x 765 x 2290(h) mm

# G-SNACK930BTG



	G-SNACK930BTG
	-18°C / -22°C
	1370 x 700 x 2000(h) mm
	1250 x 570 x 1310(h) mm
	1078 L
	+32°C / 55%HR
	ventilata / ventilated
<b>DEFROST</b>	automatico / automatic
<b>GAS</b>	R290
	automatica / automatic
	elettronico / electronic
	60 mm
	1000 W
	230V / 50Hz
<b>MATERIAL</b>	lamiera verniciata / painted tin plate + porta in vetro / glass door
	no
	si / yes
<b>STANDARD</b>	8 griglie / grids 615 x 445 mm
<b>ENERGY CLASS</b>	
	
	212 Kg
	260 Kg
	1405 x 765 x 2290(h) mm



## Glass Line

Armadi refrigerati linea snack - ventilati / Snack Refrigerated cabinets - ventilated  
Armoires réfrigérées ligne snack - ventilées / Kühlschränke - Umluftkühlung - Snack-Linie

# Armadi refrigerati

## linea snack - statici - Glass Line

IT Armadi refrigerati linea snack con refrigerazione statica.  
Struttura esterna in lamiera verniciata epossidica nera - interno in alluminio verniciato epossidico nero (interno in ABS per i modelli 176-251) - luce interna - pannelli esterni di fondo e retro in lamiera zincata - termometro digitale. Guarnizioni porta estraibili.

EN Snack line refrigerated cabinets with static refrigeration.  
External casing in black epoxy-coated plate - interior in black epoxy-coated aluminium (ABS interior for models 176-251) - internal light - external back and bottom panels in galvanised plate - digital thermometer. Removable door gaskets.

FR Armoires réfrigérées de la ligne Snack avec réfrigération statique.  
Corps extérieur en tôle époxy noir - intérieur en aluminium époxy noir (intérieur en ABS pour les modèles 176-251) - éclairage intérieur - panneaux extérieurs arrière et de fond en tôle galvanisée - thermomètre digital. Joints de porte amovibles.

DE Snack-Serien-Kühlschränke mit statischer Kühlung.  
Äußeres Gehäuse aus Schwarz, epoxidbeschichtetem Blech - Innenraum aus Schwarz, epoxidbeschichtetem Aluminium (ABS-Innenraum für die Modelle 176-251) - Innenbeleuchtung - äußere Rückwand und Boden aus verzinktem Blech - digitales Thermometer. Abnehmbare Türdichtungen.

## OPTIONAL

GRP160H	GRP176A	GRP251A	GRP290N	GRP34	GRP638SX	GRP638DX
G-SNACKBC160H	G-SNACK176SC	G-SNACK251SC	G-SNACK290SC	G-SNACK340TNG	G-SNACK638L2TNG Sinistra - Left	G-SNACK638L2TNG Destra - Right
328 x 278 mm	470 x 275 mm	460 x 310 mm	490 x 330 mm	525 x 335 mm	540 x 350 mm	
Griglia plastificata - Plastic-coated grid - Grille plastifiée - Kunststoff Gitter						

GRP50G	GRP100G	AG	AG2
G-SC50G	G-SC100G		G-SNACKBC160H
470 x 400 mm	530 x 395 mm		
Griglia plastificata - Plastic-coated grid - Grille plastifiée - Kunststoff Gitter		Set aggancio per griglie - Clamping set for grids Jeu de serrage pour grilles - Klemmsset für Gitterroste	

# G-SNACKBC160H



Guarnizioni porta estraibili  
Removable door gaskets

	G-SNACKBC160H
	0°C / +10°C
	390 x 480 x 1888(h) mm
	300 x 360 x 1505(h) mm
	162 L
	+30°C / 55%HR
	statica / static
<b>DEFROST</b>	automatico / automatic
<b>GAS</b>	R600a
	automatica / automatic
	elettronico / electronic
<b>CONTROL</b>	45 mm
	140 W
	230V / 50Hz
<b>MATERIAL</b>	lamiera verniciata nera / painted tin plate black + porta in vetro / glass door
<b>REVERSIBLE</b>	no
	si / yes
<b>STANDARD</b>	5 piani / shelves - 5 griglie / grids 328 x 278 mm
<b>ENERGY CLASS</b>	<b>B</b>
	60 Kg
	63 Kg
	448 x 515 x 2003(h) mm



## Glass Line

Armadi refrigerati linea snack - statici / Snack Refrigerated cabinets - statics  
Armoires réfrigérées ligne snack - statiques / Kühlschränke - Umluftkühlung - Snack-Linie

# G-SNACK176SC G-SNACK251SC



G-SNACK176SC

G-SNACK251SC

	G-SNACK176SC	G-SNACK251SC
	+2°C / +8°C	
	550 x 450 x 1650(h) mm	550 x 538 x 1880(h) mm
	470 x 290 x 950(h) mm	460 x 350 x 1170(h) mm
	171 L	244 L
	+32°C / 55%HR	
	statica / static	
<b>DEFROST</b>	automatico / automatic	
<b>GAS</b>	R600a	
	automatica / automatic	
	termostato / thermostat	
<b>CONTROL</b>		
	35 mm	40 mm
	90 W	165 W
	230V / 50Hz	
<b>MATERIAL</b>	lamiera verniciata / painted tin plate + ABS	
<b>REVERSIBLE</b>	no	
	si / yes	
<b>STANDARD</b>	4 griglie / grids 470 x 275 mm	4 griglie / grids 460 x 310 mm
<b>ENERGY CLASS</b>		
	53 Kg	73 Kg
	68 Kg	88 Kg
	626 x 537 x 1870(h) mm	626 x 603 x 2020(h) mm

# G-SNACK290SC G-SNACK340TNG



G-SNACK290SC

G-SNACK340TNG





















## Glass Line

Armadi refrigerati linea snack - statici / Snack Refrigerated cabinets - statics  
Armoires réfrigérées ligne snack - statiques / Kühlschränke - Umluftkühlung - Snack-Linie

	G-SNACK290SC	G-SNACK340TNG
	+2°C / +8°C	
	595 x 575 x 1910(h) mm	660 x 650 x 1910(h) mm
	500 x 400 x 1200(h) mm	570 x 550 x 1260(h) mm
	290 L	331 L
	+32°C / 55%HR	
	statica / static	
<b>DEFROST</b>	automatico / automatic	
<b>GAS</b>	R600a	
	automatica / automatic	
	termostato / thermostat	
<b>CONTROL</b>	40 mm	45 mm
	165 W	
	230V / 50Hz	
<b>MATERIAL</b>	lamiera verniciata / painted tin plate	
	no	
	si / yes	
<b>STANDARD</b>	4 griglie / grids 490 x 330 mm	4 griglie / grids 525 x 335 mm
<b>ENERGY CLASS</b>		
	100 Kg	95 Kg
	116 Kg	111 Kg
	688 x 641 x 2050(h) mm	720 x 690 x 2210(h) mm

# G-SNACK638L2TNG



	G-SNACK638L2TNG
	+2°C / +8°C
	1198 x 530 x 1880(h) mm
	1110 x 360 x 1250(h) mm
	620 L
	+32°C / 55%HR
	statica / static
<b>DEFROST</b>	automatico / automatic
<b>GAS</b>	R600a
	automatica / automatic
	elettronico / electronic
<b>CONTROL</b>	45 mm
	250 W
	230V / 50Hz
<b>1 Ph</b>	
<b>MATERIAL</b>	lamiera verniciata / painted tin plate
	no
<b>REVERSIBLE</b>	si / yes
	
<b>STANDARD</b>	8 griglie / grids 540 x 350 mm
<b>ENERGY CLASS</b>	
	
	130 Kg
	148 Kg
	1270 x 610 x 2180(h) mm

## G-SC50G



Espositori ideali per prodotti da prima colazione  
(come latte, yogurt ed eventuali prodotti refrigerati)  
Ideal for breakfast products (milk, yogurt or refrigerated products)

## G-SC100G



### Glass Line

Armadi refrigerati linea snack - statici / Snack Refrigerated cabinets - statics  
Armoires réfrigérées ligne snack - statiques / Kühlschränke - Umluftkühlung - Snack-Linie

	G-SC50G	G-SC100G
	+2°C / +8°C	
	570 x 533 x 540(h) mm	620 x 543 x 700(h) mm
	490 x 440 x 420(h) mm	540 x 450 x 580(h) mm
	68 L	115 L
	+32°C / 55%HR	
	evaporatore a piastra / plate evaporator	
<b>DEFROST</b>	automatico / automatic	
<b>GAS</b>	R600a	
	evaporatore a piastra / plate evaporator	
	termostato / thermostat	
<b>CONTROL</b>		
	40 mm	
	85 W	
	230V / 50Hz	
	1 Ph	
<b>MATERIAL</b>	lamiera verniciata / painted tin plate + vetrocamera / insulating glass	
	no	
	led	
<b>STANDARD</b>	1 griglia / grid 470 x 400 mm 1 griglia / grid 470 x 200 mm	1 griglia / grid 530 x 395 mm 1 griglia / grid 530 x 240 mm
<b>ENERGY CLASS</b>		
	40 Kg	46 Kg
	50 Kg	57 Kg
	645 x 620 x 675(h) mm	695 x 630 x 835(h) mm

# Bottle Cooler

## statici - ventilati - Glass Line

IT Bottle Cooler con refrigerazione ventilata o statica. Espositori refrigerati verticali o orizzontali per bibite - materiale esterno verniciato nero - interno in alluminio - sbrinamento automatico - termostato di regolazione temperatura elettronico - porta scorrevole per i codici PS - porta a battente per i codici PB.

EN Bottle Cooler with ventilated or static refrigeration. Vertical or horizontal refrigerated beverage displays - black painted exterior material - aluminium interior - automatic defrosting - electronic temperature control thermostat - sliding door for PS codes - hinged door for PB codes.

FR Refroidisseur de bouteilles avec réfrigération ventilée ou statique. Présentoirs réfrigérés verticaux ou horizontaux pour boissons - matériau extérieur peint en noir - intérieur en aluminium - dégivrage automatique - thermostat électronique de contrôle de la température - porte coulissante pour les codes PS - porte à charnières pour les codes PB.

DE Flaschenkühler mit Umluftkühlung oder statischer Kühlung. Vertikale oder horizontale Kühltheke für Getränke - schwarz lackiertes Außenmaterial - Innenraum aus Aluminium - automatische Abtauung - elektronischer Temperaturregelungsthermostat - Schiebetür für PS-Codes - Flügeltür für PB-Codes.

## OPTIONAL

GRPBC300	GRPBC500	GRPBC500L	GRPBC500R	AG
G-BC300BPB	G-BC500BPB	G-BC500BPS Sinistra - Left	G-BC500BPB Destra - Right	
515 x 337 x 40 mm	420 x 337 x 40 mm	400 x 352 x 40 mm	400 x 352 x 40 mm	
Griglia plastificata - Plastic-coated grid - Grille plastifiée - Kunststoff Gitter				Set aggancio per griglie - Clamping set for grids Jeu de serrage pour grilles - Klemmset für Gitterroste

GRCBC1	GRCBC2	GRCBC3C	GRCBC3L	GRP200B	GRP400B
G-BC1PB - G-BC1PB87	G-BC2PS - G-BC2PS87	G-BC3PS - G-BC3PS87 centrale / central	G-BC3PS - G-BC3PS87 laterale / lateral	G-ER200GB colore nero / black colour	G-ER400GB - G-EF400GB colore nero / black colour
520 x 315 mm	420 x 320 mm	445 x 320 mm	405 x 320 mm	505 x 215 mm	505 x 415 mm
Griglia plastificata - Plastic-coated grid - Grille plastifiée - Kunststoff Gitter					

G-BC300BPB  
G-BC500BPB  
G-BC500BPS



G-BC500BPB



G-BC300BPB

	G-BC300BPB	G-BC500BPB	G-BC500BPS
	+2°C / +8°C		
	600 x 514 x 1880(h) mm	920 x 514 x 1880(h) mm	
	535 x 424 x 1437(h) mm	855 x 424 x 1437(h) mm	
	193 L	315 L	
	+32°C / 55%HR		
	statica / static		
<b>DEFROST</b>	manuale / manual		
<b>GAS</b>	R600a		
	automatico / automatic		
	elettronico / electronic		
	35 mm		
	170 W	250 W	
	230V / 50Hz		
<b>MATERIAL</b>	lamiera verniciata nera / black painted tin plate + alluminio / alluminium		
	a battente / swing door	porte scorrevoli sliding doors	
	si / yes		
<b>STANDARD</b>	4 piani / shelves 515 x 337 mm	8 piani / shelves 420 x 337 mm	8 piani / shelves (4L-4R) 400 x 352 mm
<b>ENERGY CLASS</b>			
	98 Kg	125 Kg	128 Kg
	114 Kg	139 Kg	142 Kg
	655 x 570 x 2025(h) mm	975 x 570 x 2025(h) mm	



Glass Line

Bottle Cooler - statica / Bottle Cooler - static  
Refrroidisseur de bouteille - statiques / Flaschenkühler - statisch

# G-ER200GB

New



G-ER200GB

	G-ER200GB
	+2°C / +8°C
	600 x 585 x 855(h) mm
	510 x 485 x 620(h) mm
	130 L
	+32°C / 55%HR
	evaporatore a piastra / plate evaporator
DEFROST	automatico / automatic
GAS	R600a
	automatica / automatic
CONTROL	elettronico / electronic
	40 mm
	105 W
	230V / 50Hz
MATERIAL	lamiera verniciata nera / black painted tin plate ABS + vetrocamera / insulating glass
REVERSIBLE	si / yes
	led
STANDARD	2 griglie / grids 505 x 415 mm + 1 griglia / grid 505 x 215 mm
ENERGY CLASS	<b>B</b>
	44 Kg
	56 Kg
	680 x 650 x 1160(h) mm

ESTERNO  
EXTERNAL



NERO / BLACK

INTERNO  
INTERNAL



NERO / BLACK

# G-ER400GB G-EF400GB

New



G-ER400GB



G-EF400GB

ESTERNO  
EXTERNAL



NERO / BLACK

INTERNO  
INTERNAL



NERO / BLACK

	G-ER400GB	G-EF400GB
	+2°C / +8°C	-18°C / -22°C
	600 x 585 x 1855(h) mm	
	510 x 485 x 1620(h) mm	
	340 L	
	+32°C / 55%HR	
	evaporatore a piastra plate evaporator	evaporatore a ripiani shelves evaporator
DEFROST	automatico / automatic	manuale / manual
GAS	R600a	R290
	automatico / automatic	manuale / manual
CONTROL	elettronico / electronic	
	45 mm	60 mm
	185 W	380 W
	230V / 50Hz	
MATERIAL	lamiera verniciata nera / black painted tin plate ABS + vetrocamera / insulating glass	
REVERSIBLE	si / yes	no
	led	
STANDARD	3 griglie / grids 505 x 415 mm + 1 griglia / grid 505 x 215 mm	6 ripiani fissi / fixed shelves 480 x 440 mm
ENERGY CLASS	<b>B</b>	<b>C</b>
	69 Kg	76 Kg
	81 Kg	102 Kg
	680 x 650 x 2210(h) mm	

**forcar**  
by fimar REFRIGERATION

## Glass Line

Bottle Cooler - ventilata / Bottle Cooler - ventilated  
Refridisseur de bouteille - ventilé / Flaschenkühler - Umluftkühlung

# G-BC1PB - G-BC2PS G-BC3PS

920 mm



G-BC1PB



G-BC2PS

920 mm



G-BC3PS

920 mm

	G-BC1PB	G-BC2PS	G-BC3PS
	+2°C / +8°C		
	602 x 535 x 920(h) mm	920 x 535 x 920(h) mm	1350 x 535 x 920(h) mm
	537 x 408 x 765(h) mm	855 x 408 x 765(h) mm	1285 x 408 x 765(h) mm
	140 L	223 L	335 L
	+32°C / 55%HR		
	ventilata / ventilated		
<b>DEFROST</b>	automatico / automatic		
<b>GAS</b>	R600a		
	automatico / automatic		
<b>CONTROL</b>	elettronico / electronic		
	35 mm	40 mm	
	106 W	112 W	138 W
	230V / 50Hz		
<b>MATERIAL</b>	lamiera verniciata + alluminio painted tin plate + aluminium		
	a battente / swing door	porte scorrevoli / sliding doors	
	si / yes		
<b>STANDARD</b>	2 griglie / grids 520 x 315 mm	4 griglie / grids 420 x 320 mm	2 griglie / grids 445 x 320 mm 4 griglie / grids 405 x 320 mm
<b>ENERGY CLASS</b>			
	54 Kg	72 Kg	91 Kg
	75 Kg	96 Kg	118 Kg
	657 x 570 x 1200(h) mm	980 x 570 x 1200(h) mm	1405 x 570 x 1200(h) mm

# G-BC1PB87 - G-BC2PS87 G-BC3PS87



G-BC1PB87

G-BC2PS87



G-BC3PS87

	G-BC1PB87	G-BC2PS87	G-BC3PS87
	+2°C / +8°C		
	600 x 535 x 870(h) mm	900 x 535 x 870(h) mm	1350 x 535 x 870(h) mm
	535 x 370 x 735(h) mm	835 x 370 x 735(h) mm	1285 x 370 x 735(h) mm
	129 L	202 L	320 L
	+32°C / 55%HR		
	ventilata / ventilated		
<b>DEFROST</b>	automatico / automatic		
<b>GAS</b>	R600a		
	automatico / automatic		
<b>CONTROL</b>	elettronico / electronic		
	35 mm	40 mm	
	106 W	112 W	138 W
	230V / 50Hz		
<b>MATERIAL</b>	lamiera verniciata / painted tin plate + alluminio / aluminium		
<b>DOOR</b>	a battente / swing door	porte scorrevoli / sliding doors	
	si / yes		
<b>STANDARD</b>	2 griglie / grids 520 x 315 mm	4 griglie / grids 420 x 320 mm	2 griglie / grids 445 x 320 mm 4 griglie / grids 405 x 320 mm
<b>ENERGY CLASS</b>	<b>B</b>		<b>C</b>
	54 Kg	72 Kg	91 Kg
	75 Kg	96 Kg	118 Kg
	657 x 570 x 1200(h) mm	980 x 570 x 1200(h) mm	1405 x 570 x 1200(h) mm

## Glass Line

Bottle Cooler - ventilata / Bottle Cooler - ventilated  
Refridisseur de bouteille - ventilé / Flaschenkühler - Umluftkühlung

# Retro banchi bar ventilati

IT Retro banchi bar - refrigerazione ventilata - sbrinamento automatico - led - isolamento termico da 40 mm - struttura esterna in acciaio verniciato nero - interno in alluminio - disponibili con due o tre porte battenti - serratura su ogni porta.

EN Bar counter backs - ventilated refrigeration - automatic defrosting - LED lighting - 40 mm thermal insulation - black painted steel exterior - aluminium interior - available with two or three hinged doors - lock on each door.

FR Comptoirs de bar - réfrigération ventilée, dégivrage automatique, éclairage LED, isolation thermique de 40 mm, extérieur en acier peint en noir, intérieur en aluminium, disponibles avec deux ou trois portes battantes, serrure sur chaque porte.

DE Retro-Theken - Umluftkühlung - automatische Abtauung - LED-Leuchte - 40 mm Wärmedämmung - Gehäuse aus schwarz lackiertem Stahl - Innenraum aus Aluminium - mit zwei oder drei Flügeltüren erhältlich - Schloss an jeder Tür.



CGDC

Coppia guide - Pair of slides - Paire de glissières - Paar Führungen

GRIDC

Ripiano in acciaio forato - Perforated steel shelf - Étagère en acier perforé - Lochblechregal

# G-DC210 G-DC310

**New**



G-DC210



G-DC310



	G-DC210	G-DC310
	+2°C / +8°C	
	1465 x 520 x 840(h) mm	2005 x 520 x 840(h) mm
	1385 x 408 x 730(h) mm	1925 x 408 x 730(h) mm
	280 L	425 L
	+32°C / 55%HR	
	ventilata / ventilated	
<b>DEFROST</b>	automatico / automatic	
<b>GAS</b>	R290	
	automatico / automatic	
<b>CONTROL</b>	elettronico / electronic	
	40 mm	
	310 W	390 W
	230V / 50Hz	
<b>MATERIAL</b>	lamiera verniciata + alluminio painted tin plate + aluminium	
<b>DOOR</b>	2	3
	si / yes	
<b>STANDARD</b>	4 ripiani in acciaio forato perforated steel shelf	6 ripiani in acciaio forato perforated steel shelf
<b>ENERGY CLASS</b>	<b>D</b>	<b>E</b>
<b>NET Kg</b>	80 Kg	92 Kg
<b>GROSS Kg</b>	99 Kg	117 Kg
	1530 x 580 x 1035(h) mm	2070 x 580 x 1035(h) mm

# Carrelli portateglie

## GN1/1 - GN2/1 - ventilati - armadiati

IT Carrelli portateglie GN1/1 e GN2/1 refrigerati. Struttura ed interno in acciaio inox AISI 304 - maniglie laterali per conduzione carrello - porte reversibili - isolamento 60 mm - refrigerazione ventilata - ruote multidirezionali ø 125 mm di cui due con freno.

EN GN1/1 and GN2/1 refrigerated trolleys. AISI 304 stainless steel frame and interior - side handles for trolley guidance - reversible doors - 60 mm insulation - ventilated refrigeration - multidirectional wheels ø 125 mm, two of which with brake.

FR Chariots réfrigérés GN1/1 et GN2/1. Corps et intérieur en acier inox AISI 304 - poignées latérales pour le guidage du chariot - portes réversibles - isolation de 60 mm - réfrigération ventilée - roues pivotantes ø 125 mm, dont deux avec frein.

DE Gekühlte Servierwagen GN1/1 und GN2/1. Rahmen und Innenraum aus Edelstahl AISI 304 - seitliche Griffe für die Wagenführung - umkehrbare Türen - 60 mm Isolierung - belüftete Kühlung - Mehrzweckräder ø 125 mm, davon zwei mit Bremse.

G-HR290  
G-HR540



G-HR540

	G-HR290	G-HR540
	-2°C / +8°C	
	830 x 672 x 2030(h) mm	950 x 877 x 2030(h) mm
	650 x 395 x 1430(h) mm	770 x 600 x 1430(h) mm
	290 L - GN1/1 - 20 pcs	540 L - GN2/1 - 20 pcs
	+40°C / 55%HR	
	ventilata / ventilated	
DEFROST	automatico / automatic	
GAS	R600a	
	automatico / automatic	
	elettronico / electronic	
	60 mm	
	220 W	260 W
	230V/1N/50Hz	
MATERIAL	acciaio inox / stainless steel AISI 304	
	si / yes	
	no	
ENERGY CLASS		

PAG. 105 ON MULTISERVICE CATALOGUE









**Fimar S.p.a.**

Via Del Tesoro, 301

47826 Villa Verucchio (Rimini) Italy

t. +39 0541 670736

info@fimargroup.it

**FIMARGROUP.IT**  
**FIMARSPA.IT**  
**EASYLINEBYFIMAR.IT**  
**FORCAR.IT**  
**FORCOLD.IT**